Plastics — Epoxy resins —

Part 2:

**Preparation of test specimens
and determination of properties of
crosslinked epoxy resins**

Plastiques — Résines époxydes —

*Partie 2: Préparation des éprouvettes et détermination des propriétés
des résines époxydes réticulées*



Reference number
ISO 3673-2:2012(E)

© ISO 2012



COPYRIGHT PROTECTED DOCUMENT

© ISO 2012

All rights reserved. Unless otherwise specified, no part of this publication may be reproduced or utilized in any form or by any means, electronic or mechanical, including photocopying and microfilm, without permission in writing from either ISO at the address below or ISO's member body in the country of the requester.

ISO copyright office
Case postale 56 • CH-1211 Geneva 20
Tel. + 41 22 749 01 11
Fax + 41 22 749 09 47
E-mail copyright@iso.org
Web www.iso.org

Published in Switzerland

Contents

Page

Foreword	iv
1 Scope	1
2 Normative references	1
3 Preparation of test specimens	2
3.1 General	2
3.2 Pretreatment of materials	2
3.3 Preparation of test sheets	2
3.4 Cutting out test specimens	4
3.5 Conditioning test specimens	4
4 Determination of properties	4
Bibliography	6

Foreword

ISO (the International Organization for Standardization) is a worldwide federation of national standards bodies (ISO member bodies). The work of preparing International Standards is normally carried out through ISO technical committees. Each member body interested in a subject for which a technical committee has been established has the right to be represented on that committee. International organizations, governmental and non-governmental, in liaison with ISO, also take part in the work. ISO collaborates closely with the International Electrotechnical Commission (IEC) on all matters of electrotechnical standardization.

International Standards are drafted in accordance with the rules given in the ISO/IEC Directives, Part 2.

The main task of technical committees is to prepare International Standards. Draft International Standards adopted by the technical committees are circulated to the member bodies for voting. Publication as an International Standard requires approval by at least 75 % of the member bodies casting a vote.

Attention is drawn to the possibility that some of the elements of this document may be the subject of patent rights. ISO shall not be held responsible for identifying any or all such patent rights.

ISO 3673-2 was prepared by Technical Committee ISO/TC 61, *Plastics*, Subcommittee SC 12, *Thermosetting materials*.

This third edition cancels and replaces the second edition (ISO 3673-2:2007), which has been revised to make it clear that it applies only to crosslinked epoxy resins.

ISO 3673 consists of the following parts, under the general title *Plastics — Epoxy resins*:

- *Part 1: Designation*
- *Part 2: Preparation of test specimens and determination of properties of crosslinked epoxy resins*

Plastics — Epoxy resins —

Part 2:

Preparation of test specimens and determination of properties of crosslinked epoxy resins

SAFETY STATEMENT — Persons using this document should be familiar with normal laboratory practice, if applicable. This document does not purport to address all of the safety concerns, if any, associated with its use. It is the responsibility of the user to establish appropriate safety and health practices and to ensure compliance with any regulatory requirements.

1 Scope

This part of ISO 3673 specifies the methods of preparation of test specimens and the test methods to be used in determining the properties of crosslinked epoxy resins. The properties determined have been selected from the general test methods in ISO 10350-1:2007.

Test methods for the determination of the properties of non-crosslinked epoxy resins are not included in this part of ISO 3673.

NOTE Test methods for non-crosslinked epoxy resins are specified in ISO 18280.

In order to obtain reproducible and comparable test results, it is necessary to use the test methods, sample preparation and conditioning, and specimen dimensions specified herein. Values determined will not necessarily be identical to those obtained using test specimens of different dimensions or prepared using different procedures.

Other standards exist concerning the determination of properties and preparation of test specimens for epoxy-based products, to which reference will be made, if required.

2 Normative references

The following referenced documents are indispensable for the application of this document. For dated references, only the edition cited applies. For undated references, the latest edition of the referenced document (including any amendments) applies.

ISO 62, *Plastics — Determination of water absorption*

ISO 75-2, *Plastics — Determination of temperature of deflection under load — Part 2: Plastics and ebonite*

ISO 178, *Plastics — Determination of flexural properties*

ISO 179-1, *Plastics — Determination of Charpy impact properties — Part 1: Non-instrumented impact test*

ISO 179-2, *Plastics — Determination of Charpy impact properties — Part 2: Instrumented impact test*

ISO 527-2, *Plastics — Determination of tensile properties — Part 2: Test conditions for moulding and extrusion plastics*

ISO 2577, *Plastics — Thermosetting moulding materials — Determination of shrinkage*

ISO 2818, *Plastics — Preparation of test specimens by machining*

ISO 3167, *Plastics — Multipurpose test specimens*

ISO 4589-2, *Plastics — Determination of burning behaviour by oxygen index — Part 2: Ambient-temperature test*

ISO 10350-1:2007, *Plastics — Acquisition and presentation of comparable single-point data — Part 1: Moulding materials*

ISO 11357-2, *Plastics — Differential scanning calorimetry (DSC) — Part 2: Determination of glass transition temperature*

ISO 11359-2, *Plastics — Thermomechanical analysis (TMA) — Part 2: Determination of coefficient of linear thermal expansion and glass transition temperature*

IEC 60093, *Methods of test for volume resistivity and surface resistivity of solid electrical insulating materials*

IEC 60112, *Method for the determination of the proof and the comparative tracking indices of solid insulating materials*

IEC 60243-1, *Electrical strength of insulating materials — Test methods — Part 1: Tests at power frequencies*

IEC 60250, *Recommended methods for the determination of the permittivity and dielectric dissipation factor of electrical insulating materials at power, audio and radio frequencies including metre wavelengths*

IEC 60296, *Fluids for electrotechnical applications — Unused mineral insulating oils for transformers and switchgear*

IEC 60695-11-10, *Fire hazard testing — Part 11-10: Test flames — 50 W horizontal and vertical flame test methods*

IEC 60695-11-20, *Fire hazard testing — Part 11-20: Test flames — 500 W flame test methods*

3 Preparation of test specimens

3.1 General

This procedure is used only for the determination of crosslinked-resin properties.

It is essential that specimens are always prepared by the same procedure, using the same processing conditions. The specimens on which the properties are measured shall be cut from sheets of crosslinked resin, produced by a casting process. In view of the numerous possible fields of application for epoxy resins, the choice was made to prepare test specimens from resins not containing any filler or reinforcement in order to obtain the intrinsic properties of the crosslinked polymer, free of structural additives.

Sheets of thermosetting resin shall be manufactured at 2 mm, 3 mm and 4 mm thickness, as required, for the tests in Table 1. A sufficient number shall be produced to determine those properties required.

3.2 Pretreatment of materials

Before casting, no treatment of the epoxy resin sample is normally necessary. If a pretreatment is required, this shall be in accordance with the manufacturer's recommendations.

3.3 Preparation of test sheets

3.3.1 Apparatus

3.3.1.1 Two glass plates or two polished stainless-steel plates, each having a thickness of 6 mm and approximate dimensions of 300 mm × 350 mm.

Other materials, such as silicone, may also be used.

3.3.1.2 Shims, having a thickness of 2 mm, 3 mm and 4 mm.

3.3.1.3 Silicone or latex joint, having a diameter of 5 mm.

3.3.1.4 Device for clamping and holding the plates.

3.3.1.5 Device for removing air bubbles from the reaction mixture (see 3.3.3.4), preferably a centrifuge, or a vacuum dessicator allowing the plate/joint/shim assembly to be put under a static vacuum.

3.3.1.6 Stirrer, for mixing the resin and crosslinking agent (e.g. a glass rod).

3.3.1.7 Glass beaker, capacity 500 ml.

3.3.1.8 Laboratory balance, accurate to 0,1 g.

3.3.1.9 Laboratory oven, set at the temperature chosen for carrying out the post-treatment of the epoxy resin.

3.3.2 Reagents

3.3.2.1 Crosslinking agent, specific to epoxy resins (e.g. methyltetrahydrophthalic anhydride) (see warning in 3.3.3.5).

3.3.2.2 Crosslinking accelerator, e.g. 2,4,6-tris(dimethylaminomethyl)phenol or *N,N*-dimethyl-benzylamine.

3.3.2.3 External release agent, which does not modify the properties of the crosslinked resin.

3.3.3 Procedure

3.3.3.1 Coat the plates (3.3.1.1) with a thin layer of release agent (3.3.2.3). Polish them until they shine in order to ensure that the crosslinked-resin sheet produced has a high-quality surface finish.

3.3.3.2 Arrange the silicone or latex joint (3.3.1.3) and the selected shim (2 mm, 3 mm or 4 mm) (3.3.1.2) between the two plates as shown in Figure 1. Clamp the assembly with a suitable clamp (3.3.1.4) and position vertically.

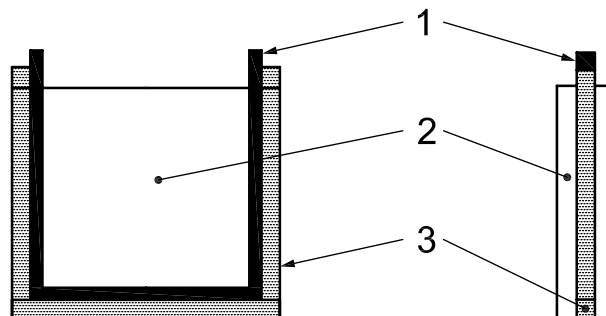

Key

- 1 joint
- 2 glass or steel plates
- 3 shims

Figure 1 — Apparatus for preparing test sheets

3.3.3.3 Using a laboratory balance (3.3.1.8), weigh the following reagents into a glass beaker (3.3.1.7):

- 100 g of epoxy resin;
 - methyltetrahydrophthalic anhydride at an anhydride/epoxy equivalent ratio of 0,9/1;
 - 0,5 phr (parts per hundred parts of epoxy resin, by mass) of 2,4,6-tris(dimethylaminomethyl)phenol;
- or
- 2 phr (parts per hundred parts of epoxy resin, by mass) of *N,N*-dimethylbenzylamine.

Using the stirrer (3.3.1.6), mix until homogeneous, avoiding the introduction of air bubbles as much as possible.

3.3.3.4 Remove any air bubbles from the mixture using the centrifuge (see 3.3.1.5), then carefully pour the mixture into the plate/joint/shim assembly without trapping any air bubbles in the resin. In the absence of a centrifuge, once the assembly is filled with the reactant mixture, place it vertically in a vacuum desiccator (see 3.3.1.5) and apply a static vacuum for the time required to remove all air bubbles.

When the viscosity of the mixture is high, air bubbles can be removed at an elevated temperature (e.g. 100 °C). In this case, the amount of accelerator has to be decreased. For example, use 0,25 phr of 2,4,6-tris(dimethylaminomethyl)phenol or 1 phr of *N,N*-dimethylbenzylamine.

3.3.3.5 Maintain the assembly in the vertical position while crosslinking in the laboratory oven (3.3.1.9). If using methyltetrahydrophthalic anhydride with 2,4,6-tris(dimethylaminomethyl)phenol or *N,N*-dimethylbenzylamine for crosslinking, carry out the heat treatment for 2 h at 100 °C followed by 15 h at 150 °C.

WARNING — Fumes from the crosslinking agent (methyltetrahydrophthalic anhydride) irritate the respiratory system and skin. Use ventilation and wear protective masks, gloves and goggles.

3.4 Cutting out test specimens

Cut test specimens from the prepared sheets (thickness 2 mm, 3 mm or 4 mm) in accordance with ISO 2818.

3.5 Conditioning test specimens

Unless otherwise specified, condition the test specimens for at least 16 h at 23 °C ± 2 °C and (50 ± 5) % relative humidity prior to determining the properties in Table 1.

4 Determination of properties

4.1 Properties are presented in Table 1.

4.2 In the determination of intrinsic properties, the presentation of results, the standards, and the supplementary instructions and notes given in ISO 10350-1:2007 shall be applied. All the tests shall be carried out at 23 °C ± 2 °C and 50 % ± 5 % relative humidity unless specifically stated otherwise in Table 1. Table 1 is taken from ISO 10350-1:2007 and the properties listed are those which are appropriate to epoxy-based products. These properties are those considered useful for comparisons of data generated for different thermosets and thermoplastics.

Table 1 — Intrinsic properties and test conditions

	Property	Symbol	Standard	Specimen type (dimensions in mm)	Unit	Test conditions and supplementary instructions	
1	Rheological properties						
1.1	Moulding shrinkage of thermosetting polymers	S_{Mp}	ISO 2577	See ISO 2577	%	Parallel	
1.2		S_{Mn}				Normal	
2	Mechanical properties						
2.1	Tensile modulus	E_t	ISO 527-2	ISO 3167, type A	MPa	Test speed 1 mm/min	
2.2	Stress at break	σ_B			MPa	Failure without yielding $\epsilon_B \leq 10\%$: test speed 5 mm/min $\epsilon_B > 10\%$: test speed 50 mm/min	
2.3	Strain at break	ϵ_B			%		
2.4	Flexural modulus	E_f	ISO 178	80 × 10 × 4	MPa	Test speed 2 mm/min Optional extra information for brittle materials	
2.5	Flexural strength	σ_M					
2.6	Charpy impact strength	a_{cU}	ISO 179-1 or ISO 179 2	80 × 10 × 4	kJ/m ²	Edgewise impact Also record type of failure	
2.7	Charpy notched impact strength	a_{cA}		Machined type A V-notch, $r = 0,25$			
3	Thermal properties						
3.1	Glass transition temperature	T_g	ISO 11357-2	Moulding compound	°C	Record midpoint temperature Use 10 °C/min	
3.2	Temperature of deflection under load	$T_f 1,8$	ISO 75-2	80 × 10 × 4	°C	1,80	Maximum surface stress (MPa)
3.3		$T_f 8,0$				8,0	
3.4	Coefficient of linear thermal expansion	α_p	ISO 11359-2	Prepared from ISO 3167	°C ⁻¹	Parallel	Record secant value over the temperature range 23 °C to 55 °C
		α_n				Transverse	
3.5	Burning behaviour	B50/3	IEC 60695-11-10	125 × 13 × 3		Record one of the classifications V-0, V-1, V-2, HB40 or HB75	
B50/h		Greater thickness h					
3.6		B500/3	IEC 60695-11-20	≥ 150 × ≥ 150 × 3			
B500/h	Greater thickness h						
3.7	Oxygen index	OI	ISO 4589-2	80 × 10 × 4	%	Use procedure A (top surface ignition)	
4	Electrical properties						
4.1	Relative permittivity	$\epsilon_r 100$	IEC 60250	≥ 60 × ≥ 60 × 2		100 Hz	Compensate for electrode edge effects
		$\epsilon_r 1M$				1 MHz	
4.2	Dissipation factor	$\tan \delta 100$				100 Hz	
		$\tan \delta 1M$				1 MHz	
4.3	Volume resistivity	ρ_e	IEC 60093	≥ 60 × ≥ 60 × 2	Ω·m	1-minute value	
4.4	Surface resistivity	δ_e			Ω	Voltage 500 V	Use contacting line electrodes 1 mm to 2 mm wide, 50 mm long and 5 mm apart
4.5	Electric strength	E_{B1}	IEC 60243-1	≥ 60 × ≥ 60 × 1	kV/mm	Use 20-mm-diameter spherical electrodes. Immerse in transformer oil in accordance with IEC 60296. Use a voltage application rate of 2 kV/s.	
		E_{B2}		≥ 60 × ≥ 60 × 2			
4.6	Comparative tracking index	CTI	IEC 60112	≥ 20 × ≥ 20 × 4		Use solution A	
5	Other properties						
5.1	Water absorption	W_W	ISO 62	Thickness ≥ 1	%	Saturation value in water at 23 °C	
		W_H				Equilibrium value at 23 °C, 50 % RH	

Bibliography

- [1] ISO 18280, *Plastics — Epoxy resins — Test methods*

.....

.....

ICS 83.080.10

Price based on 6 pages