**Dentistry — Endodontic
instruments —**

**Part 2:
Enlargers**

*Médecine bucco-dentaire — Instruments d'endodontie —
Partie 2: Élargisseurs*



Reference number
ISO 3630-2:2013(E)



COPYRIGHT PROTECTED DOCUMENT

© ISO 2013

All rights reserved. Unless otherwise specified, no part of this publication may be reproduced or utilized otherwise in any form or by any means, electronic or mechanical, including photocopying, or posting on the internet or an intranet, without prior written permission. Permission can be requested from either ISO at the address below or ISO's member body in the country of the requester.

ISO copyright office
Case postale 56 • CH-1211 Geneva 20
Tel. + 41 22 749 01 11
Fax + 41 22 749 09 47
E-mail copyright@iso.org
Web www.iso.org

Published in Switzerland

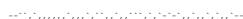

© ISO 2013 – All rights reserved

Contents

Page

Foreword	iv
Introduction	v
1 Scope	1
2 Normative references	1
3 Terms, definitions and symbols	1
3.1 Terms and definitions.....	1
3.2 Symbols.....	2
4 Classification	2
4.1 Enlarger Type B1.....	2
4.2 Enlarger Type B2.....	2
4.3 Enlarger Type G.....	2
4.4 Enlarger Type M.....	2
4.5 Enlarger Type P.....	2
5 Requirements	2
5.1 Materials.....	2
5.2 Dimensions, designation and number of blades.....	3
5.3 Mechanical requirements.....	9
6 Sampling	10
7 Testing	10
7.1 General.....	10
7.2 Dimensions.....	10
7.3 Resistance to fracture by twisting and angular deflection.....	11
7.4 Resistance to bending.....	11
7.5 Resistance to fatigue.....	11
7.6 Fracture location.....	11
8 Designation, marking and identification	13
9 Packaging	14
10 Labelling	14
Bibliography	15

Foreword

ISO (the International Organization for Standardization) is a worldwide federation of national standards bodies (ISO member bodies). The work of preparing International Standards is normally carried out through ISO technical committees. Each member body interested in a subject for which a technical committee has been established has the right to be represented on that committee. International organizations, governmental and non-governmental, in liaison with ISO, also take part in the work. ISO collaborates closely with the International Electrotechnical Commission (IEC) on all matters of electrotechnical standardization.

International Standards are drafted in accordance with the rules given in the ISO/IEC Directives, Part 2.

The main task of technical committees is to prepare International Standards. Draft International Standards adopted by the technical committees are circulated to the member bodies for voting. Publication as an International Standard requires approval by at least 75 % of the member bodies casting a vote.

Attention is drawn to the possibility that some of the elements of this document may be the subject of patent rights. ISO shall not be held responsible for identifying any or all such patent rights.

ISO 3630-2 was prepared by Technical Committee ISO/TC 106, *Dentistry*, Subcommittee SC 4, *Dental instruments*.

This third edition cancels and replaces the second edition (ISO 3630-2:2000), which has been technically revised.

The following changes were made:

- a) tolerances for diameter measurements were aligned;
- b) test procedures were aligned with ISO 3630-1.

ISO 3630 consists of the following parts, under the general title *Dentistry — Endodontic instruments*:

- *Part 1: General requirements and test methods*
- *Part 2: Enlargers*
- *Part 3: Condensers, pluggers and spreaders*
- *Part 4: Auxiliary instruments*
- *Part 5: Shaping and cleaning instruments*

Introduction

Specific qualitative and quantitative requirements for freedom from biological hazard are not included in this International Standard but it is recommended that, in assessing possible biological or toxicological hazards, reference be made to ISO 10993-1 and ISO 7405.

Attention is drawn to ISO 6360 (all parts) which specifies a 15-digit number for the identification of dental rotary instruments of all types.

Dentistry — Endodontic instruments —

Part 2: Enlargers

1 Scope

This part of ISO 3630 specifies requirements for enlargers not cited in ISO 3630-1, ISO 3630-3, ISO 3630-4 or ISO 3630-5.

This part of ISO 3630 specifies requirements for size, marking, product designation, safety considerations, and their labelling and packaging, including the instructions for use.

2 Normative references

The following documents, in whole or in part, are normatively referenced in this document and are indispensable for its application. For dated references, only the edition cited applies. For undated references, the latest edition of the referenced document (including any amendments) applies.

ISO 1797-1, *Dentistry — Shanks for rotary instruments — Part 1: Shanks made of metals*

ISO 1797-2, *Dental rotary instruments — Shanks — Part 2: Shanks made of plastics*

ISO 1942, *Dentistry — Vocabulary*

ISO 3630-1:2008, *Dentistry — Root-canal instruments — Part 1: General requirements and test methods*

ISO 15223-1, *Medical devices — Symbols to be used with medical device labels, labelling and information to be supplied — Part 1: General requirements*

3 Terms, definitions and symbols

3.1 Terms and definitions

For the purposes of this document, the terms and definitions given in ISO 1942, ISO 3630-1 and the following apply.

3.1.1

enlarger

hand- or power-operated endodontic instrument used for improving access to the root canal by enlarging its coronal opening

3.2 Symbols

For the purposes of this document, the following symbols apply. All dimensions are in millimetres (see [Figures 1 to 5](#) and [Tables 1 to 10](#)).

- d_1 diameter of working part (head diameter);
- d_2 neck diameter, measured at the proximal end of the working part;
- d_3 neck diameter, measured at the proximal end of the operative end;
- d_4 tip diameter;
- l_1 distance from tip to section A-A (at maximum diameter d_1);
- l_2 maximum length of working end and the measuring distance of d_2 (head length);
- l_3 minimum length of operative end and the measuring distance of d_3 ;
- l_4 total length of the instrument.

4 Classification

4.1 Enlarger Type B1

This enlarger has no other name attributed to it.

4.2 Enlarger Type B2

This enlarger has no other name attributed to it.

4.3 Enlarger Type G

This enlarger is also known as a Gates-Glidden drill.

4.4 Enlarger Type M

This enlarger has no other name attributed to it.

4.5 Enlarger Type P

This enlarger is also known as a Peeso drill.

5 Requirements

5.1 Materials

5.1.1 Shank or handle

The material(s) of the shank or handle shall be left to the discretion of the manufacturer but shall meet the requirement in ISO 3630-1:2008, 5.7.

The shank or handle of the enlarger shall be Type 1 or Type 2 of ISO 1797-1 or ISO 1797-2.

5.1.2 Working part

The working part of the instrument shall be made of stainless steel, corrosion-resistant metal, or any other material, provided it meets the requirements given in [5.2](#) and [5.3](#).

5.2 Dimensions, designation and number of blades

5.2.1 General

All linear dimensions are given in millimetres, all angles in degrees. The linear dimensions in millimetres shall comply with [Figures 1 to 5](#) and [Tables 1 to 10](#).

The lengths of the working part and the operative part shall be specified by the manufacturer and shall be within $\pm 0,5$ mm of the specified lengths.

Test compliance in accordance with ISO 3630-1. ISO 3630-1:2008, Table 1, gives the series of nominal diameters for the working part and the corresponding designation to be used, for all Types of dental endodontic instruments specified in ISO 3630-2, ISO 3630-3, ISO 3630-4 and ISO 3630-5.

NOTE Variations in shape and design within the limits of the dimensions and the subclass titles are permitted.

5.2.2 Enlarger types

5.2.2.1 Enlarger Type B1

Requirements for enlargers of Type B1 are given in [Figure 1](#) and [Tables 1](#) and [2](#).

5.2.2.2 Enlarger Type B2

Requirements for enlargers of Type B2 are given in [Figure 2](#) and [Tables 3](#) and [4](#).

5.2.2.3 Enlarger Type G

Requirements for enlargers of Type G are given in [Figure 3](#) and [Tables 5](#) and [6](#).

5.2.2.4 Enlarger Type M

Requirements for enlargers of Type M are given in [Figure 4](#) and [Tables 7](#) and [8](#).

5.2.2.5 Enlarger Type P

Requirements for enlargers of Type P are given in [Figure 5](#) and [Tables 9](#) and [10](#).

Dimensions in millimetres

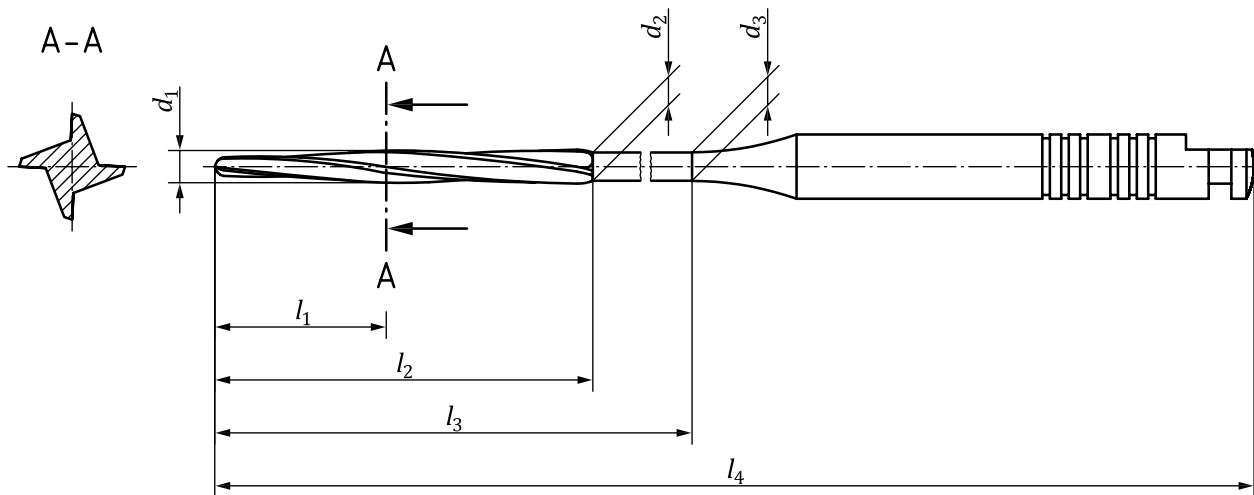

NOTE The shank shown is an example of Type 1 of ISO 1797-1 with six-ring marking.

Figure 1 — Enlarger Type B1

Table 1 — Enlarger Type B1: Dimensions, number of blades and designation

Dimensions in millimetres

Nominal size	d_1	d_2	d_3	l_1	l_2	Number of blades	Colour	Ring marking
	$\pm 0,05$	+0,05 -0	+0 -0,05	$\pm 0,05$	min.			
090	0,90	0,75	0,75	4,50	10,0	4	white	I
100	1,00	0,85	0,85	4,50		4	yellow	II
120	1,20	1,05	1,05	4,50		4	red	III
140	1,40	1,20	1,20	4,75		4	blue	III I
160	1,60	1,40	1,40	4,75		4	green	III II
180	1,80	1,60	1,60	4,75		4	black	III III

Table 2 — Enlarger Type B1: Lengths l_3 and l_4

Dimensions in millimetres

Shank (ISO 1797-1)	l_3 min.	l_4
Type 1	13	$34 \pm 0,5$
Type 2	26	$65 \pm 1,0$

Dimensions in millimetres

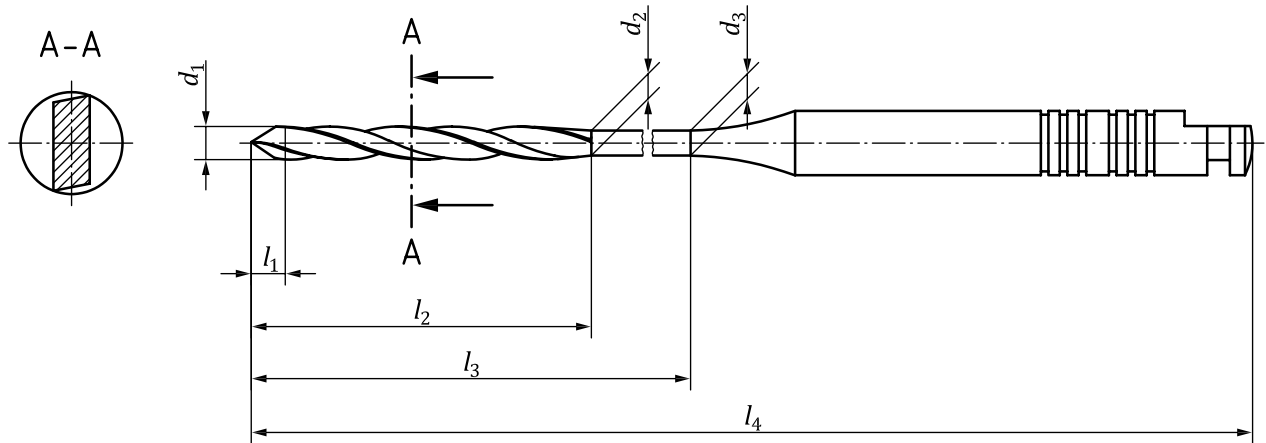

NOTE The shank shown is an example of Type 1 of ISO 1797-1 with six-ring marking.

Figure 2 — Enlarger Type B2

Table 3 — Enlarger Type B2: Dimensions and designation

Dimensions in millimetres

Nominal size	d_1	d_2	d_3	l_1	l_2	Colour	Ring marking
	$\pm 0,05$	$+0,05$ -0	$+0$ $-0,05$	$\pm 0,05$	min.		
030	0,30	0,20	0,20	0,50	7,5	purple	0
035	0,35	0,26	0,26	0,50	8,0	white	I
045	0,45	0,36	0,36	0,50	8,0	yellow	II
060	0,60	0,46	0,46	0,70	8,0	red	III
075	0,75	0,56	0,56	0,80	9,0	blue	III I
090	0,90	0,66	0,66	1,00	9,0	green	III II
105	1,05	0,76	0,76	1,10	10,0	black	III III

Table 4 — Enlarger Type B2: Lengths l_3 and l_4

Dimensions in millimetres

Shank (ISO 1797-1)	l_3	l_4
Type 1	$18 \pm 0,5$	$33 \pm 0,5$
Type 2	min. 25	$61 \pm 1,0$

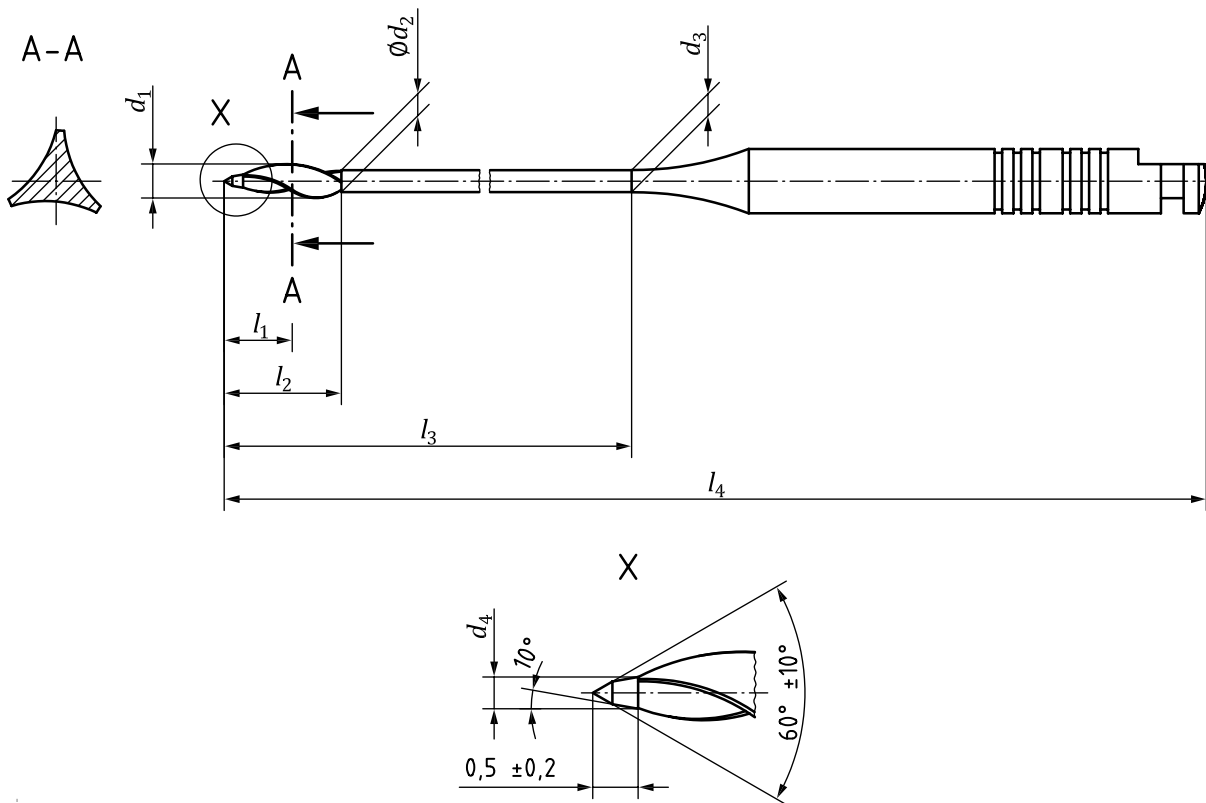

NOTE The shank shown is an example of Type 1 of ISO 1797-1 with six-ring marking.

Figure 3 — Enlarger Type G

Table 5 — Enlarger Type G: Dimensions, number of blades and designation

Dimensions in millimetres

Nominal size	d_1	d_2	d_3	d_4	l_1	l_2	Number of blades	Colour	Ring marking
	$\pm 0,05$	$+0$ $-0,05$	$+0$ $-0,05$	$\pm 0,05$	$\pm 0,05$	min.			
050	0,50	0,38	0,38	0,25	1,50	2,3	3	white	I
070	0,70	0,48	0,48	0,30	1,70	2,7	3	yellow	II
090	0,90	0,58	0,58	0,35	1,90	3,1	3	red	III
110	1,10	0,68	0,68	0,40	2,10	3,5	3	blue	III I
130	1,30	0,78	0,78	0,45	2,30	3,9	3	green	III II
150	1,50	0,87	0,87	0,50	2,50	4,3	3	black	III III

Table 6 — Enlarger Type G: Lengths l_3 and l_4

Dimensions in millimetres

Shank (ISO 1797)	l_3 min.	l_4
Type 1	15,2	$32 \pm 0,5$
Type 2	15,2	$60,5 \pm 1,0$

Dimensions in millimetres

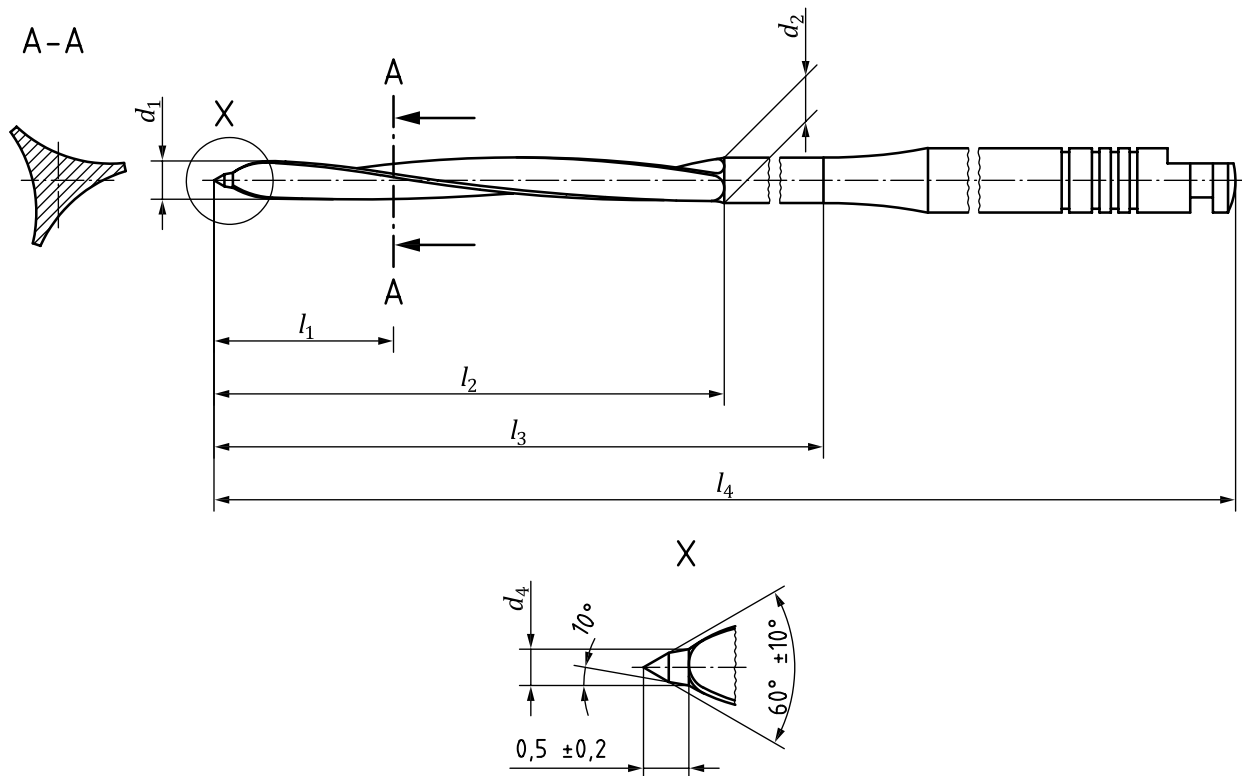

NOTE The shank shown is an example of Type 1 of ISO 1797-1 with four-ring marking.

Figure 4 — Enlarger Type M

Table 7 — Enlarger Type M: Dimensions and designation

Dimensions in millimetres

Nominal size	d_1	d_2	d_4	l_1	l_2	Colour	Ring marking
	$\pm 0,05$	$+0,05$ -0	$\pm 0,05$	$\pm 0,05$	min.		
120	1,20	1,00	0,40	4,75	13,0	white	I
140	1,40	1,15	0,45	4,75	13,0	yellow	II
165	1,65	1,30	0,50	4,75	13,0	red	III
190	1,90	1,45	0,55	4,75	13,0	blue	III I

Table 8 — Enlarger Type M: Lengths l_3 and l_4

Dimensions in millimetres

Shank (ISO 1797-1)	l_3 min.	l_4
Type 1	19	$33 \pm 0,5$

Dimensions in millimetres

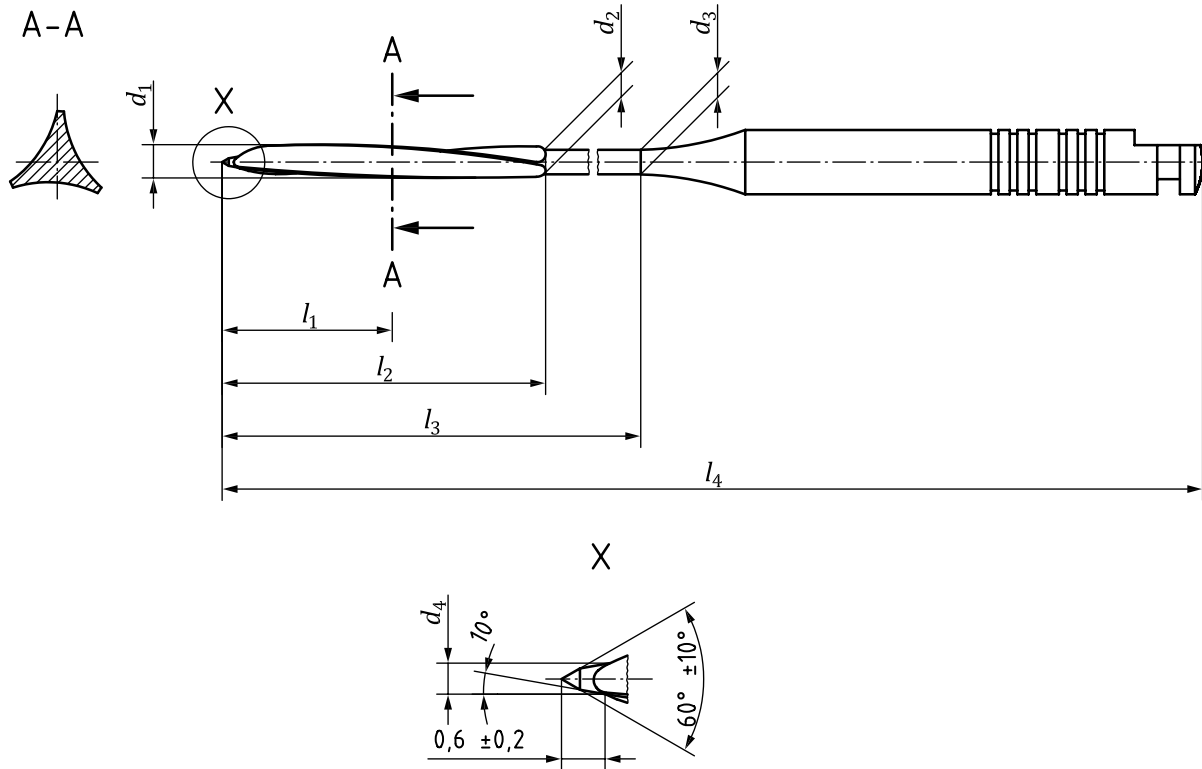

NOTE The shank shown is an example of Type 1 of ISO 1797-1 with six-ring marking.

Figure 5 — Enlarger Type P

Table 9 — Enlarger Type P: Dimensions, number of blades and designation

Dimensions in millimetres

Nominal size	d_1	d_2	d_3	d_4	l_1	l_2	Number of blades	Colour	Ring marking
	$\pm 0,05$	$+0,05$ -0	$+0$ $-0,05$	$\pm 0,05$	$\pm 0,05$	min.			
070	0,70	0,60	0,60	0,25	4,50	8,5	3	white	I
090	0,90	0,65	0,65	0,30	4,50	8,5	3	yellow	II
110	1,10	0,75	0,75	0,35	4,50	8,5	3	red	III
130	1,30	0,90	0,90	0,40	4,75	9,0	3	blue	III I
150	1,50	1,00	1,00	0,45	4,75	9,0	3	green	III II
170	1,70	1,10	1,10	0,50	4,75	9,0	3	black	III III

Table 10 — Enlarger Type P: Lengths l_3 and l_4

Dimensions in millimetres

Shank (ISO 1797)	l_3 min.	l_4
Type 1	13	$32 \pm 0,5$
Type 2	26	$60,5 \pm 1,0$

5.3 Mechanical requirements

5.3.1 Resistance to fracture by twisting and angular deflection

When tested in accordance with [7.3](#), the enlarger shall not fracture at less than the minimum value for the resistance to fracture in torque and the minimum angular deflection given in [Table 11](#), and shall meet the requirements of [5.3.4](#).

5.3.2 Resistance to bending

When tested in accordance with [7.4](#), the instrument shall not fracture and shall not exceed the values specified in [Table 11](#) except for Type M.

5.3.3 Resistance to fatigue

When tested in accordance with [7.5](#), the instrument shall meet the requirements of [5.3.4](#). The minimum number of test revolutions shall be the value given in [Table 11](#) except for Type M.

5.3.4 Fracture location

When tested for requirements [5.3.1](#) and [5.3.3](#), the instrument shall fracture within 4 mm of l_3 of the operative end and the shank, as shown in [Figures 1](#) to [4](#).

Enlarger Type M is excluded from this requirement.

Table 11 — Resistance to fracture by twisting, stiffness and fatigue test

Enlarger Type	Nominal size	Twisting moment	Angular deflection test	Stiffness test	Fatigue test
		torque mN·m min.	angular deflection degrees min.	torque mN·m max.	revolutions min.
Type G	050	10	360	22	3 500
Type G	070	23	360	26	2 000
Type G	090	43	360	30	950
Type G	110	73	180	30	300
Type P	070	17,6	90	35	200
Type P	090	54	240	35	130
Type P	110	84	240	35	30
Type B1	090	10	90	30	1 000
Type B1	100	40	90	35	1 000
Type B2	030	1,8	360	10	100
Type B2	035	3,0	360	10	100
Type B2	045	9,8	360	15	100
Type B2	060	15,7	360	20	100
Type B2	075	24,5	360	25	100
Type B2	090	29,4	360	25	100
Type B2	105	49	360	30	100

6 Sampling

For each test, unless otherwise specified, at least 95 % of the samples tested shall comply. The sampling plan is as follows:

Test 10 instruments of each size. If all 10 samples pass, the product passes. If eight or fewer samples pass, the product fails. If nine samples pass, test 10 additional samples. When 10 additional samples are to be tested, all 10 shall pass for the product to comply.

7 Testing

7.1 General

The instrument samples and equipment shall comply with ISO 3630-1:2008, Clause 7.

7.2 Dimensions

7.2.1 Diameters

Measure the diameters d_1 , d_2 , and d_3 . Record the dimensions of the 10 enlargers in millimetres of each size to be tested.

7.2.2 Tip

Following the procedure given in [7.2.1](#), rotate the instrument until the tip length is at the maximum. Measure the tip diameter d_4 , tip angle and tip length in millimetres as shown in [Tables 1, 3, and 9](#) and in [Figures 1, 2, and 5](#).

7.2.3 Shank or handle

Measure the handle dimensions or measure the shank dimensions in accordance with ISO 1797-1 or ISO 1797-2. Determine the dimensions in millimetres shown in [Figures 1 to 5](#) and check if they comply with the dimensions specified in ISO 1797-1 or ISO 1797-2.

7.2.4 Length

Following the procedure given in [7.2.2](#), measure the head length in millimetres by locating the longest end of the blade as listed in [Tables 1, 3, 5, 7 and 9](#) and shown in [Figures 1 to 5](#). Measure lengths l_3 and l_4 in millimetres as listed in [Tables 2, 4, 6, 8 and 10](#).

7.2.5 Blades

Hold the instrument and visually determine the number of blades when viewing around the circumference.

7.3 Resistance to fracture by twisting and angular deflection

Twist 10 enlargers in a clockwise direction in accordance with ISO 3630-1:2008, 7.4. Record the torque in milliNewton metres (mN·m) and the angular deflection in degrees. Test only instruments up to a nominal diameter of 1,10 mm (size 110).

7.4 Resistance to bending

Bend 10 instruments (see [Table 11](#)) using the apparatus for the torque test as shown in ISO 3630-1:2008, 7.5. Record the torque in milliNewton metres (mN·m) as a maximum value. Test only instruments up to a nominal diameter of 1,10 mm (size 110).

7.5 Resistance to fatigue

Test 10 instruments. Grip the shaft of the instrument in the chuck of a variable-speed motor ([Figure 6](#)) and place the head in the ball-bearing ring. Locate the centre of the ball bearing at l_1 as specified in [Figures 1, 2 and 3](#) for Types G, P and B1. For Type B2, locate the centre of the ball bearing 1,1 mm from the tip. Deflect the ball-bearing 2 mm away from the axial alignment with the motor ([Figure 7](#) and [Figure 8](#)). Rotate the motor at $(4\,000 \pm 400)$ rotations per minute (1/min). Count the total number of revolutions until failure ([Table 11](#)). Test only enlargers having a nominal diameter of up to 1,10 mm (size 110).

7.6 Fracture location

Measure and record the operative length in millimetres as described in [Figures 1 to 4](#) prior to testing in accordance with [7.3](#), [7.4](#) and [7.5](#). After testing, measure the distance from the instrument tip to the fracture point. Record the numerical difference between the operative length and the distance to the fracture point as the fracture location.

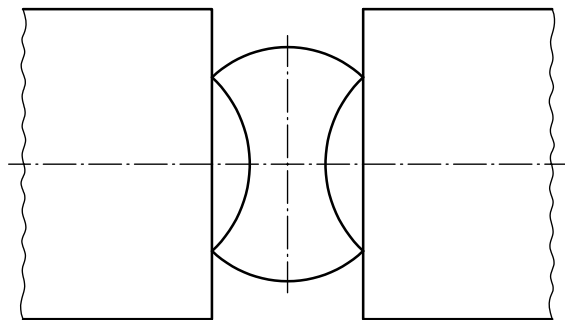
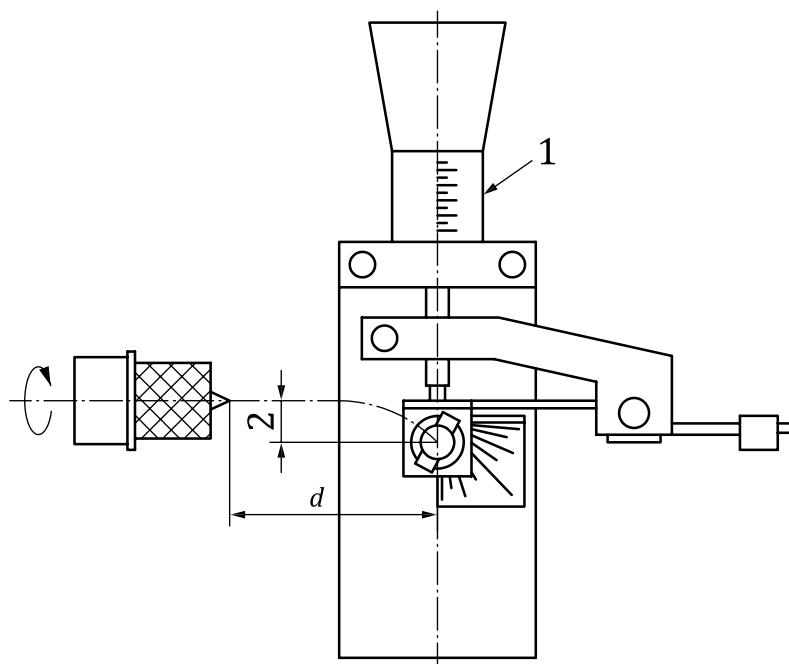

Figure 6 — Chucking position of instrument for testing twisting and angular deflection

Dimensions in millimetres



Key

1 micrometer scale, for setting deflection

$d = 16 \text{ mm}$

Figure 7 — Fatigue device (resistance to fatigue)

Dimensions in millimetres

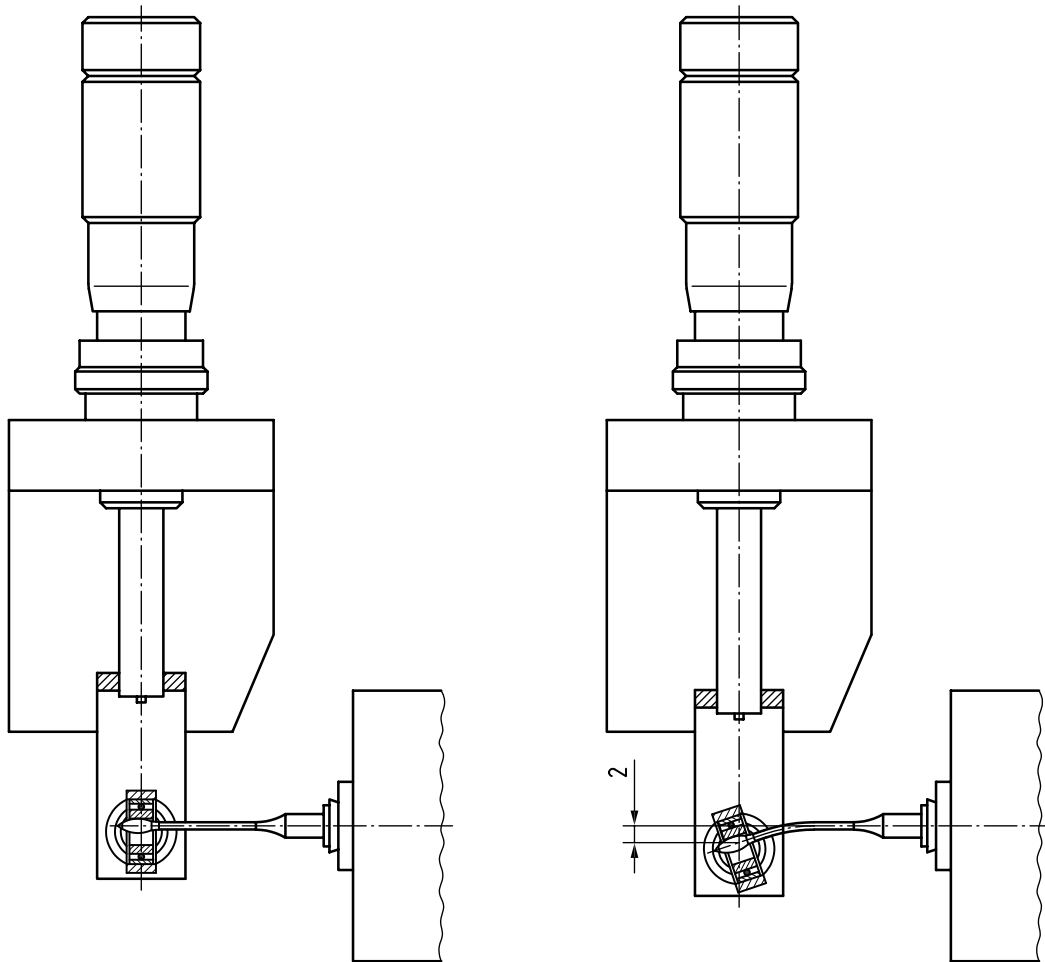

Figure 8 — Apparatus for testing resistance to fatigue

8 Designation, marking and identification

The nominal sizes of the enlargers shall be indicated by marking the shank as shown in [Table 12](#).

Table 12 — Size designation, colour coding and ring marking for enlargers

Nominal size	Type G		Type P		Type B1		Type B2		Type M	
	colour	rings	colour	rings	colour	rings	colour	rings	colour	rings
030							purple	0		
035							white	I		
045							yellow	II		
050	white	I								
060							red	III		
070	yellow	II	white	I						
075							blue	III I		
090	red	III	yellow	II	white	I	green	III II		
100					yellow	II				
105							black	III III		
110	blue	III I	red	III						
120					red	III			white	I
130	green	III II	blue	III I						
140					blue	III I			yellow	II
150	black	III III	green	III II						
160					green	III II				
165									red	III
170			black	III III						
180					black	III III				
190									blue	III I

9 Packaging

Packaging shall comply with the requirements of ISO 3630-1:2008, Clause 9.

10 Labelling

Labelling shall comply with the requirements of ISO 3630-1:2008, Clause 11.

Graphical symbols used shall be in accordance with ISO 15223-1.

Bibliography

- [1] ISO 6360-1, *Dentistry — Number coding system for rotary instruments — Part 1: General characteristics*
- [2] ISO 6360-2, *Dentistry — Number coding system for rotary instruments — Part 2: Shapes*
- [3] ISO 6360-5, *Dentistry — Number coding system for rotary instruments — Part 5: Specific characteristics of root-canal instruments*
- [4] ISO 8601, *Data elements and interchange formats — Information interchange — Representation of dates and times*

ICS 11.060.20

Price based on 15 pages