**Dentistry — Root-canal instruments —
Part 1:
General requirements and test methods**

*Art dentaire — Instruments pour canaux radiculaires —
Partie 1: Exigences générales et méthodes d'essai*



Reference number
ISO 3630-1:2008(E)

© ISO 2008

PDF disclaimer

This PDF file may contain embedded typefaces. In accordance with Adobe's licensing policy, this file may be printed or viewed but shall not be edited unless the typefaces which are embedded are licensed to and installed on the computer performing the editing. In downloading this file, parties accept therein the responsibility of not infringing Adobe's licensing policy. The ISO Central Secretariat accepts no liability in this area.

Adobe is a trademark of Adobe Systems Incorporated.

Details of the software products used to create this PDF file can be found in the General Info relative to the file; the PDF-creation parameters were optimized for printing. Every care has been taken to ensure that the file is suitable for use by ISO member bodies. In the unlikely event that a problem relating to it is found, please inform the Central Secretariat at the address given below.

.....



COPYRIGHT PROTECTED DOCUMENT

© ISO 2008

All rights reserved. Unless otherwise specified, no part of this publication may be reproduced or utilized in any form or by any means, electronic or mechanical, including photocopying and microfilm, without permission in writing from either ISO at the address below or ISO's member body in the country of the requester.

ISO copyright office
Case postale 56 • CH-1211 Geneva 20
Tel. + 41 22 749 01 11
Fax + 41 22 749 09 47
E-mail copyright@iso.org
Web www.iso.org

Published in Switzerland

Contents

Page

Foreword.....	iv
Introduction	v
1 Scope	1
2 Normative references	1
3 Terms, definitions and symbols	1
3.1 Terms and definitions.....	1
3.2 Symbols	3
4 Classification.....	3
5 Requirements	3
5.1 General.....	3
5.2 Type 1: standard-sized instruments	3
5.3 Type 2: taper-sized instruments.....	5
5.4 Type 3: shape-sized instruments	6
5.5 Type 4: non-taper-sized instruments.....	7
5.6 Type 5: non-uniform taper-sized instruments	8
5.7 Material	9
5.8 Dimensions.....	9
5.9 Mechanical requirements.....	9
5.10 Chemical requirements	10
6 Sampling.....	10
7 Testing	10
7.1 Visual inspection	10
7.2 Test conditions	10
7.3 Measurement of dimensions	11
7.4 Resistance to fracture by twisting and angular deflection.....	11
7.5 Stiffness	13
7.6 Handle and shank security	14
7.7 Corrosion test	14
7.8 Heat effects of sterilization	15
8 Designation, marking and identification	16
8.1 General.....	16
8.2 Identification symbols	16
9 Packaging	16
10 Manufacturer's instructions for use.....	16
11 Labelling	17
Bibliography	18

Foreword

ISO (the International Organization for Standardization) is a worldwide federation of national standards bodies (ISO member bodies). The work of preparing International Standards is normally carried out through ISO technical committees. Each member body interested in a subject for which a technical committee has been established has the right to be represented on that committee. International organizations, governmental and non-governmental, in liaison with ISO, also take part in the work. ISO collaborates closely with the International Electrotechnical Commission (IEC) on all matters of electrotechnical standardization.

International Standards are drafted in accordance with the rules given in the ISO/IEC Directives, Part 2.

The main task of technical committees is to prepare International Standards. Draft International Standards adopted by the technical committees are circulated to the member bodies for voting. Publication as an International Standard requires approval by at least 75 % of the member bodies casting a vote.

Attention is drawn to the possibility that some of the elements of this document may be the subject of patent rights. ISO shall not be held responsible for identifying any or all such patent rights.

ISO 3630-1 was prepared by Technical Committee ISO/TC 106, *Dentistry*, Subcommittee SC 4, *Dental instruments*.

This second edition cancels and replaces the first edition (ISO 3630-1:1992), which has been technically revised.

ISO 3630 consists of the following parts, under the general title *Dentistry — Root-canal instruments*:

- *Part 1: General requirements and test methods*
- *Part 2: Enlargers*
- *Part 3: Condensers, pluggers and spreaders*
- *Part 4: Auxiliary instruments*

Introduction

The reorganization of ISO 3630 is intended to present the requirements and test methods for root-canal instruments in an orderly manner. This part of ISO 3630 defines general requirements and test methods. Subsequent parts provide the specific requirements and test methods, if applicable, for two areas of endodontic procedures. These parts are enlargers, condensers and auxiliary instruments.

With current use of nickel-titanium (Ni-Ti) alloys for manufacture of root canal instruments a need for adequate expertise in their safe use is recommended. Instruments made of Ni-Ti can be easily broken near the tip if manufacturer's cautions are not understood and practiced. This part of ISO 3630 does not attempt to provide information for proper use of any instruments.

The sizes of the root-canal obturating points (cones) specified in ISO 6877^[4] have to be aligned with the corresponding sizes for root-canal instruments specified in ISO 3630.

.....

Dentistry — Root-canal instruments —

Part 1: General requirements and test methods

1 Scope

This part of ISO 3630 specifies general requirements and test methods for root-canal instruments used for endodontic purposes, e.g. enlargers, shaping and cleaning instruments, condensers, and accessory instruments. In addition it covers general size designations, colour coding, packaging and identification symbols.

2 Normative references

The following referenced documents are indispensable for the application of this document. For dated references, only the edition cited applies. For undated references, the latest edition of the referenced document (including any amendments) applies.

ISO 554, *Standard atmospheres for conditioning and/or testing — Specifications*

ISO 1942, *Dental vocabulary* (all parts)

ISO 1797-1:1992, *Dental rotary instruments — Shanks — Part 1: Shanks made of metals*

ISO 1797-2:1992, *Dental rotary instruments — Shanks — Part 2: Shanks made of plastics*

ISO 3630-2:2000, *Dental root-canal instruments — Part 2: Enlargers*

ISO 3696:1987, *Water for analytical laboratory use — Specification and test methods*

ISO 6360-2, *Dentistry — Number coding system for rotary instruments — Part 2: Shapes*

ISO 8601, *Data elements and interchange formats — Information interchange — Representation of dates and times*

ISO 13402, *Surgical and dental hand instruments — Determination of resistance against autoclaving, corrosion and thermal exposure*

ISO 15223-1, *Medical devices — Symbols to be used with medical device labels, labelling and information to be supplied — Part 1: General requirements*

3 Terms, definitions and symbols

3.1 Terms and definitions

For the purposes of this document, the terms and definitions given in ISO 1942 and the following apply.

3.1.1

**root-canal instrument
endodontic instrument**

dental instrument designed to explore, shape, clean and fill root canal systems

3.1.2

standard-sized instrument

root-canal instrument throughout the range of sizes available having a uniform taper of 0,02 mm per millimetre of length

NOTE The nominal size of the root-canal instrument is listed in Table 1.

3.1.3

non standard-sized instrument

root-canal instrument which has other tip sizes than the standard-sized instrument

NOTE The nominal size of the root-canal instrument is not listed in Table 1.

3.1.4

taper-sized instrument

root-canal instrument the sizes of which are determined by the tip sizes that have tapers other than 0,02 mm per millimetre of length

3.1.5

shape-sized instrument

root-canal instrument having a contoured working part with continuously varying profile

3.1.6

non taper-sized instrument

root-canal instrument having a cylindrical form along the long axis

3.1.7

non-uniform taper-sized instrument

root-canal instrument having more than one taper along the working part

3.1.8

flexible instrument

root-canal instrument whose average test value when tested according to 7.5, shall be 65 %, or less, of the value listed in the appropriate bending or stiffness table of referenced specifications

3.1.9

guided tip instrument

root-canal instrument having a tip which guides access within root canal systems

3.1.10

tip portion of the instrument

that part of the root-canal instrument which is intended as the point, the shape of which is at the discretion of the manufacturer

3.1.11

working part

portion of the root-canal instrument with an active cutting surface

3.1.12

shank

part of the root-canal instrument to be connected to a handpiece

3.1.13

handle

part of the root-canal instrument to be manipulated by the user by hand

3.1.14**operative part**

portion of the root-canal instrument from the tip to the handle or shank

3.2 Symbols

For the purposes of this document, the following symbols apply.

d_1 diameter of the projection of the working part at the tip end (reference size);

d_2 diameter at length l_2 ;

d_3 diameter at the end of minimum length of working part, length l_3 ;

l_1 tip length;

l_2 length for measuring point d_2 ;

l_3 length for measuring point d_3 and minimum length of working part;

l_4 length of operative part.

4 Classification

For the purposes of this document, root-canal instruments are classified according to the shape and taper of the tip size (see Figure 1) as follows.

- Type 1: standard-sized instruments (taper = 2 %);
- Type 2: taper-sized instruments (taper other than 2 %);
- Type 3: shape-sized instruments (arc shape);
- Type 4: non-taper-sized instruments (zero taper);
- Type 5: non-uniform taper-sized instruments (more than one taper).

5 Requirements**5.1 General**

Specific root-canal instrument types, such as enlargers, have unique shapes which are not included here. These cases are covered in ISO 3630-2 and ISO 3630-3.

5.2 Type 1: standard-sized instruments**5.2.1 Length**

The length of the working part, l_3 , shall be a minimum of 16 mm unless otherwise specified by the manufacturer. The lengths of the working part, when specified, and of the operative part, l_4 , shall be within $\pm 0,5$ mm of the specified lengths.

Test in accordance with 7.3.

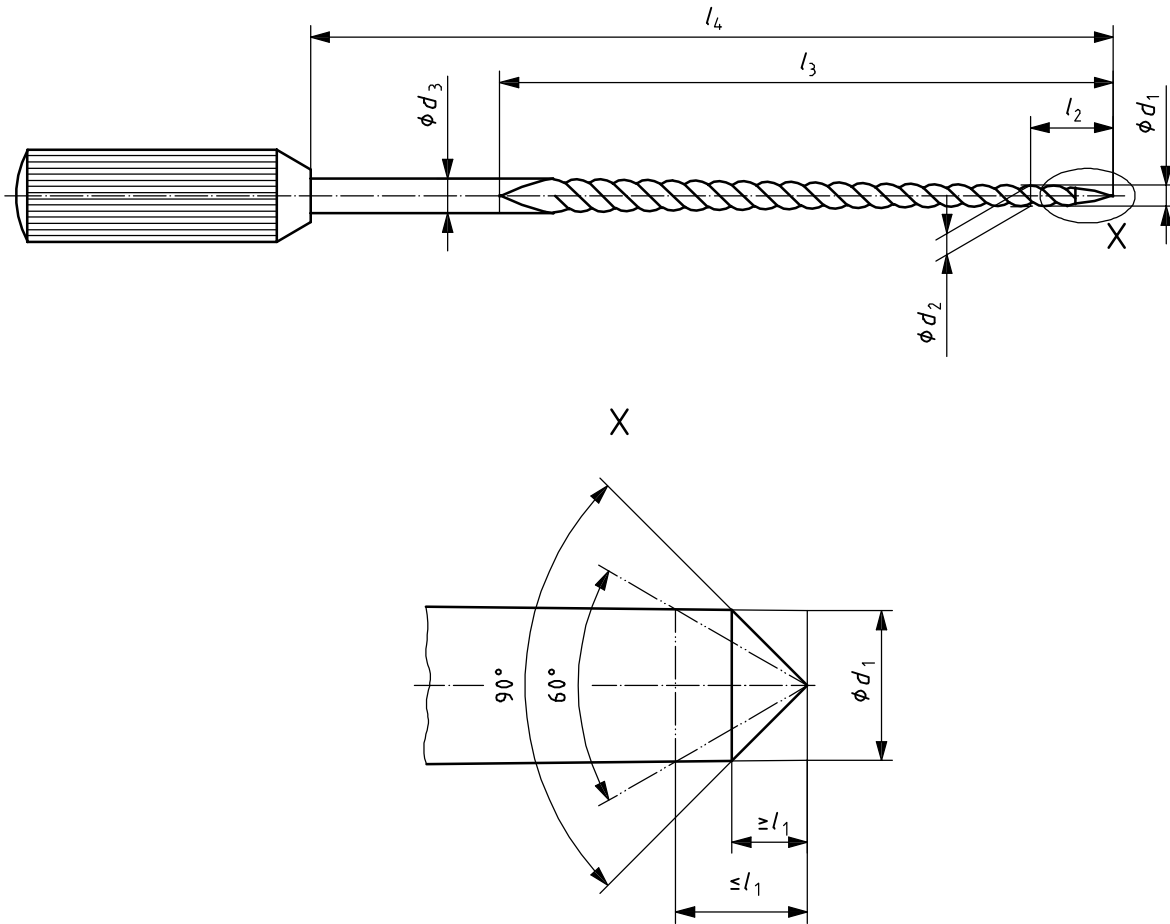

Figure 1 — Dimensions and locations for Type 1
(standard-sized instruments; taper = 2 %)

5.2.2 Size designation and diameters

Table 1 gives the nominal sizes and dimensions for the working part to be used for Type 1 (standard-sized instruments). Tip sizes (d_1) other than those listed in Table 1 are permitted. Figure 1 shows the position of the diameters and lengths for all Type 1 root-canal instruments. The nominal sizes shall correspond to the values of the extended diameters at the tip of the working part in hundredths of a millimetre.

NOTE The designation (code number) with three digits is part of the 15-digit identification number specified in ISO 6360-1 and ISO 6360-2.

5.2.3 Colour designation

Table 1 gives the colour designation for each size of Type 1 instrument. These colours are used on the handle or shank and specify the size identification of the working part. Colours of sizes not included in Table 1 are at the discretion of the manufacturer.

5.2.4 Tip shape

The shape of the tip is at the discretion of the manufacturer.

5.2.5 Tip length and angle

The tip length shall be within the limits specified by the minimum and maximum angle ($l_{1min.}$ to $l_{1max.}$) as shown in Figure 1.

Table 1 — Dimensions, size designation, and colour designation for Type 1
(standard-sized instruments)

Dimensions in millimetres

Nominal size	d_1 ref.	d_2	Tolerance	d_3	Tolerance	l_2	l_3 min.	Colour designation
006	0,06	012	± 0,01	0,38	± 0,02	3	16	pink
008	0,08	014		0,40				grey
010	0,10	016		0,42				purple
015	0,15	0,21	± 0,02	0,47				white
020	0,20	0,26		0,52				yellow
025	0,25	0,31		0,57				red
030	0,30	0,36		0,62				blue
035	0,35	0,41		0,67				green
040	0,40	0,46		0,72				black
045	0,45	0,51		0,77				white
050	0,50	0,56		0,82				yellow
055	0,55	0,61		0,87				red
060	0,60	0,66		0,92				blue
070	0,70	0,76	± 0,04	1,02	± 0,04	green		
080	0,80	0,86		1,12		black		
090	0,90	0,96		1,22		white		
100	1,00	1,06		1,32		yellow		
110	1,10	1,16		1,42		red		
120	1,20	1,26		1,52		blue		
130	1,30	1,36		1,62		green		
140	1,40	1,46		1,72		black		

5.3 Type 2: taper-sized instruments

5.3.1 Length

The lengths of the working part and of the operative part shall be specified by the manufacturer, and shall be within $\pm 0,5$ mm of the specified lengths. The length l_2 shall be 3 mm. The length l_3 shall be 16 mm unless otherwise specified by the manufacturer.

Test in accordance with 7.3.

5.3.2 Tip length and angle

The tip length and angle shall be at the discretion of the manufacturer.

5.3.3 Size designation

The designated instrument size shall be presented as “xxx yy”, where “xxx” is the diameter identification (5.3.4) and “yy” is taper identification (5.3.5).

NOTE This instrument size designation is part of the 15-digit identification number defined in ISO 6360-1.

5.3.4 Diameter designation and diameters

The diameter portion of the size designation shall be d_1 (see Figure 2) expressed in hundredths of a millimetre.

Figure 2 shows the position of the diameters and lengths for all Type 2 root-canal instruments. The nominal sizes shall correspond to the values of the extended diameters at the tip of the working part in hundredths of a millimetre.

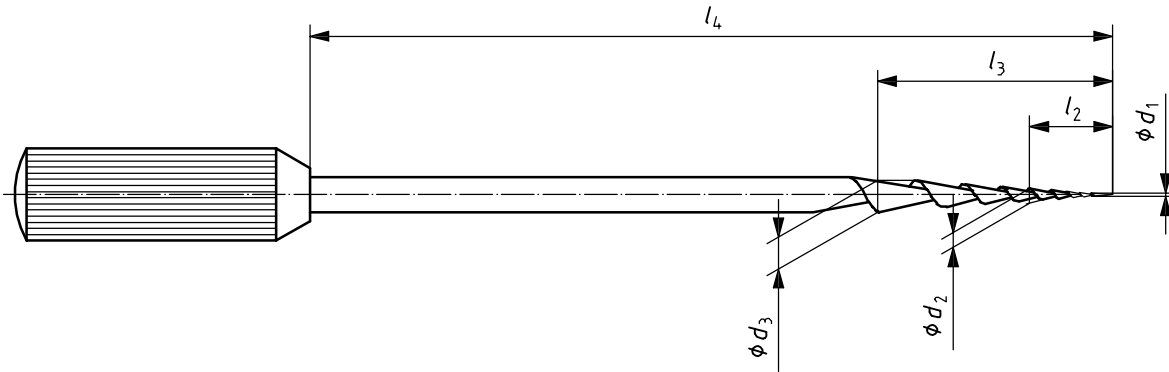

Figure 2 — Dimensions and locations for Type 2
(taper-sized instruments; taper other than 2 %)

5.3.5 Taper designation

The taper portion of the size designation shall be in percent.

NOTE 1 If the taper is 3 % (0,03 mm per millimetre of length), the taper designation is “3” or “03”.

NOTE 2 If the taper is 12 % (0,12 mm per millimetre of length), the taper designation is “12”.

5.3.6 Diameter colour identification

When colour coding is used for a brand’s set of diameter sizes, the colour sequence shall be light to dark, i.e., white, yellow, red, blue, green and black. This sequence is repeated for root-canal instruments with more than six sizes.

5.3.7 Taper colour and ring identification

When colour coding is used for a brand’s set of taper sizes, the colour sequence shall be light to dark, i.e., white, yellow, red, blue, green and black. This sequence is repeated for sets with more than six tapers.

When rings or other marks are included for a brand’s set of taper sizes, the number of rings or marks shall be in sequence starting with one for the smallest percent taper.

5.4 Type 3: shape-sized instruments

5.4.1 Length

The lengths of the working part and of the operative part shall be specified by the manufacturer, and shall be within $\pm 0,5$ mm of the specified lengths.

Test in accordance with 7.3.

5.4.2 Size designation and diameters

The size designation shall be in accordance with dimensions d_1 in Table 1 of ISO 3630-2:2000, such that d_1 is the maximum diameter of the working part. This requirement shall not preclude other sizes.

The shape of the working part is at the discretion of the manufacturer.

The arc shape type shown in Figure 3 is an example of the maximum diameter.

NOTE Figure 3 shows an example of the maximum diameter measurement d_1 .

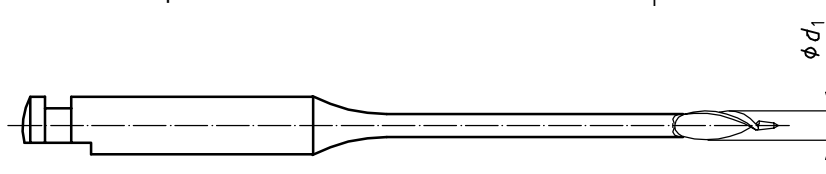

Figure 3 — Dimensions and locations for Type 3
(shape-sized instruments; arc shape)

5.4.3 Colour designation

ISO 3630-2 gives the colour designation for each size of Type 3 root-canal instrument. These colours are used on the shank and specify the size identification of the working part. Colours of sizes not included in ISO 3630-2 are at the discretion of the manufacturer.

5.5 Type 4: non-taper-sized instruments

5.5.1 Length

The lengths of the working part and of the operative part shall be specified by the manufacturer, and shall be within $\pm 0,5$ mm of the specified lengths.

Test in accordance with 7.3.

5.5.2 Size designation and diameters

Size designation and diameters follow the pattern of Table 1 but are not restricted to the sizes shown. Since the working part is cylindrical in shape, the d_1 tip diameter is the diameter of the working part.

The zero taper shape shown in Figure 4 is an example of the non-tapered diameter.

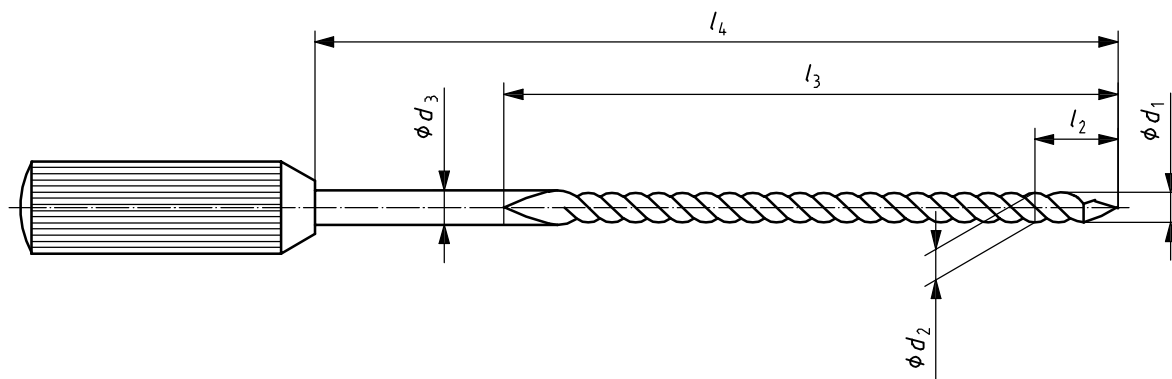

Figure 4 — Dimensions and locations for Type 4
(non-taper-sized instruments; zero taper)

5.5.3 Colour designation

Table 1 gives the colour designation for each size of Type 4. These colours are used for size identification of the working part on the handle or shank. Colours of sizes not included in Table 1 are at the discretion of the manufacturer.

5.6 Type 5: non-uniform taper-sized instruments

5.6.1 Length

The lengths of the working part and of the operative part shall be specified by the manufacturer, and shall be within $\pm 0,5$ mm of the specified lengths.

Test in accordance with 7.3.

5.6.2 Tip length and angle

The tip length and angle shall be at the discretion of the manufacturer.

5.6.3 Size designation

The designated instrument size shall be presented as “xxx yy”, where “xxx” is the diameter identification (5.6.4) and “yy” is taper identification (5.6.5).

NOTE This instrument size designation is part of the 15-digit identification number defined in ISO 6360-1.

5.6.4 Diameter designation and diameters

The diameter portion of the size designation shall be d_1 in Table 1. This requirement shall not preclude other d_1 sizes. The position of the diameters and lengths for all Type 5 root-canal instruments shall be as identified by the manufacturer.

5.6.5 Taper designation

The taper portion of the size designation shall be tenths of a percent. The taper designation shall be identified starting at the tip and sequentially to the last tapered portion as specified in 5.6.3.

NOTE 1 If the taper is 2 % (0,02 mm per millimetre of length), the taper designation is “2” or “02”.

NOTE 2 If the taper is 12 % (0,12 mm per millimetre of length), the taper designation is “12”.

NOTE 3 If the taper is considered a “half size” or portion of a whole number that number is either rounded up or down as would be appropriate in standard numeric notation.

5.6.6 Diameter colour identification

When colour coding is used for a brand's set of diameter sizes, the colour sequence shall be light to dark, i.e., white, yellow, red, blue, green and black. This sequence is repeated for root-canal instruments with more than six sizes.

5.6.7 Taper colour and ring identification

When colour coding is used for a brand's set of taper sizes, the colour sequence shall be light to dark, i.e., white, yellow, red, blue, green and black. This sequence is repeated for sets with more than six tapers. The colour shall represent the first taper of the instrument.

When rings or other marks are included for a brand's set of taper sizes, number of rings or marks shall be in sequence starting with one for the smallest percent taper. The ring or mark shall represent the first taper of the instrument.

5.7 Material

The operative part and the shank, if of one-piece, shall be made of any material and any treatment which allows the instruments to meet the requirements of this part of ISO 3630.

The handles or shanks, when provided, shall be made of metal or plastic material of a quality suitable to withstand normal operative procedures and sterilizing, if applicable. The type of material and the treatment shall be at the discretion of the manufacturer.

If the requirements of 5.9 and 5.10 are fulfilled, the root-canal instruments are considered also to comply with the requirements of 5.7.

5.8 Dimensions

5.8.1 General

The dimensions are given in millimetres.

The dimensions designated d and l shall comply with the requirements of the specific instrument's respective tables and figures. Variations in shape and design are permitted.

Test in accordance with 7.1, 7.2 and 7.3.

5.8.2 Length

The length of the operative part of the root-canal instrument shall comply with the requirements of the specific instrument's respective tables and figures.

Test in accordance with 7.1, 7.2 and 7.3.

5.8.3 Handle or shank

The provision of the handle or shank is at the discretion of the manufacturer. Shanks shall be Type 1 as specified in ISO 1797-1 or ISO 1797-2.

Instruments used with Type 1 shank as specified in ISO 1797-1 or ISO 1797-2 shall be operated with handpieces of a maximum allowed speed. Instrument manufacturers shall identify the recommended maximum revolutions per minute (rpm) for the handpiece.

5.9 Mechanical requirements

5.9.1 Resistance to fracture by twisting and angular deflection

Root-canal instruments shall comply with the requirements specified in subsequent parts of ISO 3630.

Test in accordance with 7.4.

5.9.2 Resistance to bending

Root-canal instruments shall comply with the requirements specified in subsequent parts of ISO 3630.

Test in accordance with 7.5.

5.9.3 Handle and shank security

Handles or shanks, when affixed to the operative part, shall be securely and permanently affixed. The instruments shall have no axial movement greater than 0,02 mm from the handle or shank. The instruments shall neither twist within the handle nor within the shank when the stated torque is applied.

Test in accordance with 7.6.

5.10 Chemical requirements

5.10.1 Resistance to corrosion

Root-canal instruments claimed to be corrosion resistant shall show no evidence of corrosion.

Test in accordance with 7.7.

5.10.2 Heat effects of sterilization

The working parts of the root-canal instruments shall show no signs of deterioration.

The handles shall show neither deformation nor colour change.

Test in accordance with 7.8.

6 Sampling

Use a sample of 10 root-canal instruments of each type and size for validating the following requirements:

- a) dimensions (see 5.8 and Table 1);
- b) materials (see 5.7);
- c) resistance to fracture by twisting (see 5.9.1);
- d) resistance to bending (see 5.9.2);
- e) handle and shank security (see 5.9.3);
- f) chemical requirements (see 5.10).

For other requirements sampling is specified in the respective test clauses.

7 Testing

7.1 Visual inspection

Visual inspection shall be carried out at normal visual acuity without magnification, unless otherwise specified.

7.2 Test conditions

Apparatus and root-canal instruments shall be conditioned in accordance with ISO 554 at $(23 \pm 2) ^\circ\text{C}$ for a period of at least 1 h prior to testing.

7.3 Measurement of dimensions

7.3.1 Principle

The measurement of dimensions of root-canal instruments includes lengths, diameters and tapers.

7.3.2 Apparatus

7.3.2.1 Measuring device, with an accuracy of $\pm 0,002$ mm, such as an optical comparator, shadowgraph, measuring microscope, dial gauge or other suitable device.

7.3.3 Procedure

Insert the root-canal instrument to be measured into the measuring device.

Measure the lengths l_1 , l_2 and l_3 of the root-canal instrument.

Measure the diameters d_1 and d_3 of the root-canal instrument. If the working part is less than 16 mm measure the second diameter at a distance of 1 mm from the end of the cutting portion. As an alternative to measuring the d_1 diameter, the d_2 diameter may be measured at a location 3 mm from the tip point.

The tip dimension is calculated from the projection of the taper of the working part on to a plane at the tip of the instrument (datum line) which is perpendicular to the long axis (centre-line) of that instrument.

To determine the tip length, rotate the instrument to view the position that shows that the tip approximately forms a triangle or similar geometric form as shown in Figure 1.

7.3.4 Expression of results

The taper is determined by calculation using measured diameters d_2 and d_3 . Taper is the difference between d_3 and d_2 divided by the distance between l_3 and l_2 . Taper tolerance is controlled solely by the tolerance of the specified diameters.

7.4 Resistance to fracture by twisting and angular deflection

7.4.1 Principle

The test of resistance to fracture of root-canal instruments is performed by measuring the maximum torque and angular deflection for each root-canal instrument.

7.4.2 Apparatus

7.4.2.1 Apparatus for torque test, such as shown in Figure 5 or other suitable device, consisting of the following parts.

7.4.2.1.1 Low-speed reversible geared motor, capable of revolving the test piece at 2 rpm.

7.4.2.1.2 Torque-measuring device, fixed on two linear ball-bearings mounted on the shaft of the device.

7.4.2.1.3 Chuck with jaws made of soft brass, used to clamp the test piece 3 mm from the tip and coaxial with the torque axis (see Figure 6).

7.4.2.1.4 Chuck with jaws made of hardened steel, for clamping the test piece at the shank.

7.4.2.2 Separate amplifier, for controlling the operation of the motor.

7.4.2.3 Digital display or strip chart recorder, for recording the torque and angular deflection.

7.4.2.4 Wire Cutter.

Dimensions in millimetres

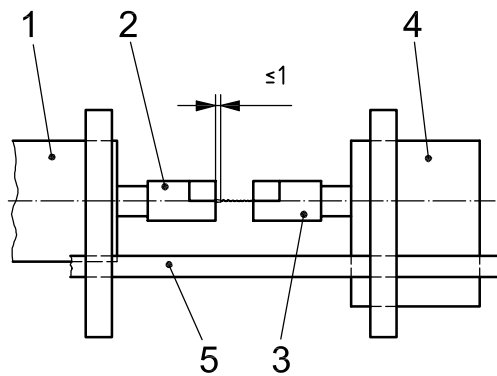

Key

- 1 reversible gear motor
- 2 chuck with hardened steel jaws
- 3 chuck with soft brass jaws
- 4 torque measuring device
- 5 linear ball-bearing

Figure 5 — Apparatus for torque test

7.4.3 Procedure

Remove the handle or shank with a suitable wire cutter at the point at which it is attached to the shaft of the root-canal instrument. Calibrate the torque-measuring device for the torque range of the sample to be tested. Set the test piece into the chuck of the geared motor leaving a maximum of 1 mm of the unground portion out of the chuck. Tighten the chuck.

Slowly slide the torque-measuring device along the linear bearing until the tip of the test piece enters 3 mm into the brass jaws. Check to ensure that the test piece is straight and centered in the jaws (see Figure 6). Tighten the chuck. Since clamping will probably induce a pre-stress in the test piece, activate the geared motor in steps until the torque digital display or the strip chart recorder shows a zero reading. After ensuring that the geared motor is set for clockwise rotation as viewed from the test piece shank end, activate the device. The device shown is designed to stop the operation when the test piece fails. Record the maximum torque and angular deflection for each instrument tested. Use caution in clamping the root-canal instrument to avoid premature failure. If damaged, replace the root-canal instrument.

Dimensions in millimetres

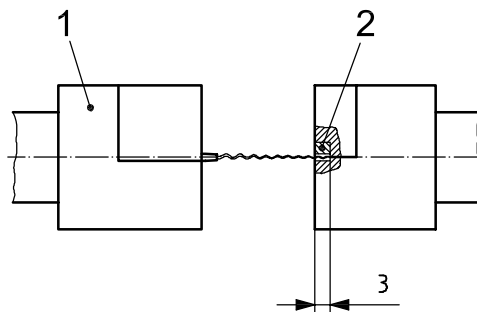

Key

- 1 chuck with hardened steel jaws
- 2 soft brass jaws

Figure 6 — Details of test chuck

7.4.4 Expression of results

The maximum torque shall be expressed in newton metres (N·m) and the angular deflection in degrees (°).

7.5 Stiffness

7.5.1 Principle

The determination of stiffness is performed by twisting the root-canal instruments through 45°.

7.5.2 Apparatus

7.5.2.1 The apparatus is as described in 7.4.2, with the modification of the clamping jaws and the bending device or catch pin as shown in Figure 7. The amplifier (7.4.2.2) shall be capable of being set to a pre-selected angular deflection of 45° at which point the test stops.

7.5.3 Procedure

Remove the handle or shank with a suitable wire cutter at the point at which the handle or shank is attached to the shaft of the root-canal instrument.

Set the apparatus to stop the angular deflection at 45°. Set the chuck on the shaft of the torque-measuring device. Set the tip of the test piece in the jaws of the chuck, perpendicular to the axis of the motor, to a depth of 3 mm. Tighten the chuck. Mount the catch pin on the motor shaft. Slide the torque-measuring device along the linear ball-bearing until the test piece is located above the catch pin. Rotate the motor in the correct direction in stages until the catch pin is lightly touching the test piece. Ensure that the display shows zero. Activate the torque-measuring device. Record the applied torque for each instrument tested.

7.5.4 Expression of results

The stiffness shall be expressed in newton metres (N·m).

Dimensions in millimetres

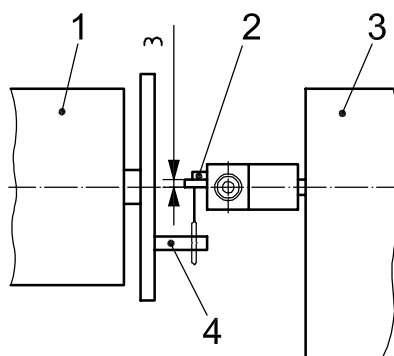

Key

- 1 reversible gear motor
- 2 stop
- 3 torque-measuring device
- 4 catch pin

Figure 7 — Apparatus for bending test

7.6 Handle and shank security

7.6.1 Principle

The determination of the handle and shank security includes tests of the axial movement and twist strength.

7.6.2 Apparatus

7.6.2.1 The apparatus is as described in 7.4.2.1 or other suitable normal laboratory device.

7.6.2.2 **Torque meter.**

7.6.3 Preparation of test sample

Take as a sample five root-canal instruments of each type and size and test them for axial movement.

Take another five root-canal instruments of each type and size and test them for twist strength.

7.6.4 Procedure

7.6.4.1 Axial movement

Measure and record the length of the operative part. Grasp the operative part and leave 3 mm of the shaft exposed. Support the handle or shank to prevent axial movement without restriction to the embedded operative part. Apply a force of 20 N axially. Measure and record the length of the operative part to determine evidence of axial movement.

NOTE Excluded from this test are paste carriers with a spiral between the working part and the shank which are designed to fracture at this point if safe torque limit is exceeded.

7.6.4.2 Twist strength

Mount the handle or shank in the chuck of a torque meter. Grip the handle or shank along a portion behind the extension of the operative part. Insert the operative portion of the instrument leaving 3 mm of the shank exposed. Twist the instrument with a torque of 35 N·m clockwise when looking down from the tip to the handle end.

Rotate the torque meter until the instrument wire slips within the handle or shank or until the minimum torque is obtained.

NOTE For wire diameters above 0,60 mm, the shaft may twist before slippage within the handle or shank.

7.6.5 Expression of results

The change of length of the operative part shall be given in millimetres.

The torque shall be given in newton metres (N·m).

7.7 Corrosion test

7.7.1 Principle

The corrosion test consists of a visual inspection for corrosion signs on the root-canal instrument after multiple sterilization cycles.

7.7.2 Reagents

7.7.2.1 **Water**, grade 2 in accordance with ISO 3696:1987.

7.7.3 Apparatus

7.7.3.1 **Autoclave**, operating at temperature and pressure conforming to the requirements in ISO 13402.

7.7.4 Preparation of test samples

Scrub 10 instruments using soap and warm water. Rinse thoroughly in water (7.7.2.1) and dry.

7.7.5 Procedure

Place 10 instruments, unwrapped, in the tray of the autoclave. After the autoclave cycle in accordance with ISO 13402, open the door, remove the tray and allow the instruments to cool to room temperature. Repeat the cycle four times for a total of five cycles exposure to steam autoclave sterilization.

7.7.6 Expression of results and compliance

Any blemish not removed by vigorous hand rubbing with a soft cloth shall be considered as evidence of corrosion.

7.8 Heat effects of sterilization

7.8.1 Principle

The test for heat effects of sterilization consists of a visual inspection for corrosion signs on the root-canal instrument after multiple sterilization cycles.

7.8.2 Reagents

7.8.2.1 **Water**, grade 2 in accordance with ISO 3696:1987.

7.8.3 Apparatus

7.8.3.1 **Autoclave**, as described in 7.7.3.1.

7.8.3.2 **Dry heat oven**, operating in accordance with ISO 13402.

7.8.4 Procedure

Excluded from the following procedure are root-canal instruments identified as “for single-use” which are delivered in a sterile state.

Autoclave 10 unwrapped root-canal instruments of each size as described in 7.7.5 for one cycle. After cooling the instruments to room temperature, place and cycle the instruments in the dry heat oven. Remove the instruments from the dry heat oven and allow them to cool to room temperature in air. Repeat the cycle four times for a total of five cycles exposure to sterilization.

Test the 10 instruments as specified in 7.1, 7.4, 7.5 and 7.6.

7.8.5 Expression of results and compliance

All sterilized root-canal instruments tested shall comply with the requirements of 5.9 in order to comply with 5.10.2.

8 Designation, marking and identification

8.1 General

Requirements for root-canal instruments are specified in subsequent parts of ISO 3630.

8.2 Identification symbols

The identification symbol, if used on the handle, on the packaging, or in manufacturer's literature, shall be in accordance with Figure 8. Symbols presented in ISO 6360-2 are allowed.

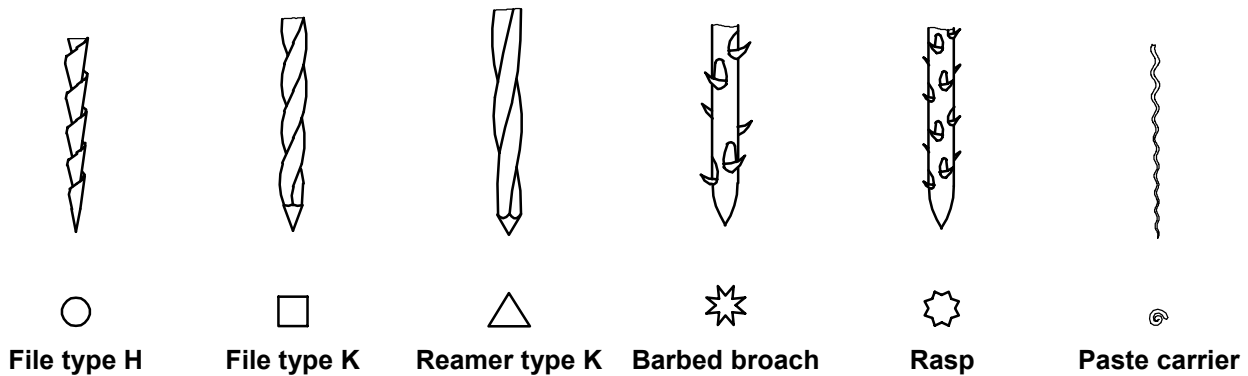

Figure 8 — Identification symbols for root-canal instruments

9 Packaging

Root-canal instruments should be packaged in unit packs of sets of instruments, which protect the contents from damage and, where sterility is claimed [see 11 j)], maintain sterility during handling, or as single instruments.

10 Manufacturer's instructions for use

Manufacturer's instructions for use shall include at least the following information:

- name and address of manufacturer or distributor;
- type of root-canal instruments;
- recommended operational use of rotary instruments;
- maximum rpm of rotary instrument, if applicable;
- recommended and/or allowable sterilizing method and disinfecting methods, if applicable;
- for instruments marked as sterile, the wording: "Sterility is not guaranteed after opening of the package", or equivalent wording.

11 Labelling

Each package of root-canal instruments shall be marked with at least the following information:

- a) name and address of manufacturer or distributor;
- b) type of instruments, product identification;
- c) length of operative part;
- d) only for Type 1 instruments: length of working part if less than 16 mm;
- e) nominal diameter and taper designation of instruments [the leading "0" digit(s) may be omitted for diameters of sizes smaller than 100];
- f) lot number (batch code);
- g) if not visible: number of instruments in unit package;
- h) material of the operative part;
- i) whether the instruments are intended for single use;
- j) when the package is sterile, marking with the symbol for "Sterile" in accordance with ISO 15223-1;
- k) when the package is marked sterile, the wording: "Sterility is not guaranteed after opening of the package", or equivalent wording;
- l) when the package is marked sterile, the expiry date expressed as year and month in accordance with ISO 8601.

Bibliography

- [1] ISO 6360-1, *Dentistry — Number coding system for rotary instruments — Part 1: General characteristics*
- [2] ISO 6360-5, *Dentistry — Number coding system for rotary instruments — Part 5: Specific characteristics of root-canal instruments*
- [3] ISO 6876, *Dental root canal sealing materials*
- [4] ISO 6877, *Dentistry — Root-canal obturating points*

ICS 11.060.20

Price based on 18 pages