**Textile glass — Chopped-strand and
continuous-filament mats — Determination
of average thickness, thickness under load
and recovery after compression**

*Verre textile — Mats à fils coupés et mats à fils continus — Détermination
de l'épaisseur moyenne, de l'épaisseur sous charge et de la recouvrance
après compression*



Reference number
ISO 3616:2001(E)

© ISO 2001

PDF disclaimer

This PDF file may contain embedded typefaces. In accordance with Adobe's licensing policy, this file may be printed or viewed but shall not be edited unless the typefaces which are embedded are licensed to and installed on the computer performing the editing. In downloading this file, parties accept therein the responsibility of not infringing Adobe's licensing policy. The ISO Central Secretariat accepts no liability in this area.

Adobe is a trademark of Adobe Systems Incorporated.

Details of the software products used to create this PDF file can be found in the General Info relative to the file; the PDF-creation parameters were optimized for printing. Every care has been taken to ensure that the file is suitable for use by ISO member bodies. In the unlikely event that a problem relating to it is found, please inform the Central Secretariat at the address given below.

© ISO 2001

All rights reserved. Unless otherwise specified, no part of this publication may be reproduced or utilized in any form or by any means, electronic or mechanical, including photocopying and microfilm, without permission in writing from either ISO at the address below or ISO's member body in the country of the requester.

ISO copyright office
Case postale 56 • CH-1211 Geneva 20
Tel. + 41 22 749 01 11
Fax + 41 22 749 09 47
E-mail copyright@iso.ch
Web www.iso.ch

Printed in Switzerland

Contents

Page

Foreword.....	iv
1 Scope	1
2 Normative references	1
3 Terms and definitions	1
4 Principle.....	2
5 Apparatus	2
6 Sampling.....	4
7 Preparation of test specimens	4
8 Conditioning of test specimens	4
9 Procedure	5
10 Calculation and expression of results.....	5
11 Test report	6

Foreword

ISO (the International Organization for Standardization) is a worldwide federation of national standards bodies (ISO member bodies). The work of preparing International Standards is normally carried out through ISO technical committees. Each member body interested in a subject for which a technical committee has been established has the right to be represented on that committee. International organizations, governmental and non-governmental, in liaison with ISO, also take part in the work. ISO collaborates closely with the International Electrotechnical Commission (IEC) on all matters of electrotechnical standardization.

International Standards are drafted in accordance with the rules given in the ISO/IEC Directives, Part 3.

Draft International Standards adopted by the technical committees are circulated to the member bodies for voting. Publication as an International Standard requires approval by at least 75 % of the member bodies casting a vote.

Attention is drawn to the possibility that some of the elements of this International Standard may be the subject of patent rights. ISO shall not be held responsible for identifying any or all such patent rights.

International Standard ISO 3616 was prepared by Technical Committee ISO/TC 61, *Plastics*, Subcommittee SC 13, *Composites and reinforcement fibres*.

This second edition cancels and replaces the first edition (ISO 3616:1977), in which the title and scope clause have been reworded to indicate clearly that the standard applies to chopped-strand and continuous-filament mats.

Textile glass — Chopped-strand and continuous-filament mats — Determination of average thickness, thickness under load and recovery after compression

1 Scope

This International Standard specifies a method for the determination of the average thickness, the thickness under load and the recovery after compression of chopped-strand and continuous-filament textile-glass mats.

2 Normative references

The following normative documents contain provisions which, through reference in this text, constitute provisions of this International Standard. For dated references, subsequent amendments to, or revisions of, any of these publications do not apply. However, parties to agreements based on this International Standard are encouraged to investigate the possibility of applying the most recent editions of the normative documents indicated below. For undated references, the latest edition of the normative document referred to applies. Members of ISO and IEC maintain registers of currently valid International Standards.

ISO 291, *Plastics — Standard atmospheres for conditioning and testing*.

ISO 1886, *Reinforcement fibres — Sampling plans applicable to received batches*.

ISO 3374, *Reinforcement products — Mats and fabrics — Determination of mass per unit area*.

3 Terms and definitions

For the purposes of this International Standard, the following terms and definitions apply.

3.1

average thickness

the thickness of a mat, in millimetres, measured in accordance with the specified method, under a specified nominal light pressure

NOTE The average thickness determined by this method does not necessarily bear a direct relation to the thickness of a single layer. The regularity of thickness of a mat must be measured on a single layer and with apparatus with a much smaller contact area than that specified in this International Standard.

3.2

thickness under load

the thickness of a mat, measured in accordance with the specified method, under a specified heavy pressure applied for a specified time, expressed as a percentage of the initial average thickness

3.3

recovery after compression

the thickness to which the mat recovers after a specified interval following removal of the specified heavy pressure, expressed as a percentage of the initial average thickness

4 Principle

The distance between the outer surfaces of a pile of superimposed layers of mats, having a total thickness of at least 5 mm, is measured under a specified light pressure. The average thickness is calculated by dividing the value obtained by the number of layers in the pile.

The distance between the outer surfaces of the pile is measured both during the application of a specified high pressure and again after a specified interval following removal of the pressure. The thickness under pressure and the recovery after compression, respectively, are calculated by dividing the two values obtained by the number of layers in the pile and expressing the results as a percentage of the average thickness.

5 Apparatus

5.1 Sharp knife.

5.2 Template for cutting out test samples, of dimensions 316 mm × 316 mm or 400 mm × 250 mm (see clause 7).

5.3 Template for cutting out test specimens, of dimensions 158 mm × 158 mm or 200 mm × 125 mm (see clause 7).

5.4 Stand, having a plane base-plate for supporting the test specimens and a suitable support for a dial-gauge micrometer (see Figure 1).

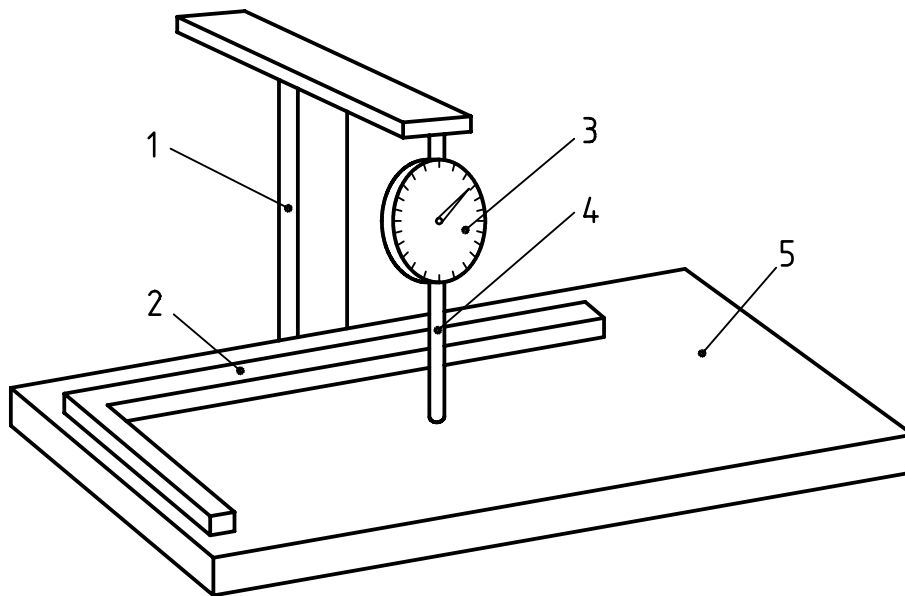

Key

- 1 Support for dial-gauge micrometer
- 2 Positioning jig
- 3 Dial-gauge micrometer
- 4 Micrometer stem
- 5 Base-plate

Figure 1 — Stand for test specimens and dial-gauge micrometer

5.5 Dial micrometer thickness gauge, graduated at 10 µm intervals and with a stem of length at least 70 mm.

5.6 Positioning jig, to ensure that the test specimens and steel plates A and B (see 5.7 and 5.8) are placed with their centres directly under the foot of the micrometer, and of such thickness that plate B rests on the mats (and not on the jig).

5.7 Polished steel plate, plate A (see Figure 2), of dimensions 158 mm × 158 mm × 1,3 mm (plate A₁) or 200 mm × 125 mm × 1,3 mm (plate A₂), having a mass of about 255 g and exerting a pressure of 100 Pa on the test specimens.¹⁾

The surfaces of the plate shall be plane and parallel.

NOTE A hydraulic system may be used in place of the plate provided that the same pressure is produced.

5.8 Polished steel plate, plate B (see Figure 3), of dimensions either 158 mm × 158 mm × 65,5 mm (plate B₁) or 200 mm × 125 mm × 65,5 mm (plate B₂), having a mass of about 12,25 kg and exerting a pressure of 5 kPa on the test specimens when used together with plate A.¹⁾ Plate B has a cut-out as shown in Figure 3.

The surfaces of the plate shall be plane and parallel.

NOTE A hydraulic system may be used in place of the plate provided that the same pressure is produced.

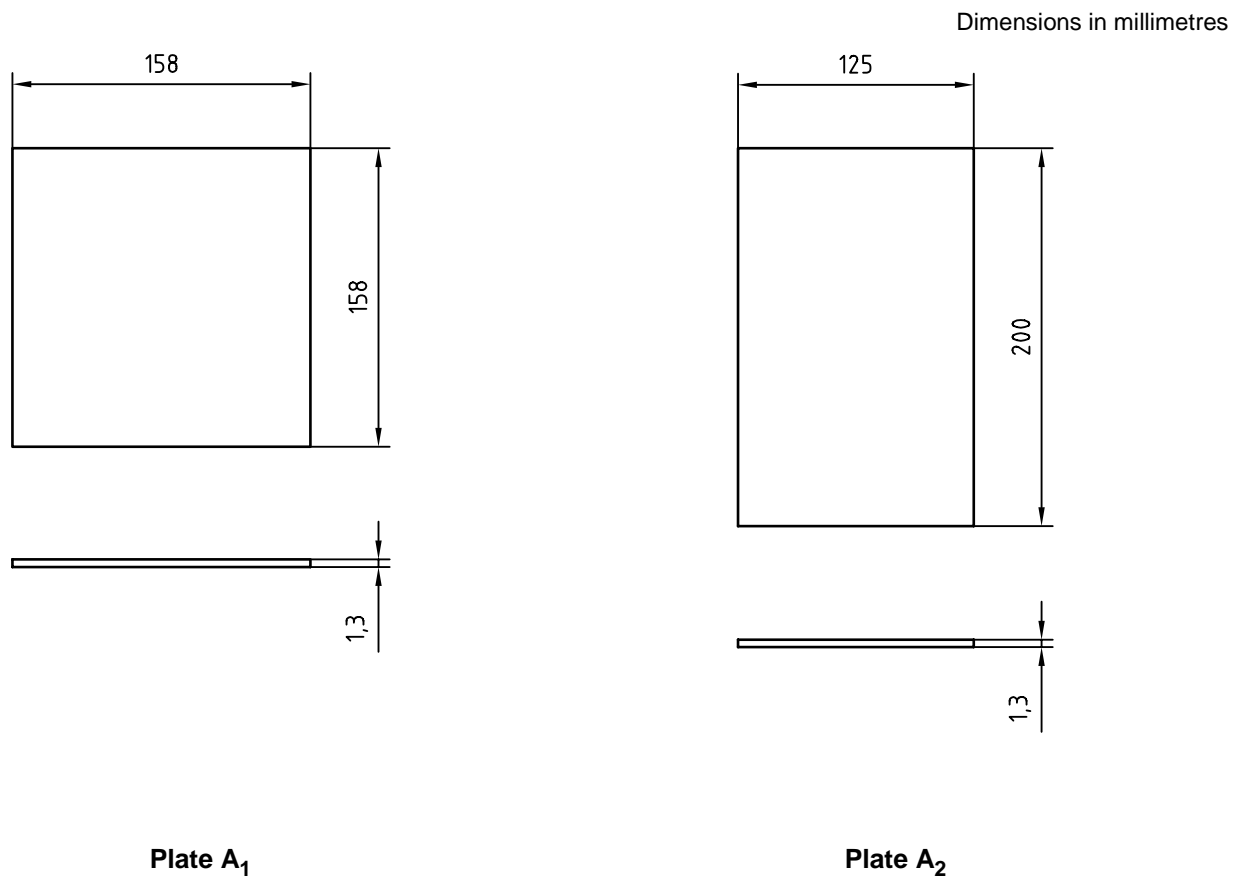
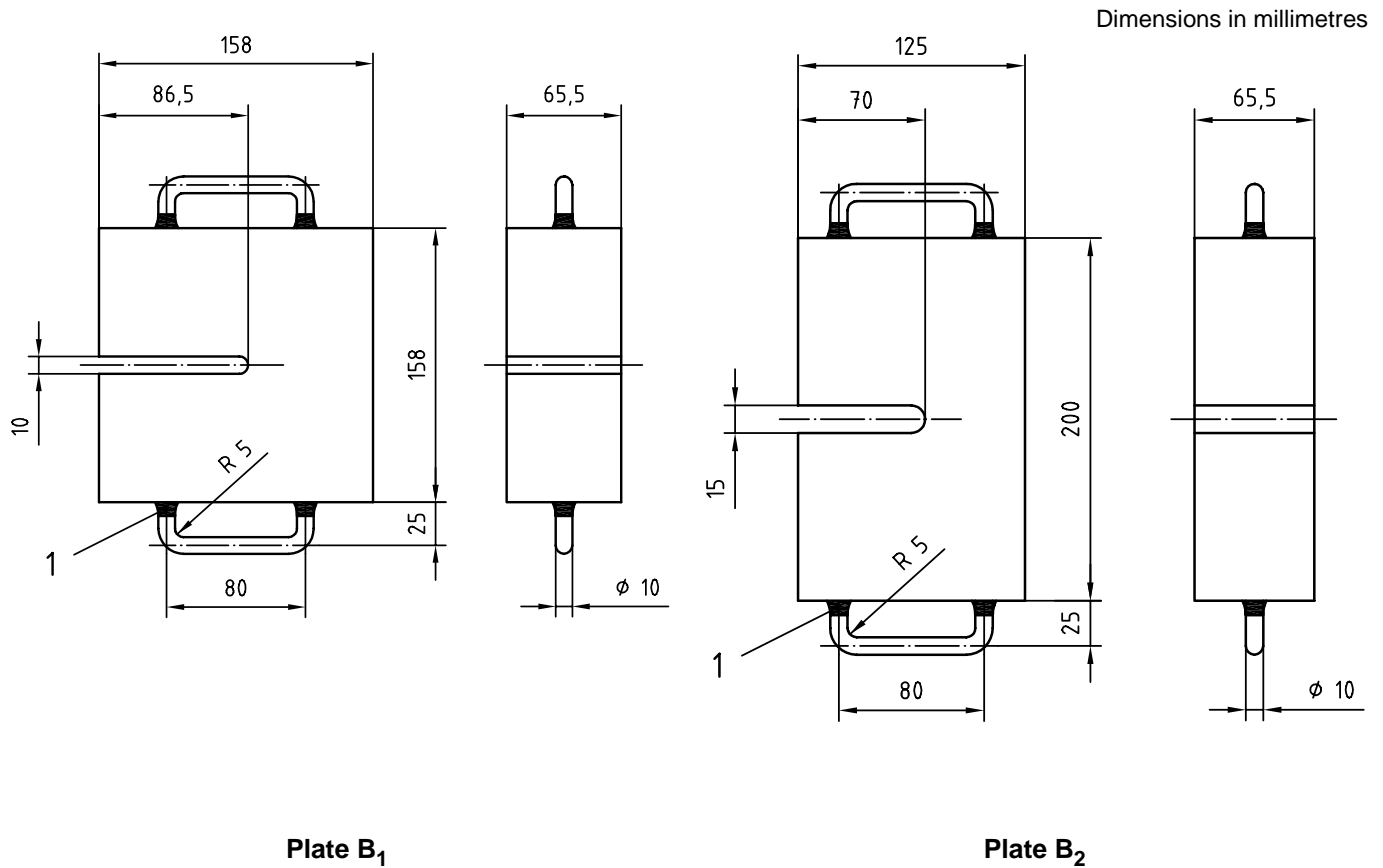

Figure 2 — Light mild-steel plate (density of steel 7,84 Mg/m³) for determination of average thickness

1) Plates A₁ and B₁ (disregarding the cut-out) each have an area of 158 mm × 158 mm and plates A₂ and B₂ (disregarding the cut-out) each have an area of 200 mm × 125 mm. Plate A is designed to exert a pressure of 100 Pa and plates A plus B a pressure of 5 kPa. Other dimensions or details of construction given in Figures 1, 2 and 3 are only given by way of example; they may be varied provided that the values for area and pressure given above are complied with.



Key

- 1 Weld

Figure 3 — Heavy mild-steel plate (density of steel 7,84 Mg/m³) for determination of thickness under load and recovery after compression

6 Sampling

Carry out sampling in accordance with the method specified in ISO 1886.

7 Preparation of test specimens

Using the template (5.2) and sharp knife (5.1), cut out three test samples, evenly distributed across the mat, of dimensions 316 mm × 316 mm or 400 mm × 250 mm, following the procedure specified in ISO 3374.

Using the template (5.3) and sharp knife, cut each test sample into four test specimens of dimensions 158 mm × 158 mm or 200 mm × 125 mm.

8 Conditioning of test specimens

Condition the test specimens for at least 16 h in one of the standard atmospheres specified in ISO 291.

The atmosphere during the test shall be the same as that used for conditioning.

9 Procedure

- 9.1** Place steel plate A (5.7) on the base-plate of the stand (5.4), under the foot of the dial-gauge micrometer (5.5). Ensure that the axis of the micrometer foot is perpendicular to plate A.
- 9.2** Record the dial-gauge reading, h_1 , in millimetres, to the nearest 0,1 mm.
- 9.3** Remove plate A.
- 9.4** Place four test specimens, cut from the same test sample, one above the other on the base-plate and with two adjacent sides contacting the positioning jig (5.6).
- 9.5** Cover them with plate A, aligning this too in the positioning jig.
- 9.6** With the micrometer foot resting on plate A, record the dial-gauge reading, h_2 , in millimetres, to the nearest 0,1 mm.
- 9.7** If $h_2 - h_1$ is less than 5 mm, cut out a further test sample and add the four new test specimens to the pile on the base-plate. Repeat steps 9.5 and 9.6 to obtain a new value for h_2 (to be used in the calculation).
- 9.8** Place steel plate B (5.8) on top of plate A, aligning it with the positioning jig.
- 9.9** Allow 10 s to elapse and then, with the micrometer foot passing through the cut-out in plate B and resting on plate A, record the new dial gauge reading, h_3 , in millimetres, to the nearest 0,1 mm.
- 9.10** Immediately after taking the reading, remove plate B.
- 9.11** Allow 20 s to elapse and then, with the micrometer foot resting on plate A, record the new dial-gauge reading, h_4 , in millimetres, to the nearest 0,1 mm.
- 9.12** Repeat steps 9.4 to 9.11 twice using new test specimens.

10 Calculation and expression of results

10.1 Notation

In the calculations which follow:

- h_1 is the dial-gauge reading, in millimetres, with the micrometer foot resting on plate A only;
- h_2 is the dial-gauge reading, in millimetres, with the micrometer foot resting on plate A, with the test specimens in position;
- h_3 is the dial-gauge reading, in millimetres, with the micrometer foot resting on plate A and with the test specimens and plate B in position;
- h_4 is the dial-gauge reading, in millimetres, with the micrometer foot resting on plate A and with the test specimens in position after removal of plate B;
- n is the number of the test specimens in the pile (4 or a multiple of 4).

10.2 Average thickness

The average thickness, in millimetres, is given by the formula:

$$\frac{h_2 - h_1}{n}$$

Express the result to three significant figures.

10.3 Thickness under load

The thickness under load is given, as a percentage of the average thickness, by the formula:

$$\frac{h_3 - h_1}{h_2 - h_1} \times 100$$

Express the result to two significant figures.

10.4 Recovery after compression

The recovery after compression is given, as a percentage of the average thickness, by the formula:

$$\frac{h_4 - h_1}{h_2 - h_1} \times 100$$

Express the result to two significant figures.

11 Test report

The test report shall include the following particulars:

- a) a reference to this International Standard;
- b) all details necessary for complete identification of the material tested;
- c) the dimensions of the test specimens used;
- d) the number of test specimens in the pile (4 or a multiple of 4);
- e) the conditioning and testing atmosphere;
- f) details of the hydraulic system if used (see note to 5.7 and 5.8);
- g) the average value of the average thickness, obtained as indicated in 10.2;
- h) the average value of the thickness under load, obtained as indicated in 10.3;
- i) the average value of the percentage recovery after compression, obtained as indicated in 10.4;
- j) any circumstances that might have influenced the results;
- k) the date of the test.

ICS 59.100.10

Price based on 6 pages

© ISO 2001 – All rights reserved