Fluid power systems — O-rings —
Part 4:
Anti-extrusion rings (back-up rings)

Transmissions hydrauliques et pneumatiques — Joints toriques —
Partie 4: Bagues anti-extrusion



Reference number
ISO 3601-4:2008(E)

© ISO 2008

PDF disclaimer

This PDF file may contain embedded typefaces. In accordance with Adobe's licensing policy, this file may be printed or viewed but shall not be edited unless the typefaces which are embedded are licensed to and installed on the computer performing the editing. In downloading this file, parties accept therein the responsibility of not infringing Adobe's licensing policy. The ISO Central Secretariat accepts no liability in this area.

Adobe is a trademark of Adobe Systems Incorporated.

Details of the software products used to create this PDF file can be found in the General Info relative to the file; the PDF-creation parameters were optimized for printing. Every care has been taken to ensure that the file is suitable for use by ISO member bodies. In the unlikely event that a problem relating to it is found, please inform the Central Secretariat at the address given below.



COPYRIGHT PROTECTED DOCUMENT

© ISO 2008

All rights reserved. Unless otherwise specified, no part of this publication may be reproduced or utilized in any form or by any means, electronic or mechanical, including photocopying and microfilm, without permission in writing from either ISO at the address below or ISO's member body in the country of the requester.

ISO copyright office
Case postale 56 • CH-1211 Geneva 20
Tel. + 41 22 749 01 11
Fax + 41 22 749 09 47
E-mail copyright@iso.org
Web www.iso.org

Published in Switzerland

Contents

Page

Foreword.....	iv
Introduction	v
1 Scope	1
2 Normative references	1
3 Terms and definitions	1
4 Symbols	2
5 General requirements related to O-ring housings	2
6 Types of anti-extrusion (back-up) rings	3
6.1 Spiral type, T1	3
6.2 Angle cut type, T2.....	5
6.3 Solid type, T3.....	5
6.4 Angle cut concave type, T4	6
6.5 Solid concave type, T5	7
7 Positioning of anti-extrusion rings in housings.....	8
8 Anti-extrusion ring designation code and materials.....	8
8.1 Designation code	8
8.2 Materials	9
9 Dimensions and tolerances	9
9.1 Axial and radial widths of anti-extrusion rings.....	9
9.2 Outside diameters of anti-extrusion rings for piston sealing applications	10
9.3 Inside diameters of anti-extrusion rings for rod sealing applications	11
10 Identification statement (reference to this part of ISO 3601)	11

Foreword

ISO (the International Organization for Standardization) is a worldwide federation of national standards bodies (ISO member bodies). The work of preparing International Standards is normally carried out through ISO technical committees. Each member body interested in a subject for which a technical committee has been established has the right to be represented on that committee. International organizations, governmental and non-governmental, in liaison with ISO, also take part in the work. ISO collaborates closely with the International Electrotechnical Commission (IEC) on all matters of electrotechnical standardization.

International Standards are drafted in accordance with the rules given in the ISO/IEC Directives, Part 2.

The main task of technical committees is to prepare International Standards. Draft International Standards adopted by the technical committees are circulated to the member bodies for voting. Publication as an International Standard requires approval by at least 75 % of the member bodies casting a vote.

Attention is drawn to the possibility that some of the elements of this document may be the subject of patent rights. ISO shall not be held responsible for identifying any or all such patent rights.

ISO 3601-4 was prepared by Technical Committee ISO/TC 131, *Fluid power systems*, Subcommittee SC 7, *Sealing devices*.

ISO 3601 consists of the following parts, under the general title *Fluid power systems — O-rings*:

- *Part 1: Inside diameters, cross-sections, tolerances and designation codes*
- *Part 2: Housing dimensions for general applications*
- *Part 3: Quality acceptance criteria*
- *Part 4: Anti-extrusion rings (back-up rings)*
- *Part 5: Suitability of elastomeric materials for industrial applications*

Introduction

In fluid power systems, power is transmitted and controlled through a fluid (liquid or gas) under pressure within an enclosed circuit. Where high pressures are encountered, it is recommended that an anti-extrusion ring (back-up ring) be incorporated within the O-ring housing to limit extrusion of the O-ring between the metal parts (e.g. cylinder bore and piston or rod and housing).

Fluid power systems — O-rings —

Part 4: Anti-extrusion rings (back-up rings)

1 Scope

This part of ISO 3601 specifies dimensions and tolerances for five types of anti-extrusion rings, which are also known as back-up rings:

- a) spiral type (T1);
- b) angle cut type (T2);
- c) solid type (T3);
- d) angle cut concave type (T4);
- e) solid concave type (T5).

These anti-extrusion rings are for use with selected O-ring sizes as specified in ISO 3601-1 and the relevant housing dimensions specified in ISO 3601-2.

2 Normative references

The following referenced documents are indispensable for the application of this document. For dated references, only the edition cited applies. For undated references, the latest edition of the referenced document (including any amendments) applies.

ISO 3601-1¹⁾, *Fluid power systems — O-rings — Part 1: Inside diameters, cross-sections, tolerances and designation codes*

ISO 3601-2:2008, *Fluid power systems — O-rings — Part 2: Housing dimensions for general applications*

ISO 5598, *Fluid power systems and components — Vocabulary*

3 Terms and definitions

For the purposes of this document, the terms and definitions given in ISO 5598 apply.

1) To be published. (Revision of ISO 3601-1:2002)

4 Symbols

The following letter symbols are used in this part of ISO 3601:

b_1	width of O-ring housing without anti-extrusion ring
b_2	width of O-ring housing with one anti-extrusion ring
b_3	width of O-ring housing with two anti-extrusion rings
b_5	width of single anti-extrusion ring, angle cut types T2 and T4, and solid types T3 and T5
b_6	width of anti-extrusion ring, spiral type T1
b_7	total width ($b_5 + h$) at apex of single anti-extrusion ring, angle cut concave type T4 and solid concave type T5
d_2	O-ring cross-section diameter
d_3	housing diameter for piston seal housings
d_4	bore diameter for piston application
d_5	rod diameter
d_6	housing diameter for rod seal housings
d_9	piston diameter
d_{10}	bore diameter for rod application
d_{14}	internal diameter of anti-extrusion ring (spiral type T1 only)
d_{15}	external diameter of anti-extrusion ring (spiral type T1 only)
d_{16}	inside diameter of anti-extrusion ring (angle cut types T2 and T4, or solid types T3 and T5)
d_{17}	outside diameter of anti-extrusion ring (angle cut types T2 and T4, or solid types T3 and T5)
h	extension of concave anti-extrusion ring beyond b_5 base width
l	gap of anti-extrusion ring, spiral type T1, on mandrel diameter d_{14}
R	radius of cavity in concave anti-extrusion ring
t	radial section of anti-extrusion ring

5 General requirements related to O-ring housings

For general requirements of O-ring housings, such as surface roughness, corners and edges of undefined shape, lead-in chamfers, housing diameter tolerances and housing widths, see the related clauses in ISO 3601-2.

6 Types of anti-extrusion (back-up) rings

6.1 Spiral type, T1

6.1.1 The spiral type, T1, anti-extrusion ring (see Figure 1) is typically associated with applications in which the system pressure is between 10 MPa (100 bar) and 20 MPa (200 bar). Continuous rings, such as the angle cut type (T2) or the solid type (T3), are preferred for use at pressures higher than 20 MPa (200 bar), but assembly problems can be encountered with closed housings or at small diameters.

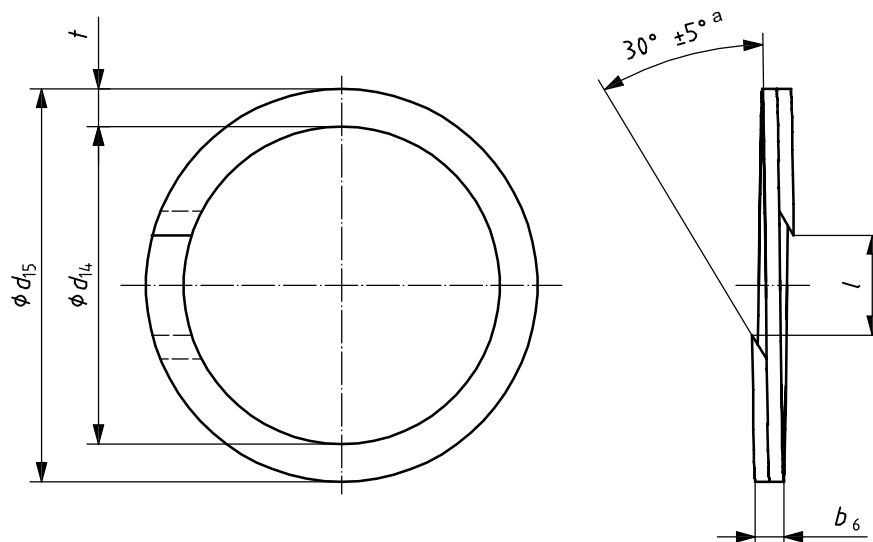

^a This angle may be increased to $45^\circ \pm 5^\circ$ when d_{14} is less than 7,0 mm.

NOTE Direction of the spiral is optional.

Figure 1 — Spiral type (T1) anti-extrusion ring

6.1.2 At higher temperatures, typically in excess of 100 °C, anti-extrusion rings can be necessary even when pressures are less than 10 MPa (100 bar). Independent of temperature and pressure, special operating conditions can also require the use of anti-extrusion rings. These operating conditions should be discussed with the seal supplier at the design stage.

6.1.3 Dimensions shall conform to the requirements given in Table 1.

Table 1 — Dimensions of gap, l , of spiral type (T1) anti-extrusion rings in relation to mandrel diameter, d_{14}

Dimensions in millimetres

O-ring nominal cross-section d_2	Mandrel diameter d_{14}	Gap l
1,78	$d_{14} \leq 10$	$1,2 \pm 0,4$
	$10 < d_{14} \leq 20$	$1,4 \pm 0,6$
	$20 < d_{14} \leq 60$	$1,8 \pm 0,6$
	$d_{14} > 60$	$3 \pm 1,5$
2,62	$d_{14} \leq 20$	$1,2 \pm 0,4$
	$20 < d_{14} \leq 39$	$1,8 \pm 0,6$
	$39 < d_{14} \leq 170$	$3 \pm 1,5$
	$d_{14} > 170$	$4,4 \pm 2$
3,53	$d_{14} \leq 19$	$1,2 \pm 0,4$
	$19 < d_{14} \leq 39$	$1,4 \pm 0,6$
	$39 < d_{14} \leq 76$	$3,2 \pm 1,6$
	$76 < d_{14} \leq 114$	$4,4 \pm 2$
	$114 < d_{14} \leq 393$	$6,4 \pm 1,6$
	$d_{14} > 393$	$6,4 \pm 2$
5,33	$d_{14} \leq 26$	$1,8 \pm 0,6$
	$26 < d_{14} \leq 35$	$3 \pm 1,5$
	$35 < d_{14} \leq 60$	$3,2 \pm 1,6$
	$60 < d_{14} \leq 280$	$4,4 \pm 2$
	$d_{14} > 280$	$6,4 \pm 2$
6,99	$d_{14} > 100$	$6,4 \pm 2$

6.2 Angle cut type, T2

The angle cut type, T2, anti-extrusion ring (see Figure 2) is the most widely used, mainly because it is easier to install than the solid type, T3, and affords better protection of the O-ring when the system pressure ranges from 15 MPa (150 bar) to greater than 20 MPa (200 bar).

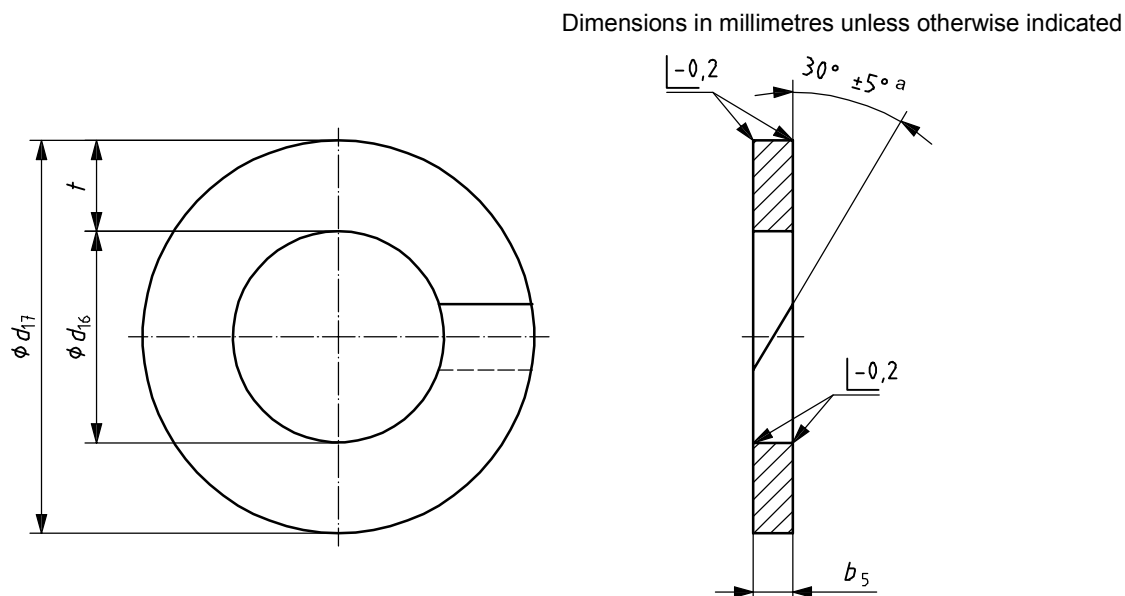

^a This angle may be increased to $45^\circ \pm 5^\circ$ when d_{16} is less than 10,0 mm.

NOTE Direction of the angle cut is optional.

Figure 2 — Angle cut type (T2) anti-extrusion ring

6.3 Solid type, T3

The solid type, T3, anti-extrusion ring (see Figure 3), while difficult to install in O-ring housings that have small diameters or are closed, affords the ultimate protection of the O-ring at all pressures and temperatures. It is the preferred type for system pressures greater than 25 MPa (250 bar) and temperatures higher than 135 °C.

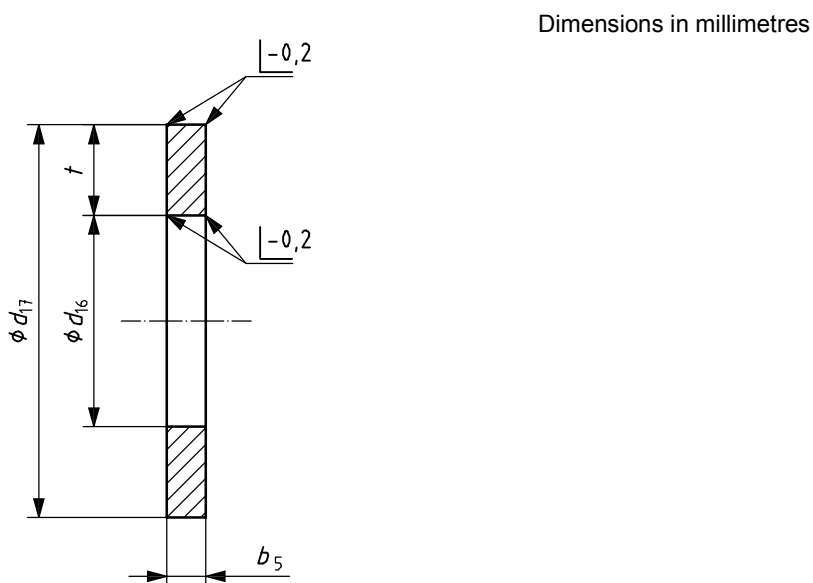

Figure 3 — Solid type (T3) anti-extrusion ring

6.4 Angle cut concave type, T4

The angle cut concave type, T4, anti-extrusion ring (see Figure 4) is similar to the angle cut type, T2, but is designed to accommodate the O-ring and retain its shape better under high pressure.

CAUTION — This type of anti-extrusion ring is not recommended for automatic assembly.

Dimensions in millimetres

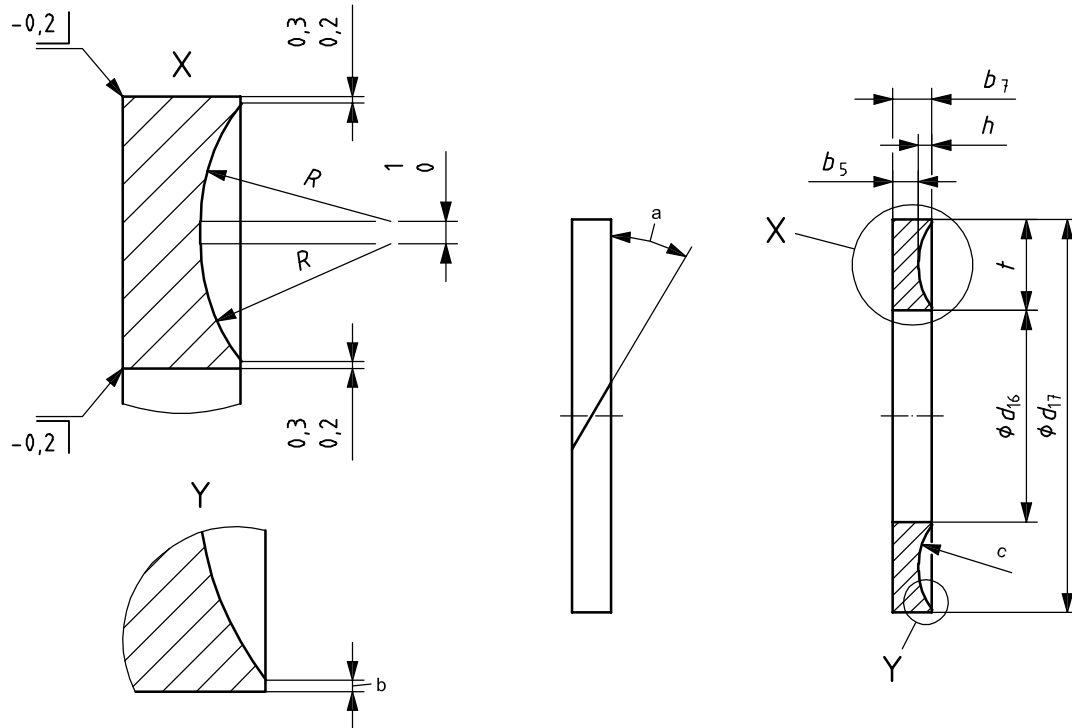

- a Angle is normally $30^\circ \pm 5^\circ$ but may be increased to $45^\circ \pm 5^\circ$ when d_{16} is less than 10,0 mm.
- b This area shall be free of burrs.
- c The O-ring is always positioned against the concave side of the anti-extrusion ring.

NOTE Direction of the angle cut is optional.

Figure 4 — Angle cut concave type (T4) anti-extrusion ring

6.5 Solid concave type, T5

The solid concave type, T5, anti-extrusion ring (see Figure 5) is similar to the solid type, T3, but is designed to accommodate the O-ring and retain its shape better under high pressure.

CAUTION — This type of anti-extrusion ring is not recommended for automatic assembly.

Dimensions in millimetres

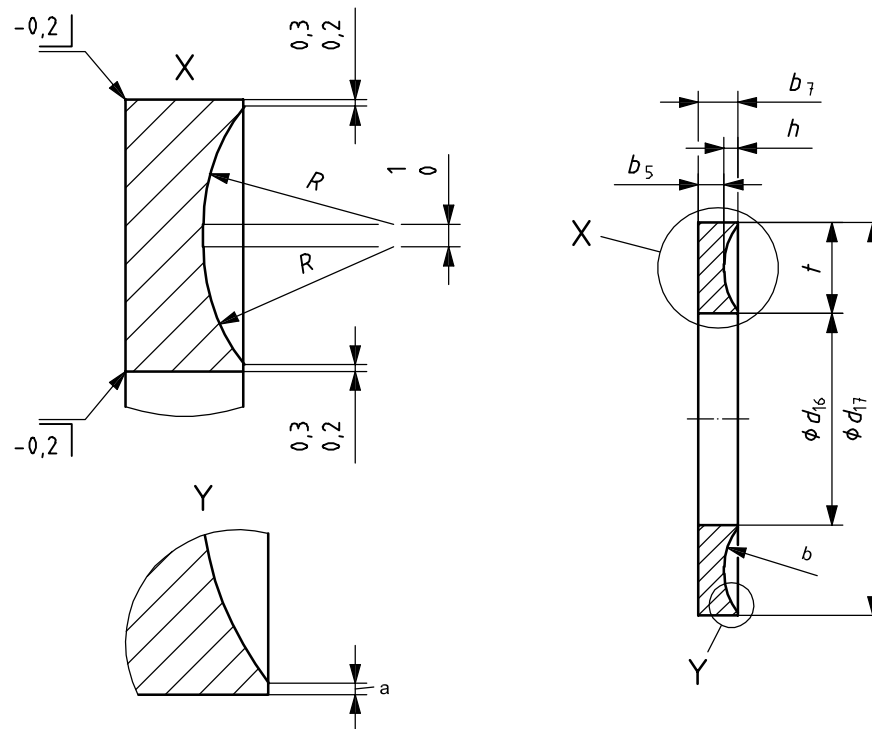

- a This area shall be free of burrs.
- b The O-ring is always positioned against the concave side of the anti-extrusion ring.

Figure 5 — Solid concave type (T5) anti-extrusion ring

7 Positioning of anti-extrusion rings in housings

Positioning of anti-extrusion rings depends on the application and the direction in which pressure acts on the O-ring housing. Anti-extrusion rings shall be positioned in accordance with Figures 6 and 7.

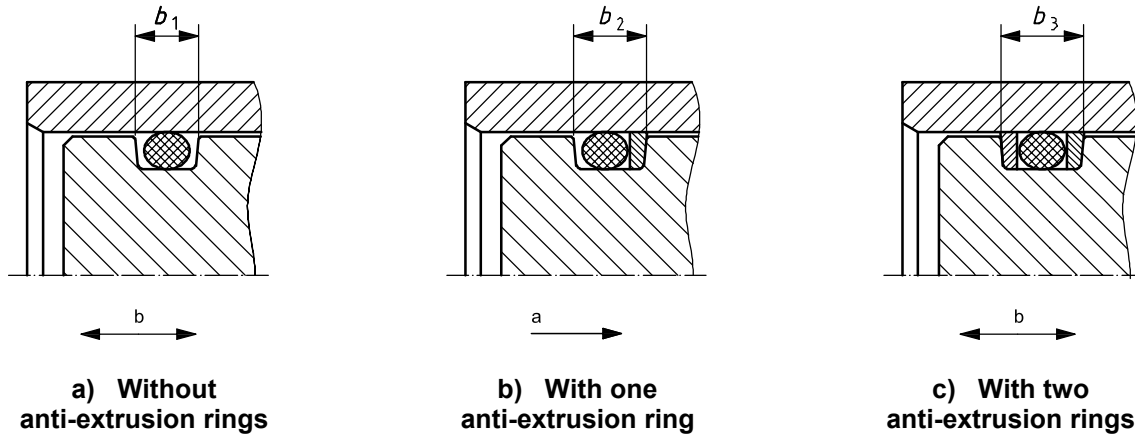

- a Pressure acting in one direction.
- b Pressure acting in alternating directions.

Figure 6 — Positioning of anti-extrusion rings in a piston sealing application

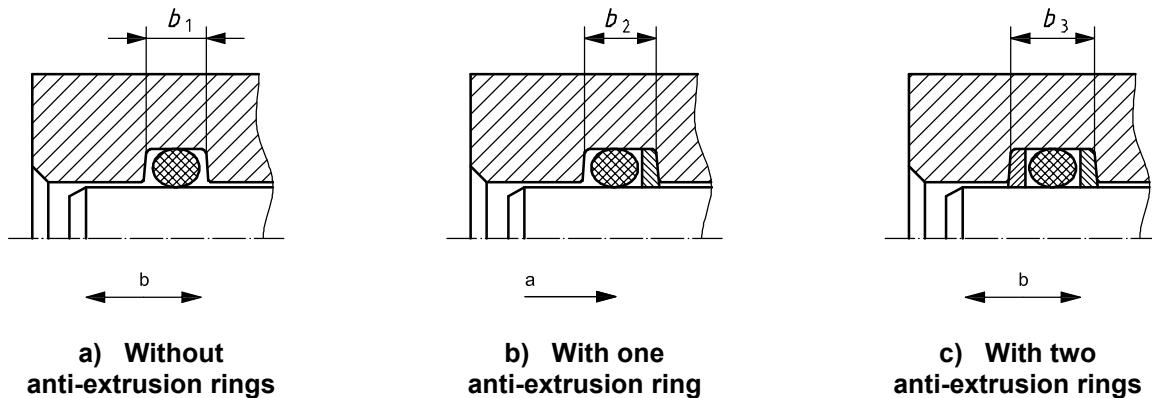

- a Pressure acting in one direction.
- b Pressure acting in alternating directions.

Figure 7 — Positioning of anti-extrusion rings in a rod sealing application

8 Anti-extrusion ring designation code and materials

8.1 Designation code

Anti-extrusion rings that conform to this part of ISO 3601 can be designated by either a custom designation agreed between the user and manufacturer or the designation code described as follows:

- a) the words “Anti-extrusion ring” followed by a space;
- b) “ISO 3601-4” followed by a hyphen;
- c) the type of anti-extrusion ring (T1 for spiral type; T2 for angle cut type; T3 for solid type; T4 for angle cut concave type; or T5 for solid concave type), followed by a hyphen;

- d) three digits to indicate the cross-section, d_2 , of the O-ring in millimetres (for example, if $d_2 = 6,99$ mm, the three digits would be 699), followed by a hyphen;
- e) the application type, that is, PD for piston dynamic, PS for piston static, RD for rod dynamic, or RS for rod static, followed by a hyphen;
- f) six digits to indicate the anti-extrusion ring's working diameter in millimetres, that is, the inside diameter (d_{14} or d_{16}) for rod applications or the outside diameter (d_{15} or d_{17}) for piston applications (for example, a working diameter of 200,00 mm would be designated as 020000), followed by a hyphen;
- g) six digits to indicate the housing diameter, d_3 , for piston seal housings or d_6 for rod seal housings, in millimetres (for example, a housing diameter of 211,8 mm would be designated as 021180).

EXAMPLE An anti-extrusion ring of the spiral type for use with an O-ring with a cross-section of 6,99 mm, in a rod dynamic application with a working diameter of 200,00 mm for use in a housing of diameter 211,8 mm would be designated as

Anti-extrusion ring ISO 3601-4-T1-699-RD-020000-021180

8.2 Materials

8.2.1 The most popular material for anti-extrusion rings is unfilled polytetrafluoroethylene (PTFE). Because this material is very soft compared to other plastics, it closes the extrusion gap under pressure and protects the O-ring against extrusion into the gap between the metal parts. For some applications, a portion of other materials may be added to the PTFE for additional strength. These materials are mainly glass (typically 15 % of the material mass), carbon (typically 10 % to 15 %) or bronze (typically 40 % to 60 %). Other filler materials may be used.

8.2.2 Polyamide (PA) material, both unfilled (virgin) and filled, is also used for anti-extrusion rings. This material shows good properties for this type of application under some operating conditions.

8.2.3 Other materials, such as hard block/soft block thermoplastics and polyurethane, may also be used as long as they serve the purpose of preventing the O-ring from extruding into the gap between the metal parts under operating conditions.

Users should consult the supplier for recommendations for the most suitable material that satisfies their individual requirements in specific applications.

9 Dimensions and tolerances

9.1 Axial and radial widths of anti-extrusion rings

9.1.1 Axial widths

Dimensions and tolerances for axial widths b_5 or b_6 of anti-extrusion rings, in relation to the cross-sections of the O-rings with which they are to be used, shall be in accordance with Table 2. The concave anti-extrusion rings have not only an axial width, b_5 , but also other dimensions that define their geometry; these dimensions and their appropriate tolerances shall be in accordance with Table 2.

Table 2 — Dimensions and tolerances for anti-extrusion rings for ISO 3601-1 O-rings

Dimensions in millimetres

Anti-extrusion ring dimensions	O-ring cross-section				
	d_2				
	1,78	2,62	3,53	5,33	6,99
b_5, b_6	$1,4 \pm 0,1$	$1,4 \pm 0,1$	$1,4 \pm 0,1$	$1,8 \pm 0,1$	$2,6 \pm 0,1$
b_7	$1,7 \pm 0,1$	$1,8 \pm 0,1$	$2,0 \pm 0,1$	$2,8 \pm 0,1$	$4,1 \pm 0,1$
h	0,3	0,4	0,6	1,1	1,6
R	1,2	1,6	2,0	3,0	4,0

9.1.2 Radial widths

9.1.2.1 General

The radial widths of anti-extrusion rings depend on the radial depths of the housings, and these depend on the application, for example dynamic hydraulic or static hydraulic. For normal pneumatic applications, it is not necessary to use anti-extrusion rings with O-rings.

9.1.2.2 Piston sealing

For piston sealing, the radial depths of the housings shall be calculated by subtracting the nominal values of the piston housing diameter, d_3 , from the bore diameter, d_4 . Values for these dimensions are given in ISO 3601-2:2008, Tables 2 and 3.

9.1.2.3 Rod sealing

For rod sealing, the radial depth of the housings shall be calculated by subtracting the nominal values of the rod diameter, d_5 , from the rod housing diameter, d_6 . Values for these dimensions are given in ISO 3601-2:2008, Tables 4 and 5.

9.1.2.4 Tolerance

The tolerance for the radial width, t , of the anti-extrusion rings shall be ${}^0_{-0,1}$ mm.

9.2 Outside diameters of anti-extrusion rings for piston sealing applications

9.2.1 General

For anti-extrusion rings used in piston sealing applications, the outside diameters d_{15} and d_{17} shall be taken from the nominal values of d_4 . Values for these dimensions are given in ISO 3601-2:2008, Tables 2 and 3.

9.2.2 Tolerances for spiral type (T1) anti-extrusion rings used in piston sealing applications

Because a tolerance cannot be given for diameter d_{15} on spiral type (T1) anti-extrusion rings, only a tolerance of ${}^0_{-0,1}$ mm on the radial width applies.

9.2.3 Tolerances for angle cut type (T2 and T4) anti-extrusion rings used in piston sealing applications

Tolerances for the outside diameter, d_{17} , for angle cut (T2) anti-extrusion rings used with ISO 3601-1 O-rings shall be taken from the values given in Table 3. These tolerances apply before the ring is cut.

Table 3 — Tolerances on dimension d_{17} of angle cut type (T2 and T4) anti-extrusion rings for use with ISO 3601-1 O-rings

Dimensions in millimetres

Bore diameter for piston application, d_4	≤ 50	> 50 ≤ 120	> 120 ≤ 180	> 180 ≤ 250	> 250 ≤ 310	> 310 ≤ 400	> 400 ≤ 500	> 500 ≤ 600	> 600 ≤ 700
Tolerance on dimension d_{17}	+ 0,05 - 0,10	+ 0,08 - 0,16	+ 0,10 - 0,20	+ 0,13 - 0,26	+ 0,15 - 0,30	+ 0,22 - 0,44	+ 0,30 - 0,60	+ 0,38 - 0,76	+ 0,48 - 0,96

9.3 Inside diameters of anti-extrusion rings for rod sealing applications

9.3.1 General

For anti-extrusion rings used in rod sealing applications, inside diameters d_{14} and d_{16} shall be taken from the nominal values of d_5 . Values for these dimensions are given in ISO 3601-2:2008, Tables 4 and 5.

9.3.2 Tolerances for spiral type (T1) anti-extrusion rings used in rod sealing applications

Because a tolerance cannot be given for diameter d_{14} on spiral type (T1) anti-extrusion rings, only a tolerance of $\begin{smallmatrix} 0 \\ -0,1 \end{smallmatrix}$ mm on the radial width applies.

9.3.3 Tolerances for angle cut type (T2 and T4) and solid type (T3 and T5) anti-extrusion rings used in rod sealing applications

Tolerances for the inside diameter, d_{16} , of angle cut type (T2 and T4) and solid type (T3 and T5) anti-extrusion rings used with ISO 3601-1 O-rings shall be taken from the values given in Table 4. These tolerances apply before the ring is cut.

Table 4 — Tolerances on dimension d_{16} of angle cut type (T2 and T4) and solid type (T3 and T5) anti-extrusion rings for use with ISO 3601-1 O-rings

Dimensions in millimetres

Bore diameter for rod application, d_4	≤ 50	> 50 ≤ 120	> 120 ≤ 180	> 180 ≤ 250	> 250 ≤ 310	> 310 ≤ 400	> 400 ≤ 500	> 500 ≤ 600	> 600 ≤ 700
Tolerance on dimension d_{16}	+ 0,10 - 0,05	+ 0,16 - 0,08	+ 0,20 - 0,10	+ 0,26 - 0,13	+ 0,30 - 0,15	+ 0,44 - 0,22	+ 0,60 - 0,30	+ 0,76 - 0,38	+ 0,96 - 0,48

10 Identification statement (reference to this part of ISO 3601)

Manufacturers are strongly recommended to use the following statement in test reports, catalogues and sales literature when electing to comply with this part of ISO 3601:

“Anti-extrusion rings (back-up rings) in accordance with ISO 3601-4:2008, *Fluid power systems — O-rings — Part 4: Anti-extrusion rings (back-up rings)*.”

ICS 23.100.60; 83.140.50

Price based on 11 pages