Fluid power systems — O-rings —
Part 2:
Housing dimensions for general
applications

Transmissions hydrauliques et pneumatiques — Joints toriques —
Partie 2: Dimensions des logements pour applications générales



Reference number
ISO 3601-2:2008(E)

PDF disclaimer

This PDF file may contain embedded typefaces. In accordance with Adobe's licensing policy, this file may be printed or viewed but shall not be edited unless the typefaces which are embedded are licensed to and installed on the computer performing the editing. In downloading this file, parties accept therein the responsibility of not infringing Adobe's licensing policy. The ISO Central Secretariat accepts no liability in this area.

Adobe is a trademark of Adobe Systems Incorporated.

Details of the software products used to create this PDF file can be found in the General Info relative to the file; the PDF-creation parameters were optimized for printing. Every care has been taken to ensure that the file is suitable for use by ISO member bodies. In the unlikely event that a problem relating to it is found, please inform the Central Secretariat at the address given below.



COPYRIGHT PROTECTED DOCUMENT

© ISO 2008

All rights reserved. Unless otherwise specified, no part of this publication may be reproduced or utilized in any form or by any means, electronic or mechanical, including photocopying and microfilm, without permission in writing from either ISO at the address below or ISO's member body in the country of the requester.

ISO copyright office
Case postale 56 • CH-1211 Geneva 20
Tel. + 41 22 749 01 11
Fax + 41 22 749 09 47
E-mail copyright@iso.org
Web www.iso.org

Published in Switzerland

Contents

Page

Foreword.....	iv
Introduction	v
1 Scope	1
2 Normative references	1
3 Terms and definitions.....	1
4 Symbols	2
5 O-ring housings	3
5.1 Typical O-ring applications.....	3
5.2 Surface roughness	6
5.3 Housing dimensions.....	6
5.4 Corners and edges of undefined shape	8
5.5 Lead-in chamfer	9
5.6 Calculation of housing dimensions for radial sealing applications.....	9
6 Requirements	13
6.1 Housing dimensions.....	13
6.2 Determining O-ring size for custom housing dimensions	14
6.3 Gland fill consideration in design of housings	14
6.4 Temperature consideration in design of housings	14
7 Identification statement.....	14
Annex A (informative) Correlation of ISO 3601-1 aerospace O-ring size identification code with EN 3748 O-ring housing codes	37
Annex B (informative) How to determine the proper O-ring size for custom housings used for radial and axial applications	38
Bibliography	44

Introduction

In fluid power systems, power is transmitted and controlled through a fluid (liquid or gas) under pressure within an enclosed circuit. To avoid leakage or to seal different chambers of a component from each other sealing devices are used. O-rings are one type of sealing devices. To seal properly, an O-ring has to be used in an appropriate housing for the application.

Annexes A and B of this part of ISO 3601 are for information only.

Fluid power systems — O-rings —

Part 2: Housing dimensions for general applications

1 Scope

This part of ISO 3601 specifies the housing (gland) dimensions for class A O-rings for general industrial applications conforming to ISO 3601-1, as well as housing dimensions for class B O-rings used on selected metric-dimensioned hardware, e.g. fluid power cylinder bores and piston rods. These O-rings are for use in general hydraulic and pneumatic applications without and with anti-extrusion rings (back-up rings). The dimensions of the O-rings (d_1 and d_2), size codes (SC) and tolerances conform to ISO 3601-1.

Housing dimensions for the O-rings intended for aerospace applications that are specified in ISO 3601-1 are addressed in informative Annex A.

NOTE 1 It is expected that O-ring housing dimensions for special applications be agreed upon between the O-ring manufacturer and the user.

NOTE 2 The terms “housing”, “groove” and “gland” are interchangeable, and their usage is a matter of local convenience. In this part of ISO 3601, the term “housing” is used exclusively.

2 Normative references

The following referenced documents are indispensable for the application of this document. For dated references, only the edition cited applies. For undated references, the latest edition of the referenced document (including any amendments) applies.

ISO 3601-1:2008, *Fluid power systems — O-rings — Part 1: Inside diameters, cross-sections, tolerances and designation codes*

ISO 3601-4, *Fluid power systems — O-rings — Part 4: Anti-extrusion rings (back-up rings)*

ISO 4287:1997, *Geometrical Product Specifications (GPS) — Surface texture: Profile method — Terms, definitions and surface texture parameters*

ISO 5598, *Fluid power systems and components — Vocabulary*

ISO 8015, *Technical drawings — Fundamental tolerancing principle*

3 Terms and definitions

For the purposes of this document, the terms and definitions given in ISO 5598 apply.

4 Symbols

The following letter symbols are used in this part of ISO 3601:

A_{cs1}	cross-sectional area of the O-ring
A_{cs2}	cross-sectional area of the O-ring housing
a	roughness of the side surface of the O-ring housing
b_x	width of the O-ring housing
b_1	width of the O-ring housing without an anti-extrusion ring (back-up ring)
b_2	width of the O-ring housing with one anti-extrusion ring (back-up ring)
b_3	width of the O-ring housing with two anti-extrusion rings (back-up rings)
b_4	width of the O-ring axial housing
C	percentage of effective O-ring cross-section compression
c	roughness of the ground surface of the O-ring housing
d	roughness of the mating surface of the O-ring
d_1	O-ring inside diameter
d_2	O-ring cross-section diameter
d_3	housing inside diameter for piston application
d_4	bore diameter for piston application
d_5	rod diameter
d_6	housing outside diameter for rod application
d_7	outside diameter of housing for axial sealing
d_8	inside diameter of housing for axial sealing
d_9	piston diameter
d_{10}	bore diameter for rod application
e	surface roughness of lead-in chamfer
F	approximate percentage of housing fill
f	housing radius (also known as edges of undefined shape)
g	extrusion gap
h	height of seal housing
R	percentage of O-ring cross-sectional reduction resulting from diametral stretch
S	percentage of inside diameter stretch
SC	O-ring size code from ISO 3601-1
t	radial housing depth
t_x	approximate radial housing depth
Y	maximum run-out tolerance
z	length of lead-in chamfer

5 O-ring housings

5.1 Typical O-ring applications

5.1.1 Figure 1 shows a typical O-ring as presented in ISO 3601-1.

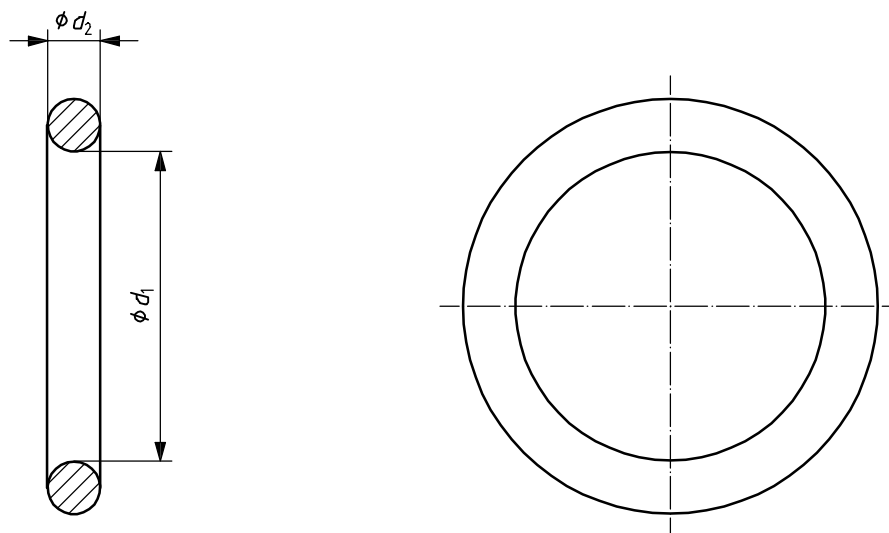

Figure 1 — Typical O-ring configuration

5.1.2 Figure 2 shows the features of an O-ring housing for use in dynamic rod and piston applications.

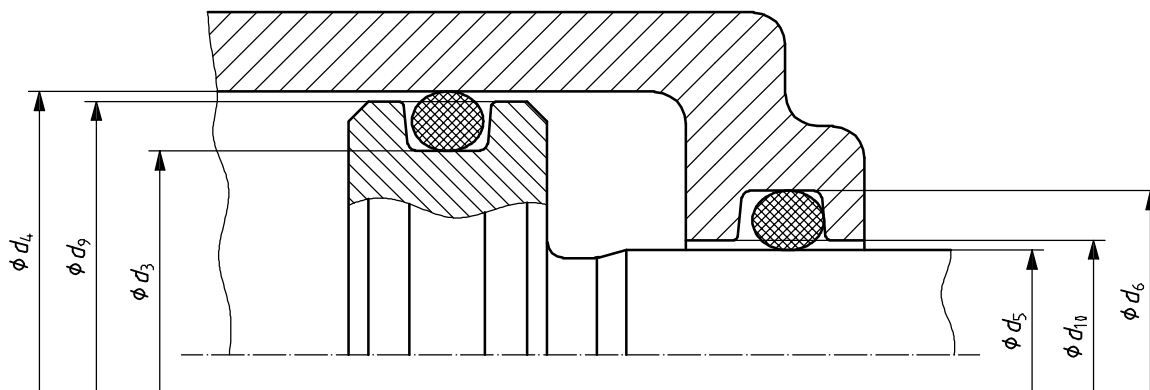

Figure 2 — Features of housings for dynamic rod and piston applications

5.1.3 Figure 3 shows the features of O-ring housings used in static rod and piston applications. It also shows an example of a face (axial) seal.

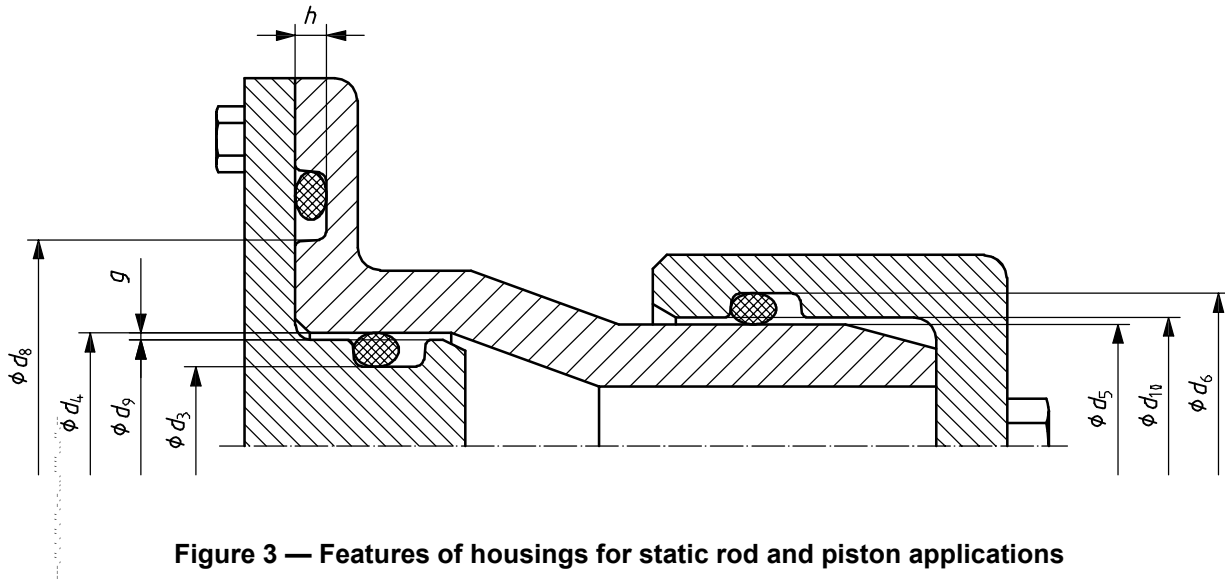
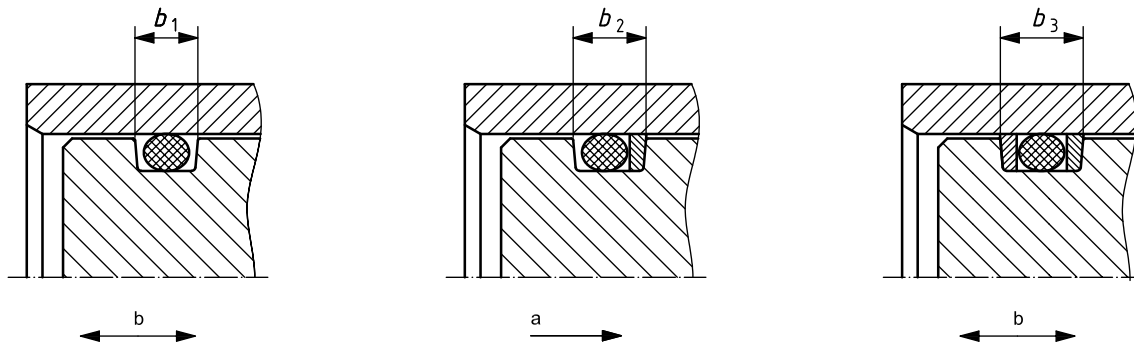

Figure 3 — Features of housings for static rod and piston applications

5.1.4 O-ring housings for face seal applications have different dimensional requirements depending upon whether the pressure is internal or external to the system. See Figure 4 for illustrations.

5.1.5 Figure 5 shows examples of widths of O-ring housings for use with or without anti-extrusion rings (back-up rings). Recommendations for the use of anti-extrusion rings are given in ISO 3601-4.



a) Without anti-extrusion rings b) With one anti-extrusion ring c) With two anti-extrusion rings

- a Pressure acting in one direction.
- b Pressure acting in alternating directions.

Figure 5 — Widths of O-ring housings, for use with or without anti-extrusion rings (back-up rings)

5.2 Surface roughness

5.2.1 The surface roughness of the O-ring housing and any mating part has a significant impact on the life and sealing performance of the O-ring.

5.2.2 Unless otherwise agreed, surface roughness values shall be in accordance with Table 1. Surface roughness values of the housings for the O-rings intended for aerospace applications that are specified in ISO 3601-1 are addressed in informative Annex A.

5.2.3 Unless otherwise agreed, the material ratio, R_{mr} , should be 50 % to 80 % for surfaces of mating parts, determined at a cut depth of $C = 0,25 R_z$, relative to a reference profile line of $C_0 = 0,05 R_{mr}$ (see ISO 4287:1997, 4.5.2).

5.3 Housing dimensions

5.3.1 Figure 6 shows a cross-section of a typical piston housing, illustrating the housing width, b_x , housing height, h , the total distance between the sealing surface and the housing height, t , the gap between the sealing elements, g , the edges of undefined shape, f , and the surfaces for which surface roughness requirements are specified. All of these features have different values depending on the application.

5.3.2 Figure 7 shows a cross-section of a typical rod housing, illustrating the housing width, b_x , housing height, h , the total distance between the sealing surface and the housing height, t , the gap between the sealing elements, g , edges of undefined shape, f , and the surfaces for which surface roughness requirements are specified. All of these features have different values depending on the application.

Dimensions in millimetres

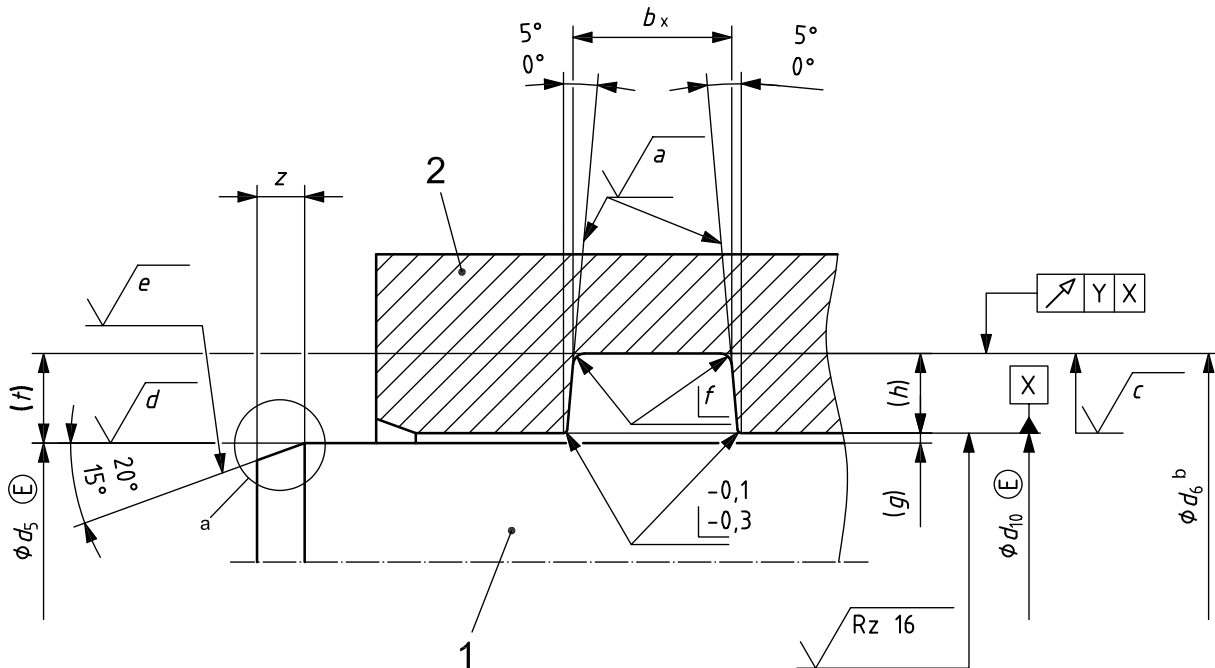

Key

- 1 rod
- 2 bore

a, c, d, e surface roughness; see Table 1

f housing radius; see Table 1

b_x width of O-ring housing

a No burrs are permitted in this area; the edge shall be rounded.

b Housing diameter $d_6 \leq 50$: maximum run-out tolerance $Y = 0,025$;
 housing diameter $d_6 > 50$: maximum run-out tolerance $Y = 0,05$.

NOTE Tolerancing is in accordance with ISO 8015.

Figure 7 — Dimensions of rod seal housings

5.3.3 The latest International Standards for surface roughness measurement require new statements for roughness requirements. Because of the short measuring length, an exact roughness is not measurable. In these cases, a visual inspection using master parts is permitted.

5.4 Corners and edges of undefined shape

Values for inside corner edge, f , that depend on the cross-sections of housings and rods are specified in Table 1. Values for the undefined edge of the housing outside corner are specified in Figures 6 and 7.

5.5 Lead-in chamfer

5.5.1 A lead-in chamfer with an angle of 15° to 20° shall be used to prevent damage to the O-ring by either the rod or the piston upon assembly into the cylinder bore. Chamfer edges shall be rounded. Figures 6 and 7 illustrate lead-in chamfers for piston and rod housings, respectively.

5.5.2 Values for the lengths of lead-in chamfers, dimension z , for the cross-sections of housings and rods are specified in Table 1.

5.6 Calculation of housing dimensions for radial sealing applications

5.6.1 General

For the basic dimensions of housings for O-rings, see Tables 2 through 5. Dimensions d_3 (for piston sealing applications) and d_6 (for rod sealing applications) and the depth of the housing apply if the percentage of effective O-ring cross-sectional compression is within the limits given in Figure 8, depending on the application and O-ring cross-section.

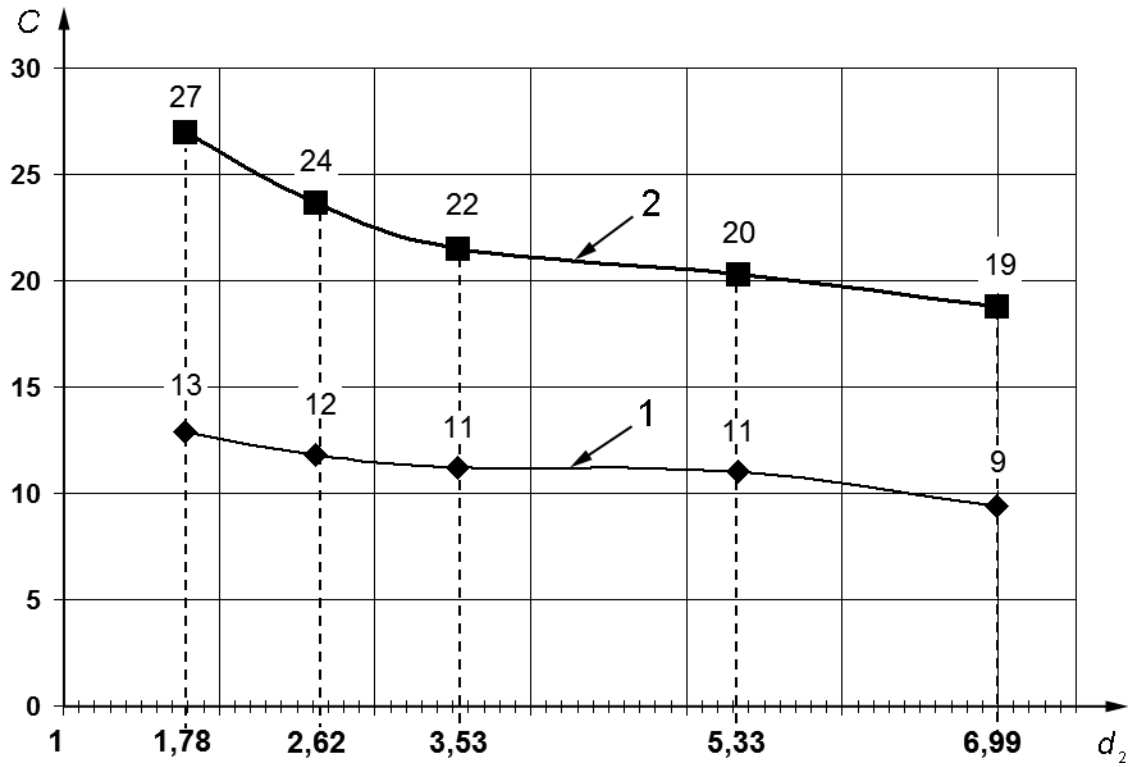

a) Hydraulic dynamic applications

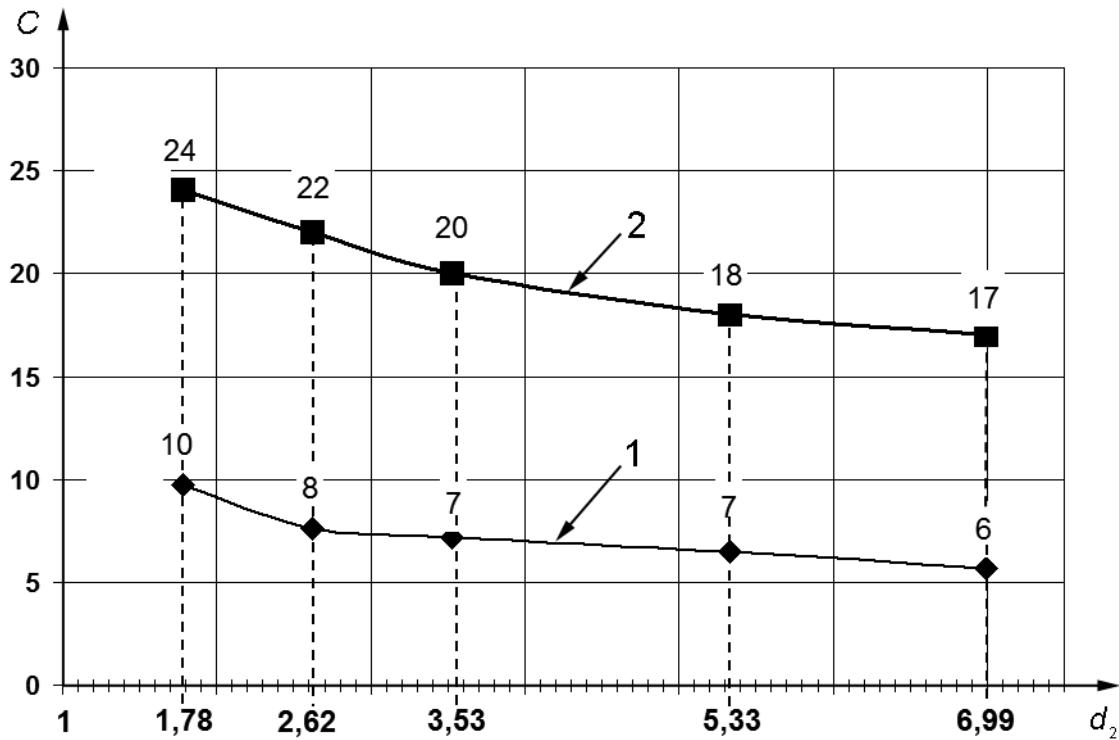

b) Pneumatic dynamic applications

Figure 8 (continued)

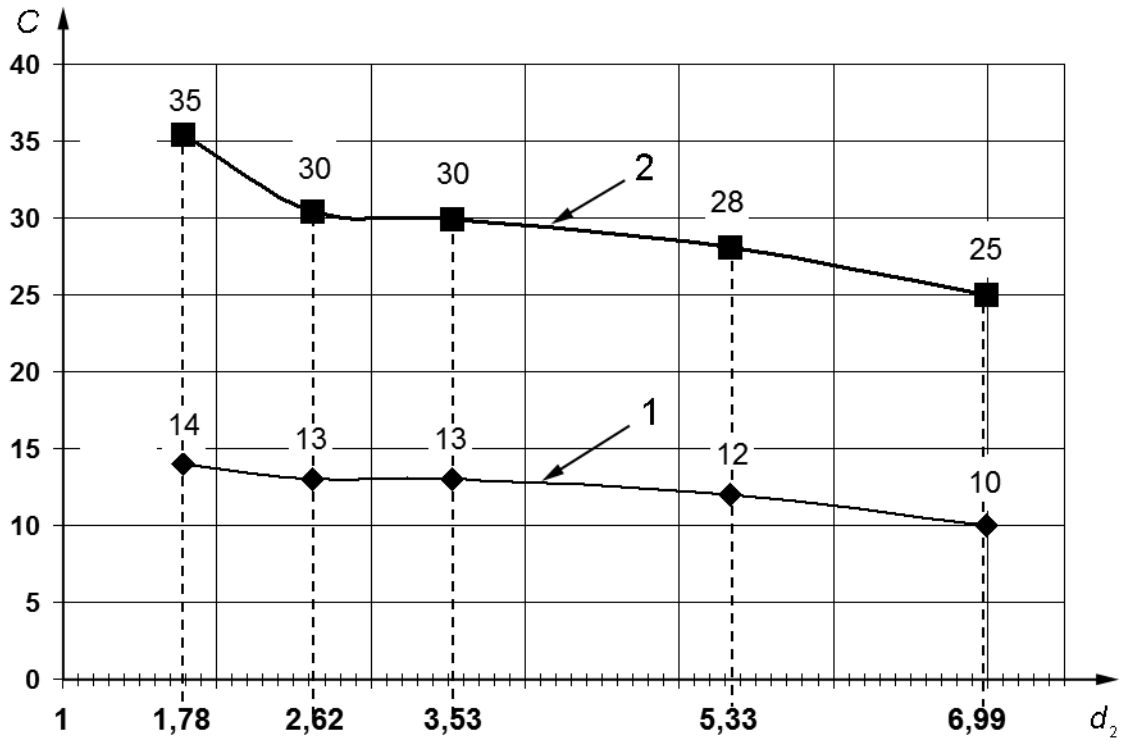

c) Hydraulic and pneumatic static applications

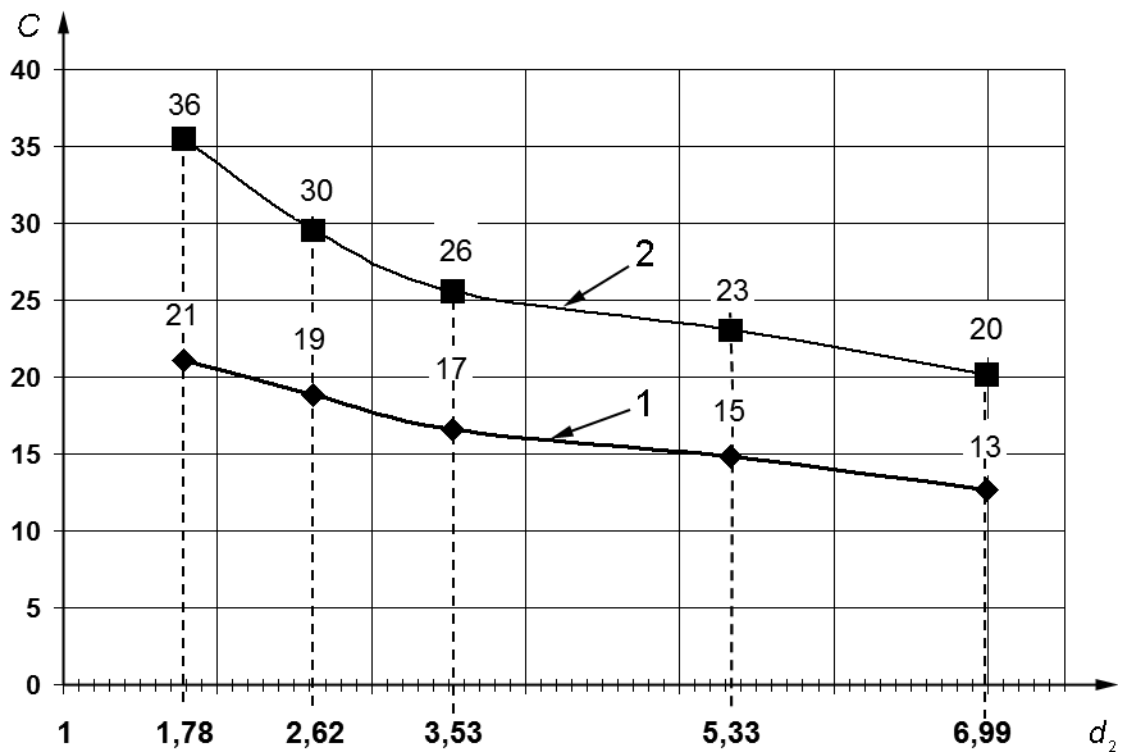

d) Hydraulic and pneumatic axial (face seal) applications

Key

- d_2 O-ring cross-section, expressed in millimetres
- C compression, expressed in percent
- 1 minimum value
- 2 maximum value

Figure 8 — Limits of compression for ISO 3601-1 O-rings

5.6.2 Percent effective compression, C

5.6.2.1 When an O-ring is stretched, its cross-section is reduced and flattened. When installed in the housing, the cross-section is no longer circular. The percentage that the cross-section is reduced depends on the percentage, S , that the inside diameter is stretched. For piston applications, S is calculated in accordance with Equations (1) and (2):

$$S_{\min} = \left[\frac{d_{3, \min} - d_{1, \max}}{d_{1, \max}} \right] \times 100 \tag{1}$$

$$S_{\max} = \left[\frac{d_{3, \max} - d_{1, \min}}{d_{1, \min}} \right] \times 100 \tag{2}$$

For rod applications, S is calculated in accordance with Equations (3) and (4):

$$S_{\min} = \left[\frac{d_{5, \min} - d_{1, \max}}{d_{1, \max}} \right] \times 100 \tag{3}$$

$$S_{\max} = \left[\frac{d_{5, \max} - d_{1, \min}}{d_{1, \min}} \right] \times 100 \tag{4}$$

5.6.2.2 The percent of cross-sectional reduction resulting from diametral stretch, R , for an O-ring whose inside diameter is stretched 0 % to 3 % (inclusive) is calculated in accordance with Equation (5):

$$R = 0,01 + 1,06(S) - 0,1(S)^2 \tag{5}$$

NOTE Equation (5) is also given in SAE MAP 3340.

EXAMPLE For an O-ring whose inside diameter is stretched 2 %, the percent effective compression is

$$\begin{aligned} R &= 0,01 + 1,06(2) - 0,1(4) \\ &= 1,73 \% \end{aligned}$$

5.6.2.3 The percent of cross-sectional reduction resulting from diametral stretch, R , for an O-ring whose inside diameter is stretched more than 3 % but less than 25 % is calculated in accordance with Equation (6):

$$R = 0,56 + 0,59(S) - 0,0046(S)^2 \tag{6}$$

5.6.2.4 The effective cross-section, d_2^* , range for the stretched O-ring is in accordance with Equations (7) and (8):

$$d_{2, \min}^* = d_{2, \min} - (R_{\max} / 100) \times d_{2, \min} \tag{7}$$

where R_{\max} is calculated according to Equation (5) or Equation (6) using S_{\max} .

Use S_{\max} .

$$d_{2, \max}^* = d_{2, \max} - (R_{\min} / 100) \times d_{2, \max} \tag{8}$$

where R_{\min} is calculated according to Equation (5) or Equation (6) using S_{\min} .

Use S_{\min} .

The range in the percent effective compression, C , is in accordance with Equations (9) and (10):

$$C_{\min} = [(d_{2,\min}^* - t_{\max}) / d_{2,\min}^*] \times 100 \quad (9)$$

$$C_{\max} = [(d_{2,\max}^* - t_{\min}) / d_{2,\max}^*] \times 100 \quad (10)$$

NOTE Percent effective compression has been considered in the development of this part of ISO 3601.

6 Requirements

6.1 Housing dimensions

6.1.1 Housings for piston sealing in hydraulic and pneumatic applications

6.1.1.1 The nominal O-ring inside diameter, d_1 , should be stretched between 2 % and 5 % for dynamic applications and 2 % and 8 % for static applications. For O-rings with a diameter d_1 smaller than 20 mm, this is not always possible, which can result in a wider range of stretch. To minimize this range and the maximum stretch, it is necessary to minimize the tolerances of the housing diameter, d_3 , and have a less stringent requirement for the minimum O-ring stretch.

In dynamic applications, it is important to keep the maximum stretch to 5 % or less to avoid detrimental effects on sealing performance.

6.1.1.2 The general housing dimensions and tolerances and housing diameter tolerances are given in Tables 2 and 3. The depth of the housing, t , can be calculated in accordance with Equation (11):

$$t = \frac{d_4 - d_3}{2} \quad (11)$$

6.1.1.3 For the key dimensions related to piston sealing, see Figure 6.

6.1.1.4 Actual housing dimensions for the standard O-rings specified in ISO 3601-1 are given in Table 2. Housing dimensions for selected metric bore sizes are given in Table 3 along with the suggested standard O-rings. For other metric bore sizes not given in Table 3, Annex B should be used for guidance to calculate hardware dimensions.

6.1.2 Housings for rod sealing in hydraulic and pneumatic applications

6.1.2.1 The O-ring outside diameter ($d_1 + 2d_2$) shall be at least equal to or larger than the housing outside diameter, d_6 , to give interference on the outside diameter. The O-ring outside diameter shall not exceed 3 % of the housing outside diameter for O-rings with a diameter d_1 greater than 250 mm, or 5 % for O-rings with a diameter d_1 smaller than 250 mm. For O-rings with a diameter d_1 smaller than 20 mm, this is not always possible due to tolerance issues, which can result in a greater outside diameter interference.

NOTE The calculation is based on the minimum O-ring outside diameter and the maximum housing diameter, d_6 .

The general housing dimensions and tolerances, and housing diameter tolerances, are given in Tables 4 and 5. The depth of the housing, t , can be calculated in accordance with Equation (12):

$$t = \frac{d_6 - d_5}{2} \quad (12)$$

6.1.2.2 For the key dimensions related to rod sealing, see Figure 7.

6.1.2.3 Actual rod housing dimensions for standard O-rings specified in ISO 3601-1 are given in Table 4. Housing dimensions are not provided for the larger diameter rod sealing applications. In these larger sizes, use of metric tolerances for the hardware and inch tolerances for the seals results in d_6 becoming larger than

the O-ring outside diameter, and this condition makes the installation of the seal impractical based upon the compression requirement stated above. For those situations where a larger-diameter rod seal is required, special tolerances should be considered. Housing dimensions for selected metric rods are given in Table 5 along with the suggested standard O-rings. For other metric rod sizes not given in Table 5, Annex B should be used for guidance to calculate hardware dimensions.

6.1.3 Housings for O-rings for use in hydraulic and pneumatic static axial sealing applications

6.1.3.1 General

In static axial sealing applications, an O-ring is compressed in axial direction. The housings addressed in 6.1.3 are depicted in Figure 4. This design minimizes the number of gaps through which the O-ring can extrude and reduces the potential damage to the O-ring during assembly. Placement of the O-ring within the housing depends on the direction from which pressure is applied. If the O-ring is pressurized from an internal source, the housing shall be designed so that, prior to the pressure being applied, the O-ring is in contact with the housing wall that is away from the side that is pressurized. The major diameter of this internal pressure housing is designated by d_7 . If the O-ring is pressurized from an external source, the housing shall be designed so that, prior to pressure being applied, the O-ring is in contact with the housing wall away from the side that is pressurized. The major diameter of this internal pressure housing is designated by d_8 . The minor diameter for the housing shall then be determined by adding or subtracting the appropriate housing width to or from the major diameter.

The housing width is determined by the type of fluid to be sealed. The housing widths are specified in Table 6, which also specifies the other detail dimensions for the housings.

6.1.3.2 Actual housing dimensions for axial sealing applications

Actual housing dimensions for the O-rings specified in ISO 3601-1 and used in axial sealing applications for internal pressure and external pressure applications are given in Table 7.

6.2 Determining O-ring size for custom housing dimensions

For hardware dimensions not listed in the previously mentioned tables, Annex B provides a procedure for identifying the proper O-ring for use in housings for specific hardware.

6.3 Housing fill consideration in design of housings

It is important to consider the housing fill or occupancy of the installed O-ring to avoid detrimental effects on radial sealing performance. Housing fill of the installed O-ring should not be more than 85 % to allow for possible O-ring thermal expansion, volume swell due to fluid exposure and effects of tolerances. Housing fill of installed O-rings was considered during the design of the housings listed in this part of ISO 3601.

6.4 Temperature consideration in design of housings

It is important to note there are significant differences in the coefficients of thermal expansion and contraction between the O-ring material and the housing materials. Elastomers can have coefficients of expansion several times higher than that of metals, such as steel. The calculations used in this part of ISO 3601, including in Annex B, have been based upon an ambient temperature of approximately 24 °C.

7 Identification statement

It is strongly recommended to manufacturers who have chosen to conform to this part of ISO 3601 that the following statement be used in test reports, catalogues and sales literature:

“Dimensions and tolerances for O-ring housings selected in accordance with ISO 3601-2, *Fluid power systems — O-rings — Part 2: Housing dimensions for general applications.*”

Table 1 — General dimensions and surface roughness requirements for piston and rod housings for use in dynamic and static hydraulic and pneumatic applications^a

Dimensions in millimetres unless otherwise noted

d_2	z^b for 15°	z for 20°	f	Surface roughness values in micrometers ^{d, e, f}					Minimum required measuring length (5 times single measuring length plus 2 times cut-offs)
				Chamfer ^c	Side surface	Housing bore or housing groove ^g	Static mating surface ^g	Dynamic mating surface ^g	
nom.	min.	min.		e	a	c	d	d	
1,78	1,1	0,9	+0,4 +0,2	Ra 1,6 visual inspection or Rz 6,3 visual inspection	Ra 1,6 visual inspection or Rz 6,3 visual inspection	Ra1 1,6 Rz1 6,3	Ra 1,6 Rz 6,3	Ra 0,4 Rz 1,6	5,6
2,62	1,5	1,1			Ra2 1,6 Rz2 6,3				
3,53	1,8	1,4	+0,8 +0,4		Ra1 1,6 Rz1 6,3	Ra3 1,6 Rz3 6,3			
5,33	2,7	2,1	Ra3 1,6 Rz3 6,3		Ra 1,6 Rz 6,3				
6,99	3,6	2,8	+1,2 +0,8		Ra4 1,6 Rz4 6,3	Ra 1,6 Rz 6,3			

- ^a See also Figures 6 and 7. See ISO 13715 for design of edges and undefined shapes.
- ^b Larger values for z (smaller angle) are better for mounting the parts together.
- ^c Shorter chamfers are recommended for dry assembly; for assembly using lubrication, longer lead-in chamfers can be utilized.
- ^d Indication of surface roughness in accordance with ISO 1302.
- ^e The descriptions of Ra1 1,6 or Rz1 6,3 do not describe a surface roughness of Ra 11,6 or Rz 16,3. According to ISO 1302, they show only a single measuring length and the roughness does not exceed 1,6 μm for Ra and 6,3 μm for Rz. A value of Ra 1,6 or Rz 6,3 can be measured only if the measuring length is longer than 5,6 mm.
- ^f Special applications can require different surface roughness values.
- ^g Visual surface imperfections are not allowed on surfaces c and d (see ISO 8785).

Table 2 — Basic dimensions of housings for O-rings used in dynamic and static pneumatic and hydraulic piston sealing applications (see Figure 6)

Dimensions in millimetres

SC	Pneumatic dynamic				Hydraulic dynamic				Static				b_1	b_2	b_3	d_1	d_2	
	d_4/d_9		d_3		d_4/d_9		d_3		d_4/d_9		d_3							+0,25 0
	nom.	tol.	nom.	tol.	nom.	tol.	nom.	tol.	nom.	tol.	nom.	tol.	nom.	nom.				
004	—	—	—	—	—	—	—	—	—	4,52	H8/f7	1,93	h6	2,8	4,2	5,6	1,78	1,78
005	—	—	—	—	—	—	—	—	—	5,31	H8/f7	2,72	h6	2,8	4,2	5,6	2,57	1,78
006	5,85	H8/f7	3,05	h6	5,74	H8/f7	3,05	h6	5,65	H8/f7	3,05	h6	2,8	4,2	5,6	2,90	1,78	
007	6,63	H8/f7	3,84	h6	6,52	H8/f7	3,83	h6	6,43	H8/f7	3,84	h6	2,8	4,2	5,6	3,68	1,78	
008	7,42	H8/f7	4,63	h6	7,31	H8/f7	4,62	h6	7,22	H8/f7	4,63	h6	2,8	4,2	5,6	4,47	1,78	
009	8,24	H8/f7	5,45	h6	8,14	H8/f7	5,45	h6	8,04	H8/f7	5,45	h6	2,8	4,2	5,6	5,28	1,78	
010	9,06	H8/f7	6,27	h6	8,93	H8/f7	6,24	h6	8,83	H8/f7	6,24	h6	2,8	4,2	5,6	6,07	1,78	
011	10,66	H8/f7	7,87	h6	10,56	H8/f7	7,87	h6	10,42	H8/f7	7,83	h6	2,8	4,2	5,6	7,65	1,78	
012	12,27	H8/f7	9,5	h8	12,22	H8/f7	9,54	h8	12,17	H8/f7	9,59	h8	2,8	4,2	5,6	9,25	1,78	
013	—	—	—	—	—	—	—	—	—	13,77	H8/f7	11,2	h8	2,8	4,2	5,6	10,82	1,78
014	—	—	—	—	—	—	—	—	—	15,4	H8/f7	12,83	h8	2,8	4,2	5,6	12,42	1,78
015	—	—	—	—	—	—	—	—	—	17,06	H8/f7	14,49	h8	2,8	4,2	5,6	14,00	1,78
016	—	—	—	—	—	—	—	—	—	18,75	H8/f7	16,17	h8	2,8	4,2	5,6	15,60	1,78
017	—	—	—	—	—	—	—	—	—	20,35	H8/f7	17,78	h8	2,8	4,2	5,6	17,17	1,78
018	—	—	—	—	—	—	—	—	—	21,98	H8/f7	19,41	h8	2,8	4,2	5,6	18,77	1,78
019	—	—	—	—	—	—	—	—	—	23,59	H8/f7	21,12	h9	2,8	4,2	5,6	20,35	1,78
020	—	—	—	—	—	—	—	—	—	25,22	H8/f7	22,75	h9	2,8	4,2	5,6	21,95	1,78
021	—	—	—	—	—	—	—	—	—	26,83	H8/f7	24,36	h9	2,8	4,2	5,6	23,52	1,78
022	—	—	—	—	—	—	—	—	—	28,48	H8/f7	26,01	h9	2,8	4,2	5,6	25,12	1,78
023	—	—	—	—	—	—	—	—	—	30,08	H8/f7	27,62	h9	2,8	4,2	5,6	26,70	1,78
024	—	—	—	—	—	—	—	—	—	31,72	H8/f7	29,25	h9	2,8	4,2	5,6	28,30	1,78
025	—	—	—	—	—	—	—	—	—	33,35	H8/f7	30,91	h9	2,8	4,2	5,6	29,87	1,78
026	—	—	—	—	—	—	—	—	—	34,99	H8/f7	32,55	h9	2,8	4,2	5,6	31,47	1,78
027	—	—	—	—	—	—	—	—	—	36,6	H8/f7	34,16	h9	2,8	4,2	5,6	33,05	1,78
028	—	—	—	—	—	—	—	—	—	38,28	H8/f7	35,84	h9	2,8	4,2	5,6	34,65	1,78
029	—	—	—	—	—	—	—	—	—	41,51	H8/f7	39,07	h9	2,8	4,2	5,6	37,62	1,78
030	—	—	—	—	—	—	—	—	—	44,76	H8/f7	42,32	h9	2,8	4,2	5,6	41,00	1,78
031	—	—	—	—	—	—	—	—	—	48,04	H8/f7	45,6	h9	2,8	4,2	5,6	44,17	1,78
032	—	—	—	—	—	—	—	—	—	51,28	H8/f7	48,84	h9	2,8	4,2	5,6	47,35	1,78
033	—	—	—	—	—	—	—	—	—	54,6	H8/f7	52,19	h9	2,8	4,2	5,6	50,52	1,78
034	—	—	—	—	—	—	—	—	—	57,84	H8/f7	55,43	h9	2,8	4,2	5,6	53,70	1,78
035	—	—	—	—	—	—	—	—	—	61,08	H8/f7	58,67	h9	2,8	4,2	5,6	56,87	1,78
036	—	—	—	—	—	—	—	—	—	64,32	H8/f7	61,91	h9	2,8	4,2	5,6	60,05	1,78
037	—	—	—	—	—	—	—	—	—	67,55	H8/f7	65,14	h9	2,8	4,2	5,6	63,22	1,78
038	—	—	—	—	—	—	—	—	—	70,85	H8/f7	68,44	h9	2,8	4,2	5,6	66,40	1,78
039	—	—	—	—	—	—	—	—	—	74,08	H8/f7	71,67	h9	2,8	4,2	5,6	69,57	1,78

Table 2 (continued)

SC	Pneumatic dynamic				Hydraulic dynamic				Static				b_1	b_2	b_3	d_1	d_2
	d_4/d_9		d_3		d_4/d_9		d_3		d_4/d_9		d_3						
	nom.	tol.	nom.	tol.	nom.	tol.	nom.	tol.	nom.	tol.	nom.	tol.	nom.	nom.			
040	—	—	—	—	—	—	—	—	77,33	H8/f7	74,92	h9	2,8	4,2	5,6	72,75	1,78
041	—	—	—	—	—	—	—	—	80,66	H8/f7	78,25	h9	2,8	4,2	5,6	75,92	1,78
042	—	—	—	—	—	—	—	—	87,14	H8/f7	84,76	h9	2,8	4,2	5,6	82,27	1,78
043	—	—	—	—	—	—	—	—	93,61	H8/f7	91,23	h9	2,8	4,2	5,6	88,62	1,78
044	—	—	—	—	—	—	—	—	100,17	H8/f7	97,79	h9	2,8	4,2	5,6	94,97	1,78
045	—	—	—	—	—	—	—	—	106,65	H8/f7	104,27	h9	2,8	4,2	5,6	101,32	1,78
046	—	—	—	—	—	—	—	—	113,2	H8/f7	110,82	h9	2,8	4,2	5,6	107,67	1,78
047	—	—	—	—	—	—	—	—	119,68	H8/f7	117,3	h9	2,8	4,2	5,6	114,02	1,78
048	—	—	—	—	—	—	—	—	126,15	H8/f7	123,8	h9	2,8	4,2	5,6	120,37	1,78
049	—	—	—	—	—	—	—	—	132,81	H8/f7	130,46	h9	2,8	4,2	5,6	126,72	1,78
050	—	—	—	—	—	—	—	—	139,29	H8/f7	136,94	h9	2,8	4,2	5,6	133,07	1,78
102	—	—	—	—	—	—	—	—	5,38	H8/f7	1,38	h6	3,8	5,2	6,6	1,24	2,62
103	—	—	—	—	—	—	—	—	6,2	H8/f7	2,21	h6	3,8	5,2	6,6	2,06	2,62
104	7,28	H8/f7	2,99	h6	7,08	H8/f7	2,99	h6	6,98	H8/f7	2,99	h6	3,8	5,2	6,6	2,84	2,62
105	8,08	H8/f7	3,79	h6	7,87	H8/f7	3,78	h6	7,78	H8/f7	3,79	h6	3,8	5,2	6,6	3,63	2,62
106	8,87	H8/f7	4,58	h6	8,66	H8/f7	4,57	h6	8,57	H8/f7	4,58	h6	3,8	5,2	6,6	4,42	2,62
107	9,69	H8/f7	5,39	h6	9,47	H8/f7	5,38	h6	9,39	H8/f7	5,39	h6	3,8	5,2	6,6	5,23	2,62
108	10,51	H8/f7	6,22	h6	10,27	H8/f7	6,17	h6	10,18	H8/f7	6,19	h6	3,8	5,2	6,6	6,02	2,62
109	12,1	H8/f7	7,82	h8	11,84	H8/f7	7,76	h8	11,8	H8/f7	7,82	h8	3,8	5,2	6,6	7,59	2,62
110	13,71	H8/f7	9,44	h8	13,56	H8/f7	9,48	h8	13,41	H8/f7	9,44	h8	3,8	5,2	6,6	9,19	2,62
111	15,31	H8/f7	11,04	h8	15,16	H8/f7	11,09	h8	15,12	H8/f7	11,14	h8	3,8	5,2	6,6	10,77	2,62
112	16,93	H8/f7	12,65	h8	16,79	H8/f7	12,71	h8	16,75	H8/f7	12,77	h8	3,8	5,2	6,6	12,37	2,62
113	18,56	H8/f7	14,29	h8	18,43	H8/f7	14,36	h8	18,4	H8/f7	14,42	h8	3,8	5,2	6,6	13,94	2,62
114	20,23	H8/f7	15,95	h8	20,11	H8/f7	16,03	h8	20,09	H8/f7	16,10	h8	3,8	5,2	6,6	15,54	2,62
115	21,82	H8/f7	17,55	h8	21,71	H8/f7	17,64	h8	21,7	H8/f7	17,72	h8	3,8	5,2	6,6	17,12	2,62
116	23,44	H8/f7	19,17	h8	23,33	H8/f7	19,27	h8	23,33	H8/f7	19,35	h8	3,8	5,2	6,6	18,72	2,62
117	—	—	—	—	—	—	—	—	24,95	H8/f7	20,97	h8	3,8	5,2	6,6	20,29	2,62
118	—	—	—	—	—	—	—	—	26,58	H8/f7	22,71	h9	3,8	5,2	6,6	21,89	2,62
119	—	—	—	—	—	—	—	—	28,19	H8/f7	24,32	h9	3,8	5,2	6,6	23,47	2,62
120	—	—	—	—	—	—	—	—	29,83	H8/f7	25,96	h9	3,8	5,2	6,6	25,07	2,62
121	—	—	—	—	—	—	—	—	31,43	H8/f7	27,56	h9	3,8	5,2	6,6	26,64	2,62
122	—	—	—	—	—	—	—	—	33,06	H8/f7	29,19	h9	3,8	5,2	6,6	28,24	2,62
123	—	—	—	—	—	—	—	—	34,72	H8/f7	30,88	h9	3,8	5,2	6,6	29,82	2,62
124	—	—	—	—	—	—	—	—	36,35	H8/f7	32,51	h9	3,8	5,2	6,6	31,42	2,62
125	—	—	—	—	—	—	—	—	37,96	H8/f7	34,12	h9	3,8	5,2	6,6	32,99	2,62
126	—	—	—	—	—	—	—	—	39,59	H8/f7	35,75	h9	3,8	5,2	6,6	34,59	2,62
127	—	—	—	—	—	—	—	—	41,20	H8/f7	37,36	h9	3,8	5,2	6,6	36,17	2,62
128	—	—	—	—	—	—	—	—	42,83	H8/f7	38,99	h9	3,8	5,2	6,6	37,77	2,62
129	—	—	—	—	—	—	—	—	44,51	H8/f7	40,67	h9	3,8	5,2	6,6	39,34	2,62

Table 2 (continued)

SC	Pneumatic dynamic				Hydraulic dynamic				Static				b ₁	b ₂	b ₃	d ₁	d ₂
	d ₄ /d ₉		d ₃		d ₄ /d ₉		d ₃		d ₄ /d ₉		d ₃						
	nom.	tol.	nom.	tol.	nom.	tol.	nom.	tol.	nom.	tol.	nom.	tol.	nom.	nom.			
130	—	—	—	—	—	—	—	—	46,15	H8/f7	42,31	h9	3,8	5,2	6,6	40,94	2,62
131	—	—	—	—	—	—	—	—	47,76	H8/f7	43,92	h9	3,8	5,2	6,6	42,52	2,62
132	—	—	—	—	—	—	—	—	49,39	H8/f7	45,55	h9	3,8	5,2	6,6	44,12	2,62
133	—	—	—	—	—	—	—	—	50,99	H8/f7	47,15	h9	3,8	5,2	6,6	45,69	2,62
134	—	—	—	—	—	—	—	—	52,62	H8/f7	48,78	h9	3,8	5,2	6,6	47,29	2,62
135	—	—	—	—	—	—	—	—	54,32	H8/f7	50,51	h9	3,8	5,2	6,6	48,90	2,62
136	—	—	—	—	—	—	—	—	55,92	H8/f7	52,11	h9	3,8	5,2	6,6	50,47	2,62
137	—	—	—	—	—	—	—	—	57,55	H8/f7	53,74	h9	3,8	5,2	6,6	52,07	2,62
138	—	—	—	—	—	—	—	—	59,15	H8/f7	55,34	h9	3,8	5,2	6,6	53,64	2,62
139	—	—	—	—	—	—	—	—	60,79	H8/f7	56,98	h9	3,8	5,2	6,6	55,25	2,62
140	—	—	—	—	—	—	—	—	62,40	H8/f7	58,59	h9	3,8	5,2	6,6	56,82	2,62
141	—	—	—	—	—	—	—	—	64,11	H8/f7	60,30	h9	3,8	5,2	6,6	58,42	2,62
142	—	—	—	—	—	—	—	—	65,71	H8/f7	61,90	h9	3,8	5,2	6,6	59,99	2,62
143	—	—	—	—	—	—	—	—	67,35	H8/f7	63,54	h9	3,8	5,2	6,6	61,60	2,62
144	—	—	—	—	—	—	—	—	68,95	H8/f7	65,14	h9	3,8	5,2	6,6	63,17	2,62
145	—	—	—	—	—	—	—	—	70,59	H8/f7	66,78	h9	3,8	5,2	6,6	64,77	2,62
146	—	—	—	—	—	—	—	—	72,19	H8/f7	68,38	h9	3,8	5,2	6,6	66,34	2,62
147	—	—	—	—	—	—	—	—	73,88	H8/f7	70,07	h9	3,8	5,2	6,6	67,95	2,62
148	—	—	—	—	—	—	—	—	75,48	H8/f7	71,67	h9	3,8	5,2	6,6	69,52	2,62
149	—	—	—	—	—	—	—	—	77,11	H8/f7	73,30	h9	3,8	5,2	6,6	71,12	2,62
150	—	—	—	—	—	—	—	—	78,72	H8/f7	74,91	h9	3,8	5,2	6,6	72,69	2,62
151	—	—	—	—	—	—	—	—	82,01	H8/f7	78,20	h9	3,8	5,2	6,6	75,87	2,62
152	—	—	—	—	—	—	—	—	88,49	H8/f7	84,71	h9	3,8	5,2	6,6	82,22	2,62
153	—	—	—	—	—	—	—	—	94,96	H8/f7	91,18	h9	3,8	5,2	6,6	88,57	2,62
154	—	—	—	—	—	—	—	—	101,54	H8/f7	97,76	h9	3,8	5,2	6,6	94,92	2,62
155	—	—	—	—	—	—	—	—	108,02	H8/f7	104,24	h9	3,8	5,2	6,6	101,27	2,62
156	—	—	—	—	—	—	—	—	114,55	H8/f7	110,77	h9	3,8	5,2	6,6	107,62	2,62
157	—	—	—	—	—	—	—	—	121,02	H8/f7	117,24	h9	3,8	5,2	6,6	113,97	2,62
158	—	—	—	—	—	—	—	—	127,50	H8/f7	123,75	h9	3,8	5,2	6,6	120,32	2,62
159	—	—	—	—	—	—	—	—	134,11	H8/f7	130,36	h9	3,8	5,2	6,6	126,67	2,62
160	—	—	—	—	—	—	—	—	140,59	H8/f7	136,84	h9	3,8	5,2	6,6	133,02	2,62
161	—	—	—	—	—	—	—	—	147,07	H8/f7	143,32	h9	3,8	5,2	6,6	139,37	2,62
162	—	—	—	—	—	—	—	—	153,54	H8/f7	149,79	h9	3,8	5,2	6,6	145,72	2,62
163	—	—	—	—	—	—	—	—	160,02	H8/f7	156,27	h9	3,8	5,2	6,6	152,07	2,62
164	—	—	—	—	—	—	—	—	166,63	H8/f7	162,88	h9	3,8	5,2	6,6	158,42	2,62
165	—	—	—	—	—	—	—	—	173,11	H8/f7	169,36	h9	3,8	5,2	6,6	164,77	2,62
166	—	—	—	—	—	—	—	—	179,58	H8/f7	175,83	h9	3,8	5,2	6,6	171,12	2,62
167	—	—	—	—	—	—	—	—	186,06	H8/f7	182,35	h9	3,8	5,2	6,6	177,47	2,62
168	—	—	—	—	—	—	—	—	192,66	H8/f7	188,95	h9	3,8	5,2	6,6	183,82	2,62
169	—	—	—	—	—	—	—	—	199,14	H8/f7	195,43	h9	3,8	5,2	6,6	190,17	2,62

Table 2 (continued)

SC	Pneumatic dynamic				Hydraulic dynamic				Static				b_1	b_2	b_3	d_1	d_2
	d_4/d_9		d_3		d_4/d_9		d_3		d_4/d_9		d_3						
	nom.	tol.	nom.	tol.	nom.	tol.	nom.	tol.	nom.	tol.	nom.	tol.	nom.	nom.			
170	—	—	—	—	—	—	—	—	205,61	H8/f7	201,9	h9	3,8	5,2	6,6	196,52	2,62
171	—	—	—	—	—	—	—	—	212,09	H8/f7	208,38	h9	3,8	5,2	6,6	202,87	2,62
172	—	—	—	—	—	—	—	—	218,70	H8/f7	214,99	h9	3,8	5,2	6,6	209,22	2,62
173	—	—	—	—	—	—	—	—	225,18	H8/f7	221,47	h9	3,8	5,2	6,6	215,57	2,62
174	—	—	—	—	—	—	—	—	231,65	H8/f7	227,94	h9	3,8	5,2	6,6	221,92	2,62
175	—	—	—	—	—	—	—	—	238,13	H8/f7	234,42	h9	3,8	5,2	6,6	228,27	2,62
176	—	—	—	—	—	—	—	—	244,74	H8/f7	241,03	h9	3,8	5,2	6,6	234,62	2,62
177	—	—	—	—	—	—	—	—	251,22	H8/f7	247,51	h9	3,8	5,2	6,6	240,97	2,62
178	—	—	—	—	—	—	—	—	257,69	H8/f7	254,01	h9	3,8	5,2	6,6	247,32	2,62
201	—	—	—	—	—	—	—	—	9,91	H8/f7	4,53	h9	5,0	6,4	7,8	4,34	3,53
202	—	—	—	—	—	—	—	—	11,53	H8/f7	6,17	h9	5,0	6,4	7,8	5,94	3,53
203	—	—	—	—	—	—	—	—	13,13	H8/f7	7,76	h9	5,0	6,4	7,8	7,52	3,53
204	—	—	—	—	—	—	—	—	14,74	H8/f7	9,38	h9	5,0	6,4	7,8	9,12	3,53
205	—	—	—	—	—	—	—	—	16,44	H8/f7	11,08	h9	5,0	6,4	7,8	10,69	3,53
206	—	—	—	—	—	—	—	—	18,07	H8/f7	12,71	h9	5,0	6,4	7,8	12,29	3,53
207	—	—	—	—	—	—	—	—	19,73	H8/f7	14,37	h9	5,0	6,4	7,8	13,87	3,53
208	—	—	—	—	—	—	—	—	21,41	H8/f7	16,06	h9	5,0	6,4	7,8	15,47	3,53
209	—	—	—	—	—	—	—	—	23,02	H8/f7	17,66	h9	5,0	6,4	7,8	17,04	3,53
210	25,17	H8/f7	19,32	h9	24,97	H8/f7	19,32	h9	24,67	H8/f7	19,32	h9	5,0	6,4	7,8	18,64	3,53
211	26,78	H8/f7	20,93	h9	26,56	H8/f7	20,93	h9	26,28	H8/f7	20,93	h9	5,0	6,4	7,8	20,22	3,53
212	28,41	H8/f7	22,64	h9	28,21	H8/f7	22,64	h9	27,91	H8/f7	22,64	h9	5,0	6,4	7,8	21,82	3,53
213	30,01	H8/f7	24,24	h9	29,81	H8/f7	24,24	h9	29,51	H8/f7	24,24	h9	5,0	6,4	7,8	23,39	3,53
214	31,64	H8/f7	25,87	h9	31,44	H8/f7	25,87	h9	31,14	H8/f7	25,87	h9	5,0	6,4	7,8	24,99	3,53
215	33,26	H8/f7	27,49	h9	33,06	H8/f7	27,49	h9	32,76	H8/f7	27,49	h9	5,0	6,4	7,8	26,57	3,53
216	34,94	H8/f7	29,17	h9	34,74	H8/f7	29,17	h9	34,44	H8/f7	29,17	h9	5,0	6,4	7,8	28,17	3,53
217	36,54	H8/f7	30,8	h9	36,34	H8/f7	30,8	h9	36,04	H8/f7	30,8	h9	5,0	6,4	7,8	29,74	3,53
218	38,17	H8/f7	32,43	h9	37,97	H8/f7	32,43	h9	37,67	H8/f7	32,43	h9	5,0	6,4	7,8	31,34	3,53
219	39,78	H8/f7	34,04	h9	39,58	H8/f7	34,04	h9	39,28	H8/f7	34,04	h9	5,0	6,4	7,8	32,92	3,53
220	41,42	H8/f7	35,68	h9	41,22	H8/f7	35,68	h9	40,92	H8/f7	35,68	h9	5,0	6,4	7,8	34,52	3,53
221	43,02	H8/f7	37,28	h9	42,82	H8/f7	37,28	h9	42,52	H8/f7	37,28	h9	5,0	6,4	7,8	36,09	3,53
222	44,73	H8/f7	38,99	h9	44,53	H8/f7	38,99	h9	44,23	H8/f7	38,99	h9	5,0	6,4	7,8	37,69	3,53
223	—	—	—	—	—	—	—	—	47,48	H8/f7	42,24	h9	5,0	6,4	7,8	40,87	3,53
224	—	—	—	—	—	—	—	—	50,71	H8/f7	45,47	h9	5,0	6,4	7,8	44,04	3,53
225	—	—	—	—	—	—	—	—	54,03	H8/f7	48,79	h9	5,0	6,4	7,8	47,22	3,53
226	—	—	—	—	—	—	—	—	57,27	H8/f7	52,06	h9	5,0	6,4	7,8	50,39	3,53
227	—	—	—	—	—	—	—	—	60,51	H8/f7	55,3	h9	5,0	6,4	7,8	53,57	3,53
228	—	—	—	—	—	—	—	—	63,80	H8/f7	58,59	h9	5,0	6,4	7,8	56,74	3,53
229	—	—	—	—	—	—	—	—	67,04	H8/f7	61,83	h9	5,0	6,4	7,8	59,92	3,53

Table 2 (continued)

SC	Pneumatic dynamic				Hydraulic dynamic				Static				b ₁	b ₂	b ₃	d ₁	d ₂
	d ₄ /d ₉		d ₃		d ₄ /d ₉		d ₃		d ₄ /d ₉		d ₃						
	nom.	tol.	nom.	tol.	nom.	tol.	nom.	tol.	nom.	tol.	nom.	tol.	nom.	nom.			
230	—	—	—	—	—	—	—	—	70,27	H8/f7	65,06	h9	5,0	6,4	7,8	63,09	3,53
231	—	—	—	—	—	—	—	—	73,52	H8/f7	68,31	h9	5,0	6,4	7,8	66,27	3,53
232	—	—	—	—	—	—	—	—	76,85	H8/f7	71,64	h9	5,0	6,4	7,8	69,44	3,53
233	—	—	—	—	—	—	—	—	80,09	H8/f7	74,88	h9	5,0	6,4	7,8	72,62	3,53
234	—	—	—	—	—	—	—	—	83,33	H8/f7	78,12	h9	5,0	6,4	7,8	75,79	3,53
235	—	—	—	—	—	—	—	—	86,57	H8/f7	81,39	h9	5,0	6,4	7,8	78,97	3,53
236	—	—	—	—	—	—	—	—	89,81	H8/f7	84,63	h9	5,0	6,4	7,8	82,14	3,53
237	—	—	—	—	—	—	—	—	93,05	H8/f7	87,87	h9	5,0	6,4	7,8	85,32	3,53
238	—	—	—	—	—	—	—	—	96,28	H8/f7	91,10	h9	5,0	6,4	7,8	88,49	3,53
239	—	—	—	—	—	—	—	—	99,63	H8/f7	94,45	h9	5,0	6,4	7,8	91,67	3,53
240	—	—	—	—	—	—	—	—	102,86	H8/f7	97,68	h9	5,0	6,4	7,8	94,84	3,53
241	—	—	—	—	—	—	—	—	106,1	H8/f7	100,92	h9	5,0	6,4	7,8	98,02	3,53
242	—	—	—	—	—	—	—	—	109,34	H8/f7	104,16	h9	5,0	6,4	7,8	101,19	3,53
243	—	—	—	—	—	—	—	—	112,58	H8/f7	107,40	h9	5,0	6,4	7,8	104,37	3,53
244	—	—	—	—	—	—	—	—	115,87	H8/f7	110,69	h9	5,0	6,4	7,8	107,54	3,53
245	—	—	—	—	—	—	—	—	119,11	H8/f7	113,93	h9	5,0	6,4	7,8	110,72	3,53
246	—	—	—	—	—	—	—	—	122,34	H8/f7	117,16	h9	5,0	6,4	7,8	113,89	3,53
247	—	—	—	—	—	—	—	—	125,59	H8/f7	120,44	h9	5,0	6,4	7,8	117,07	3,53
248	—	—	—	—	—	—	—	—	128,82	H8/f7	123,67	h9	5,0	6,4	7,8	120,24	3,53
249	—	—	—	—	—	—	—	—	132,2	H8/f7	127,05	h9	5,0	6,4	7,8	123,42	3,53
250	—	—	—	—	—	—	—	—	135,43	H8/f7	130,28	h9	5,0	6,4	7,8	126,59	3,53
251	—	—	—	—	—	—	—	—	138,67	H8/f7	133,52	h9	5,0	6,4	7,8	129,77	3,53
252	—	—	—	—	—	—	—	—	141,91	H8/f7	136,76	h9	5,0	6,4	7,8	132,94	3,53
253	—	—	—	—	—	—	—	—	145,15	H8/f7	140,00	h9	5,0	6,4	7,8	136,12	3,53
254	—	—	—	—	—	—	—	—	148,38	H8/f7	143,23	h9	5,0	6,4	7,8	139,29	3,53
255	—	—	—	—	—	—	—	—	151,63	H8/f7	146,48	h9	5,0	6,4	7,8	142,47	3,53
256	—	—	—	—	—	—	—	—	154,86	H8/f7	149,71	h9	5,0	6,4	7,8	145,64	3,53
257	—	—	—	—	—	—	—	—	158,10	H8/f7	152,95	h9	5,0	6,4	7,8	148,82	3,53
258	—	—	—	—	—	—	—	—	161,34	H8/f7	156,19	h9	5,0	6,4	7,8	151,99	3,53
259	—	—	—	—	—	—	—	—	167,95	H8/f7	162,80	h9	5,0	6,4	7,8	158,34	3,53
260	—	—	—	—	—	—	—	—	174,42	H8/f7	169,27	h9	5,0	6,4	7,8	164,69	3,53
261	—	—	—	—	—	—	—	—	180,90	H8/f7	175,75	h9	5,0	6,4	7,8	171,04	3,53
262	—	—	—	—	—	—	—	—	187,38	H8/f7	182,27	h9	5,0	6,4	7,8	177,39	3,53
263	—	—	—	—	—	—	—	—	193,98	H8/f7	188,87	h9	5,0	6,4	7,8	183,74	3,53
264	—	—	—	—	—	—	—	—	200,45	H8/f7	195,34	h9	5,0	6,4	7,8	190,09	3,53
265	—	—	—	—	—	—	—	—	206,93	H8/f7	201,82	h9	5,0	6,4	7,8	196,44	3,53
266	—	—	—	—	—	—	—	—	213,41	H8/f7	208,30	h9	5,0	6,4	7,8	202,79	3,53
267	—	—	—	—	—	—	—	—	220,02	H8/f7	214,91	h9	5,0	6,4	7,8	209,14	3,53
268	—	—	—	—	—	—	—	—	226,50	H8/f7	221,39	h9	5,0	6,4	7,8	215,49	3,53
269	—	—	—	—	—	—	—	—	232,97	H8/f7	227,86	h9	5,0	6,4	7,8	221,84	3,53

Table 2 (continued)

SC	Pneumatic dynamic				Hydraulic dynamic				Static				b_1	b_2	b_3	d_1	d_2
	d_4/d_9		d_3		d_4/d_9		d_3		d_4/d_9		d_3						
	nom.	tol.	nom.	tol.	nom.	tol.	nom.	tol.	nom.	tol.	nom.	tol.	nom.	nom.			
270	—	—	—	—	—	—	—	—	239,45	H8/f7	234,34	h9	5,0	6,4	7,8	228,19	3,53
271	—	—	—	—	—	—	—	—	246,06	H8/f7	240,95	h9	5,0	6,4	7,8	234,54	3,53
272	—	—	—	—	—	—	—	—	252,54	H8/f7	247,43	h9	5,0	6,4	7,8	240,89	3,53
273	—	—	—	—	—	—	—	—	259,01	H8/f7	253,93	h9	5,0	6,4	7,8	247,24	3,53
274	—	—	—	—	—	—	—	—	265,49	H8/f7	260,41	h9	5,0	6,4	7,8	253,59	3,53
275	—	—	—	—	—	—	—	—	278,44	H8/f7	273,36	h9	5,0	6,4	7,8	266,29	3,53
276	—	—	—	—	—	—	—	—	291,65	H8/f7	286,57	h9	5,0	6,4	7,8	278,99	3,53
277	—	—	—	—	—	—	—	—	304,61	H8/f7	299,53	h9	5,0	6,4	7,8	291,69	3,53
278	—	—	—	—	—	—	—	—	317,56	H8/f7	312,48	h9	5,0	6,4	7,8	304,39	3,53
279	—	—	—	—	—	—	—	—	343,47	H8/f7	338,43	h9	5,0	6,4	7,8	329,79	3,53
280	—	—	—	—	—	—	—	—	369,38	H8/f7	364,34	h9	5,0	6,4	7,8	355,19	3,53
281	—	—	—	—	—	—	—	—	395,28	H8/f7	390,24	h9	5,0	6,4	7,8	380,59	3,53
282	—	—	—	—	—	—	—	—	417,65	H8/f7	412,65	h9	5,0	6,4	7,8	405,26	3,53
283	—	—	—	—	—	—	—	—	446,74	H8/f7	441,74	h9	5,0	6,4	7,8	430,68	3,53
284	—	—	—	—	—	—	—	—	472,78	H8/f7	467,78	h9	5,0	6,4	7,8	456,06	3,53
309	19,50	H8/f7	10,84	h9	19,50	H8/f7	10,84	h9	19,00	H8/f7	10,83	h9	7,2	9,0	10,9	10,46	5,33
310	21,14	H8/f7	12,49	h9	21,14	H8/f7	12,49	h9	20,64	H8/f7	12,47	h9	7,2	9,0	10,9	12,07	5,33
311	22,80	H8/f7	14,14	h9	22,80	H8/f7	14,14	h9	22,30	H8/f7	14,13	h9	7,2	9,0	10,9	13,64	5,33
312	24,48	H8/f7	15,82	h9	24,48	H8/f7	15,82	h9	23,98	H8/f7	15,81	h9	7,2	9,0	10,9	15,24	5,33
313	26,08	H8/f7	17,42	h9	26,08	H8/f7	17,42	h9	25,58	H8/f7	17,41	h9	7,2	9,0	10,9	16,81	5,33
314	27,74	H8/f7	19,10	h9	27,74	H8/f7	19,10	h9	27,24	H8/f7	19,08	h9	7,2	9,0	10,9	18,42	5,33
315	29,34	H8/f7	20,70	h9	29,34	H8/f7	20,70	h9	28,84	H8/f7	20,68	h9	7,2	9,0	10,9	19,99	5,33
316	30,98	H8/f7	22,41	h9	30,98	H8/f7	22,41	h9	30,48	H8/f7	22,37	h9	7,2	9,0	10,9	21,59	5,33
317	32,58	H8/f7	24,01	h9	32,58	H8/f7	24,01	h9	32,08	H8/f7	24,01	h9	7,2	9,0	10,9	23,16	5,33
318	34,22	H8/f7	25,65	h9	34,22	H8/f7	25,65	h9	33,72	H8/f7	25,65	h9	7,2	9,0	10,9	24,77	5,33
319	35,82	H8/f7	27,25	h9	35,82	H8/f7	27,25	h9	35,32	H8/f7	27,25	h9	7,2	9,0	10,9	26,34	5,33
320	37,50	H8/f7	28,93	h9	37,50	H8/f7	28,93	h9	37,00	H8/f7	28,93	h9	7,2	9,0	10,9	27,94	5,33
321	39,11	H8/f7	30,57	h9	39,11	H8/f7	30,57	h9	38,61	H8/f7	30,57	h9	7,2	9,0	10,9	29,51	5,33
322	40,75	H8/f7	32,21	h9	40,75	H8/f7	32,21	h9	40,25	H8/f7	32,21	h9	7,2	9,0	10,9	31,12	5,33
323	42,35	H8/f7	33,81	h9	42,35	H8/f7	33,81	h9	41,85	H8/f7	33,81	h9	7,2	9,0	10,9	32,69	5,33
324	43,98	H8/f7	35,44	h9	43,98	H8/f7	35,44	h9	43,48	H8/f7	35,44	h9	7,2	9,0	10,9	34,29	5,33
325	47,31	H8/f7	38,77	h9	47,31	H8/f7	38,77	h9	46,81	H8/f7	38,77	h9	7,2	9,0	10,9	37,47	5,33
326	50,54	H8/f7	42,00	h9	50,54	H8/f7	42,00	h9	50,04	H8/f7	42,00	h9	7,2	9,0	10,9	40,64	5,33
327	53,78	H8/f7	45,24	h9	53,78	H8/f7	45,24	h9	53,28	H8/f7	45,24	h9	7,2	9,0	10,9	43,82	5,33
328	57,02	H8/f7	48,48	h9	57,02	H8/f7	48,48	h9	56,52	H8/f7	48,48	h9	7,2	9,0	10,9	46,99	5,33
329	60,34	H8/f7	51,83	h9	60,34	H8/f7	51,83	h9	59,84	H8/f7	51,83	h9	7,2	9,0	10,9	50,17	5,33
330	63,58	H8/f7	55,07	h9	63,58	H8/f7	55,07	h9	63,08	H8/f7	55,07	h9	7,2	9,0	10,9	53,34	5,33
331	66,82	H8/f7	58,31	h9	66,82	H8/f7	58,31	h9	66,32	H8/f7	58,31	h9	7,2	9,0	10,9	56,52	5,33
332	70,05	H8/f7	61,54	h9	70,05	H8/f7	61,54	h9	69,55	H8/f7	61,54	h9	7,2	9,0	10,9	59,69	5,33
333	73,35	H8/f7	64,84	h9	73,35	H8/f7	64,84	h9	72,85	H8/f7	64,84	h9	7,2	9,0	10,9	62,87	5,33

Table 2 (continued)

SC	Pneumatic dynamic				Hydraulic dynamic				Static				b_1	b_2	b_3	d_1	d_2
	d_4/d_9		d_3		d_4/d_9		d_3		d_4/d_9		d_3		$\begin{matrix} +0,25 \\ 0 \end{matrix}$			nom.	nom.
	nom.	tol.	nom.	tol.	nom.	tol.	nom.	tol.	nom.	tol.	nom.	tol.					
334	76,58	H8/f7	68,07	h9	76,58	H8/f7	68,07	h9	76,08	H8/f7	68,07	h9	7,2	9,0	10,9	66,04	5,33
335	79,82	H8/f7	71,31	h9	79,82	H8/f7	71,31	h9	79,32	H8/f7	71,31	h9	7,2	9,0	10,9	69,22	5,33
336	83,06	H8/f7	74,55	h9	83,06	H8/f7	74,55	h9	82,56	H8/f7	74,55	h9	7,2	9,0	10,9	72,39	5,33
337	86,40	H8/f7	77,89	h9	86,40	H8/f7	77,89	h9	85,80	H8/f7	77,89	h9	7,2	9,0	10,9	75,57	5,33
338	89,64	H8/f7	81,16	h9	89,64	H8/f7	81,16	h9	89,14	H8/f7	81,16	h9	7,2	9,0	10,9	78,74	5,33
339	92,88	H8/f7	84,40	h9	92,88	H8/f7	84,40	h9	92,38	H8/f7	84,40	h9	7,2	9,0	10,9	81,92	5,33
340	96,11	H8/f7	87,63	h9	96,11	H8/f7	87,63	h9	95,61	H8/f7	87,63	h9	7,2	9,0	10,9	85,09	5,33
341	99,36	H8/f7	90,88	h9	99,36	H8/f7	90,88	h9	98,86	H8/f7	90,88	h9	7,2	9,0	10,9	88,27	5,33
342	102,69	H8/f7	94,21	h9	102,69	H8/f7	94,21	h9	102,19	H8/f7	94,21	h9	7,2	9,0	10,9	91,44	5,33
343	105,94	H8/f7	97,46	h9	105,94	H8/f7	97,46	h9	105,44	H8/f7	97,46	h9	7,2	9,0	10,9	94,62	5,33
344	109,17	H8/f7	100,69	h9	109,17	H8/f7	100,69	h9	108,67	H8/f7	100,69	h9	7,2	9,0	10,9	97,79	5,33
345	112,41	H8/f7	103,93	h9	112,41	H8/f7	103,93	h9	111,91	H8/f7	103,93	h9	7,2	9,0	10,9	100,97	5,33
346	115,65	H8/f7	107,17	h9	115,65	H8/f7	107,17	h9	115,15	H8/f7	107,17	h9	7,2	9,0	10,9	104,14	5,33
347	118,94	H8/f7	110,46	h9	118,94	H8/f7	110,46	h9	118,44	H8/f7	110,46	h9	7,2	9,0	10,9	107,32	5,33
348	122,18	H8/f7	113,70	h9	122,18	H8/f7	113,70	h9	121,68	H8/f7	113,70	h9	7,2	9,0	10,9	110,49	5,33
349	125,42	H8/f7	116,94	h9	125,42	H8/f7	116,94	h9	124,92	H8/f7	116,94	h9	7,2	9,0	10,9	113,67	5,33
350	—	—	—	—	—	—	—	—	128,15	H8/f7	120,17	h9	7,2	9,0	10,9	116,84	5,33
351	—	—	—	—	—	—	—	—	131,40	H8/f7	123,45	h9	7,2	9,0	10,9	120,02	5,33
352	—	—	—	—	—	—	—	—	134,63	H8/f7	126,88	h9	7,2	9,0	10,9	123,19	5,33
353	—	—	—	—	—	—	—	—	138,06	H8/f7	130,11	h9	7,2	9,0	10,9	126,37	5,33
354	—	—	—	—	—	—	—	—	141,29	H8/f7	133,34	h9	7,2	9,0	10,9	129,54	5,33
355	—	—	—	—	—	—	—	—	144,53	H8/f7	136,58	h9	7,2	9,0	10,9	132,72	5,33
356	—	—	—	—	—	—	—	—	147,77	H8/f7	139,82	h9	7,2	9,0	10,9	135,89	5,33
357	—	—	—	—	—	—	—	—	151,01	H8/f7	143,06	h9	7,2	9,0	10,9	139,07	5,33
358	—	—	—	—	—	—	—	—	154,24	H8/f7	146,29	h9	7,2	9,0	10,9	142,24	5,33
359	—	—	—	—	—	—	—	—	157,49	H8/f7	149,54	h9	7,2	9,0	10,9	145,42	5,33
360	—	—	—	—	—	—	—	—	160,72	H8/f7	152,77	h9	7,2	9,0	10,9	148,59	5,33
361	—	—	—	—	—	—	—	—	163,96	H8/f7	156,01	h9	7,2	9,0	10,9	151,77	5,33
362	—	—	—	—	—	—	—	—	170,52	H8/f7	162,57	h9	7,2	9,0	10,9	158,12	5,33
363	—	—	—	—	—	—	—	—	177,00	H8/f7	169,05	h9	7,2	9,0	10,9	164,47	5,33
364	—	—	—	—	—	—	—	—	183,48	H8/f7	175,53	h9	7,2	9,0	10,9	170,82	5,33
365	—	—	—	—	—	—	—	—	189,95	H8/f7	182,04	h9	7,2	9,0	10,9	177,17	5,33
366	—	—	—	—	—	—	—	—	196,55	H8/f7	188,64	h9	7,2	9,0	10,9	183,52	5,33
367	—	—	—	—	—	—	—	—	203,03	H8/f7	195,12	h9	7,2	9,0	10,9	189,87	5,33
368	—	—	—	—	—	—	—	—	209,51	H8/f7	201,60	h9	7,2	9,0	10,9	196,22	5,33
369	—	—	—	—	—	—	—	—	215,98	H8/f7	208,07	h9	7,2	9,0	10,9	202,57	5,33
370	—	—	—	—	—	—	—	—	222,59	H8/f7	214,68	h9	7,2	9,0	10,9	208,92	5,33
371	—	—	—	—	—	—	—	—	229,07	H8/f7	221,16	h9	7,2	9,0	10,9	215,27	5,33
372	—	—	—	—	—	—	—	—	235,55	H8/f7	227,64	h9	7,2	9,0	10,9	221,62	5,33
373	—	—	—	—	—	—	—	—	242,02	H8/f7	234,11	h9	7,2	9,0	10,9	227,97	5,33

Table 2 (continued)

SC	Pneumatic dynamic				Hydraulic dynamic				Static				b ₁	b ₂	b ₃	d ₁	d ₂
	d ₄ /d ₉		d ₃		d ₄ /d ₉		d ₃		d ₄ /d ₉		d ₃						
	nom.	tol.	nom.	tol.	nom.	tol.	nom.	tol.	nom.	tol.	nom.	tol.	nom.	nom.			
374	—	—	—	—	—	—	—	—	248,63	H8/f7	240,72	h9	7,2	9,0	10,9	234,32	5,33
375	—	—	—	—	—	—	—	—	255,11	H8/f7	247,20	h9	7,2	9,0	10,9	240,67	5,33
376	—	—	—	—	—	—	—	—	261,59	H8/f7	253,71	h9	7,2	9,0	10,9	247,02	5,33
377	—	—	—	—	—	—	—	—	268,07	H8/f7	260,19	h9	7,2	9,0	10,9	253,37	5,33
378	—	—	—	—	—	—	—	—	281,14	H8/f7	273,26	h9	7,2	9,0	10,9	266,07	5,33
379	—	—	—	—	—	—	—	—	294,10	H8/f7	286,22	h9	7,2	9,0	10,9	278,77	5,33
380	—	—	—	—	—	—	—	—	307,18	H8/f7	299,3	h9	7,2	9,0	10,9	291,47	5,33
381	—	—	—	—	—	—	—	—	320,14	H8/f7	312,26	h9	7,2	9,0	10,9	304,17	5,33
382	—	—	—	—	—	—	—	—	346,04	H8/f7	338,20	h9	7,2	9,0	10,9	329,57	5,33
383	—	—	—	—	—	—	—	—	372,09	H8/f7	364,25	h9	7,2	9,0	10,9	354,97	5,33
384	—	—	—	—	—	—	—	—	397,99	H8/f7	390,15	h9	7,2	9,0	10,9	380,37	5,33
384	—	—	—	—	—	—	—	—	423,51	H8/f7	415,71	h9	7,2	9,0	10,9	405,26	5,33
386	—	—	—	—	—	—	—	—	449,54	H8/f7	441,74	h9	7,2	9,0	10,9	430,66	5,33
387	—	—	—	—	—	—	—	—	475,58	H8/f7	467,78	h9	7,2	9,0	10,9	456,06	5,33
388	—	—	—	—	—	—	—	—	501,54	H8/f7	493,74	h9	7,2	9,0	10,9	481,38	5,33
389	—	—	—	—	—	—	—	—	527,57	H8/f7	519,81	h9	7,2	9,0	10,9	506,78	5,33
390	—	—	—	—	—	—	—	—	553,48	H8/f7	545,72	h9	7,2	9,0	10,9	532,18	5,33
391	—	—	—	—	—	—	—	—	579,52	H8/f7	571,76	h9	7,2	9,0	10,9	557,58	5,33
392	—	—	—	—	—	—	—	—	605,26	H8/f7	597,50	h9	7,2	9,0	10,9	582,68	5,33
393	—	—	—	—	—	—	—	—	631,29	H8/f7	623,53	h9	7,2	9,0	10,9	608,08	5,33
394	—	—	—	—	—	—	—	—	657,33	H8/f7	649,61	h9	7,2	9,0	10,9	633,48	5,33
395	—	—	—	—	—	—	—	—	683,37	H8/f7	675,65	h9	7,2	9,0	10,9	658,88	5,33
425	128,50	H8/f7	117,02	h9	128,50	H8/f7	117,02	h9	127,80	H8/f7	117,02	h9	9,5	12,3	15,1	113,67	6,99
426	131,73	H8/f7	120,28	h9	131,73	H8/f7	120,28	h9	131,03	H8/f7	120,28	h9	9,5	12,3	15,1	116,84	6,99
427	134,98	H8/f7	123,53	h9	134,98	H8/f7	123,53	h9	134,28	H8/f7	123,53	h9	9,5	12,3	15,1	120,02	6,99
428	138,21	H8/f7	126,76	h9	138,21	H8/f7	126,76	h9	137,51	H8/f7	126,76	h9	9,5	12,3	15,1	123,19	6,99
429	141,56	H8/f7	130,11	h9	141,56	H8/f7	130,11	h9	140,86	H8/f7	130,11	h9	9,5	12,3	15,1	126,37	6,99
430	144,79	H8/f7	133,34	h9	144,79	H8/f7	133,34	h9	144,09	H8/f7	133,34	h9	9,5	12,3	15,1	129,54	6,99
431	148,03	H8/f7	136,58	h9	148,03	H8/f7	136,58	h9	147,33	H8/f7	136,58	h9	9,5	12,3	15,1	132,72	6,99
432	151,27	H8/f7	139,82	h9	151,27	H8/f7	139,82	h9	150,57	H8/f7	139,82	h9	9,5	12,3	15,1	135,89	6,99
433	154,51	H8/f7	143,06	h9	154,51	H8/f7	143,06	h9	153,81	H8/f7	143,06	h9	9,5	12,3	15,1	139,07	6,99
434	157,74	H8/f7	146,29	h9	157,74	H8/f7	146,29	h9	157,04	H8/f7	146,29	h9	9,5	12,3	15,1	142,24	6,99
435	160,99	H8/f7	149,54	h9	160,99	H8/f7	149,54	h9	160,29	H8/f7	149,54	h9	9,5	12,3	15,1	145,42	6,99
436	164,22	H8/f7	152,77	h9	164,22	H8/f7	152,77	h9	163,52	H8/f7	152,77	h9	9,5	12,3	15,1	148,59	6,99
437	167,46	H8/f7	156,01	h9	167,46	H8/f7	156,01	h9	166,76	H8/f7	156,01	h9	9,5	12,3	15,1	151,77	6,99
438	174,02	H8/f7	162,57	h9	174,02	H8/f7	162,57	h9	173,32	H8/f7	162,57	h9	9,5	12,3	15,1	158,12	6,99
439	180,50	H8/f7	169,05	h9	180,50	H8/f7	169,05	h9	179,80	H8/f7	169,05	h9	9,5	12,3	15,1	164,47	6,99

Table 2 (continued)

SC	Pneumatic dynamic				Hydraulic dynamic				Static				b ₁	b ₂	b ₃	d ₁	d ₂
	d ₄ /d ₉		d ₃		d ₄ /d ₉		d ₃		d ₄ /d ₉		d ₃						
	nom.	tol.	nom.	tol.	nom.	tol.	nom.	tol.	nom.	tol.	nom.	tol.					
440	186,98	H8/f7	175,53	h9	186,98	H8/f7	175,53	h9	186,28	H8/f7	175,53	h9	9,5	12,3	15,1	170,82	6,99
441	193,45	H8/f7	182,04	h9	193,45	H8/f7	182,04	h9	192,75	H8/f7	182,04	h9	9,5	12,3	15,1	177,17	6,99
442	200,05	H8/f7	188,64	h9	200,05	H8/f7	188,64	h9	199,35	H8/f7	188,64	h9	9,5	12,3	15,1	183,52	6,99
443	206,53	H8/f7	195,12	h9	206,53	H8/f7	195,12	h9	205,83	H8/f7	195,12	h9	9,5	12,3	15,1	189,87	6,99
444	213,01	H8/f7	201,60	h9	213,01	H8/f7	201,60	h9	212,67	H8/f7	201,60	h9	9,5	12,3	15,1	196,22	6,99
445	219,48	H8/f7	208,07	h9	219,48	H8/f7	208,07	h9	219,15	H8/f7	208,07	h9	9,5	12,3	15,1	202,57	6,99
446	232,70	H8/f7	221,29	h9	232,70	H8/f7	221,29	h9	232,36	H8/f7	221,29	h9	9,5	12,3	15,1	215,27	6,99
447	245,66	H8/f7	234,25	h9	245,66	H8/f7	234,25	h9	245,31	H8/f7	234,25	h9	9,5	12,3	15,1	227,97	6,99
448	258,61	H8/f7	247,20	h9	258,61	H8/f7	247,20	h9	258,26	H8/f7	247,20	h9	9,5	12,3	15,1	240,67	6,99
449	271,57	H8/f7	260,19	h9	271,57	H8/f7	260,19	h9	271,21	H8/f7	260,19	h9	9,5	12,3	15,1	253,37	6,99
450	284,64	H8/f7	273,26	h9	284,64	H8/f7	273,26	h9	284,30	H8/f7	273,26	h9	9,5	12,3	15,1	266,07	6,99
451	297,60	H8/f7	286,22	h9	297,60	H8/f7	286,22	h9	297,25	H8/f7	286,22	h9	9,5	12,3	15,1	278,77	6,99
452	310,55	H8/f7	299,17	h9	310,55	H8/f7	299,17	h9	310,21	H8/f7	299,17	h9	9,5	12,3	15,1	291,47	6,99
453	323,50	H8/f7	312,32	h9	323,50	H8/f7	312,32	h9	323,16	H8/f7	312,32	h9	9,5	12,3	15,1	304,17	6,99
454	336,46	H8/f7	325,12	h9	336,46	H8/f7	325,12	h9	336,01	H8/f7	325,12	h9	9,5	12,3	15,1	316,87	6,99
455	349,41	H8/f7	338,07	h9	349,41	H8/f7	338,07	h9	349,07	H8/f7	338,07	h9	9,5	12,3	15,1	329,57	6,99
456	362,63	H8/f7	351,29	h9	362,63	H8/f7	351,29	h9	362,28	H8/f7	351,29	h9	9,5	12,3	15,1	342,27	6,99
457	375,59	H8/f7	364,25	h9	375,59	H8/f7	364,25	h9	375,23	H8/f7	364,25	h9	9,5	12,3	15,1	354,97	6,99
458	388,54	H8/f7	377,20	h9	388,54	H8/f7	377,20	h9	388,19	H8/f7	377,20	h9	9,5	12,3	15,1	367,67	6,99
459	401,49	H8/f7	390,15	h9	401,49	H8/f7	390,15	h9	401,14	H8/f7	390,15	h9	9,5	12,3	15,1	380,37	6,99
460	414,45	H8/f7	403,15	h9	414,45	H8/f7	403,15	h9	414,09	H8/f7	403,15	h9	9,5	12,3	15,1	393,07	6,99
461	—	—	—	—	—	—	—	—	426,66	H8/f7	415,71	h9	9,5	12,3	15,1	405,26	6,99
462	—	—	—	—	—	—	—	—	439,61	H8/f7	428,67	h9	9,5	12,3	15,1	417,96	6,99
463	—	—	—	—	—	—	—	—	452,70	H8/f7	441,74	h9	9,5	12,3	15,1	430,66	6,99
464	—	—	—	—	—	—	—	—	465,79	H8/f7	454,83	h9	9,5	12,3	15,1	443,36	6,99
465	—	—	—	—	—	—	—	—	478,74	H8/f7	467,78	h9	9,5	12,3	15,1	456,06	6,99
466	—	—	—	—	—	—	—	—	491,69	H8/f7	480,74	h9	9,5	12,3	15,1	468,76	6,99
467	—	—	—	—	—	—	—	—	504,76	H8/f7	493,83	h9	9,5	12,3	15,1	481,46	6,99
468	—	—	—	—	—	—	—	—	517,72	H8/f7	506,82	h9	9,5	12,3	15,1	494,16	6,99
469	—	—	—	—	—	—	—	—	530,80	H8/f7	519,90	h9	9,5	12,3	15,1	506,86	6,99
470	—	—	—	—	—	—	—	—	556,71	H8/f7	545,80	h9	9,5	12,3	15,1	532,26	6,99
471	—	—	—	—	—	—	—	—	582,73	H8/f7	571,84	h9	9,5	12,3	15,1	557,66	6,99
472	—	—	—	—	—	—	—	—	608,39	H8/f7	597,50	h9	9,5	12,3	15,1	582,68	6,99
473	—	—	—	—	—	—	—	—	634,43	H8/f7	623,53	h9	9,5	12,3	15,1	608,08	6,99
474	—	—	—	—	—	—	—	—	660,47	H8/f7	649,61	h9	9,5	12,3	15,1	633,48	6,99
475	—	—	—	—	—	—	—	—	686,51	H8/f7	675,65	h9	9,5	12,3	15,1	658,88	6,99

Table 3 — Basic dimensions of housings for O-rings used in dynamic and static hydraulic and pneumatic piston sealing applications for selected metric bore sizes (see Figure 6)

Dimensions in millimetres

SC	Pneumatic dynamic					Hydraulic dynamic					Static					b ₁	b ₂	b ₃	d ₁	d ₂
	d ₄ /d ₉		d ₃		i ^a	d ₄ /d ₉		d ₃		i ^a	d ₄ /d ₉		d ₃		i ^a					
	nom.	tol.	nom.	tol.		nom.	nom.	tol.	nom.		tol.	nom.	tol.	nom.		tol.	nom.			
014	16	H8/f7	13,2	h9	(1,4)	16	H8/f7	13,2	h9	(1,4)	16	H8/f7	13,4	h9	(1,3)	2,8	4,2	5,6	12,42	1,78
114	20	H8/f7	15,8	h9	(2,1)	20	H8/f7	15,8	h9	(2,1)	20	H8/f7	16,0	h9	(2,0)	3,8	5,2	6,6	15,54	2,62
117 ^b	25	H8/f7	20,8	h9	(2,1)	25	H8/f7	20,8	h9	(2,1)	25	H8/f7	21,0	h9	(2,0)	3,8	5,2	6,6	20,30	2,62
121 ^b	32	H8/f7	27,8	h9	(2,1)	32	H8/f7	27,8	h9	(2,1)	32	H8/f7	28,0	h9	(2,0)	3,8	5,2	6,6	26,64	2,62
126	40	H8/f7	35,8	h9	(2,1)	40	H8/f7	35,8	h9	(2,1)	40	H8/f7	36,0	h9	(2,0)	3,8	5,2	6,6	34,59	2,62
224 ^b	—	—	—	—	—	50	H8/f7	44,4	h9	(2,8)	50	H8/f7	44,6	h9	(2,7)	5,0	6,4	7,8	44,04	3,53
228 ^b	—	—	—	—	—	—	—	—	—	—	63	H8/f7	57,6	h9	(2,7)	5,0	6,4	7,8	56,74	3,53
233 ^b	—	—	—	—	—	80	H8/f7	74,4	h9	(2,8)	80	H8/f7	74,6	h9	(2,7)	5,0	6,4	7,8	72,62	3,53
236	—	—	—	—	—	90	H8/f7	84,4	h9	(2,8)	90	H8/f7	84,6	h9	(2,7)	5,0	6,4	7,8	82,14	3,53
342 ^b	100	H8/f7	90,8	h9	(4,6)	—	—	—	—	—	100	H8/f7	92,0	h9	(4,0)	7,2	9,0	10,9	91,44	5,33
345 ^b	110	H8/f7	100,8	h9	(4,6)	—	—	—	—	—	110	H8/f7	102,0	h9	(4,0)	7,2	9,0	10,9	100,97	5,33
349 ^b	125	H8/f7	115,8	h9	(4,6)	—	—	—	—	—	125	H8/f7	117,0	h9	(4,0)	7,2	9,0	10,9	113,67	5,33
354 ^b	140	H8/f7	130,7	h9	(4,6)	—	—	—	—	—	140	H8/f7	132,0	h9	(4,0)	7,2	9,0	10,9	129,54	5,33
360 ^b	160	H8/f7	150,8	h9	(4,6)	—	—	—	—	—	160	H8/f7	152,0	h9	(4,0)	7,2	9,0	10,9	148,59	5,33
439 ^b	180	H8/f7	168,2	h9	(6,0)	180	H8/f7	168,2	h9	(6,0)	180	H8/f7	168,4	h9	(5,8)	9,5	12,3	15,1	164,47	6,99
442	200	H8/f7	188,2	h9	(6,0)	200	H8/f7	188,2	h9	(6,0)	200	H8/f7	188,4	h9	(5,8)	9,5	12,3	15,1	183,52	6,99
445	220	H8/f7	208,2	h9	(6,0)	220	H8/f7	208,2	h9	(6,0)	220	H8/f7	208,4	h9	(5,8)	9,5	12,3	15,1	202,57	6,99
447	250	H8/f7	238,2	h9	(6,0)	250	H8/f7	238,2	h9	(6,0)	250	H8/f7	238,6	h9	(5,8)	9,5	12,3	15,1	227,97	6,99
450 ^b	280	H8/f7	268,2	h9	(6,0)	280	H8/f7	268,2	h9	(6,0)	280	H8/f7	268,4	h9	(5,8)	9,5	12,3	15,1	266,07	6,99
453 ^b	320	H8/f7	308,2	h9	(6,0)	320	H8/f7	308,2	h9	(6,0)	320	H8/f7	308,4	h9	(5,8)	9,5	12,3	15,1	304,17	6,99
456 ^b	360	H8/f7	348,2	h9	(6,0)	360	H8/f7	348,2	h9	(6,0)	360	H8/f7	348,4	h9	(5,8)	9,5	12,3	15,1	342,27	6,99
459 ^b	400	H8/f7	388,2	h9	(6,0)	400	H8/f7	388,2	h9	(6,0)	400	H8/f7	388,4	h9	(5,8)	9,5	12,3	15,1	380,38	6,99
463 ^b	450	H8/f7	438,2	h9	(6,0)	450	H8/f7	438,2	h9	(6,0)	450	H8/f7	438,4	h9	(5,8)	9,5	12,3	15,1	430,66	6,99
467 ^b	500	H8/f7	488,2	h9	(6,0)	500	H8/f7	488,2	h9	(6,0)	500	H8/f7	488,4	h9	(5,8)	9,5	12,3	15,1	481,46	6,99

^a The *i* value is an additional informative value.

^b While these standard O-rings can be used in the selected metric-bore sizes, their use does not always result in a sealing condition based upon the technical requirements of compression and stretch specified in this part of ISO 3601. To optimize the sealing condition, an O-ring with a non-standard (custom) inside diameter is required; Annex B should be used for guidance in these situations.

CAUTION — Users should evaluate the effect of the maximum eccentricity, *g*, between the bore and the piston on the compression of the O-ring.

Table 4 — Basic dimensions of housings for O-rings used in dynamic and static pneumatic and hydraulic rod sealing applications (see Figure 7)

Dimensions in millimetres

SC	Pneumatic dynamic				Hydraulic dynamic				Static				b ₁	b ₂	b ₃	d ₁	d ₂
	d ₅ /d ₁₀		d ₆		d ₅ /d ₁₀		d ₆		d ₅ /d ₁₀		d ₆						
	nom.	tol.	nom.	tol.	nom.	tol.	nom.	tol.	nom.	tol.	nom.	tol.	nom.	nom.			
004	—	—	—	—	—	—	—	—	1,95	f7/H8	4,56	H9	2,8	4,2	5,6	1,78	1,78
005	—	—	—	—	—	—	—	—	2,76	f7/H8	5,40	H9	2,8	4,2	5,6	2,57	1,78
006	3,16	f7/H8	5,90	H9	3,16	f7/H8	5,85	H9	3,16	f7/H8	5,75	H9	2,8	4,2	5,6	2,90	1,78
007	3,87	f7/H8	6,70	H9	3,87	f7/H8	6,62	H9	3,87	f7/H8	6,50	H9	2,8	4,2	5,6	3,68	1,78
008	4,70	f7/H8	7,46	H9	4,70	f7/H8	7,46	H9	4,70	f7/H8	7,35	H9	2,8	4,2	5,6	4,47	1,78
009	5,50	f7/H8	8,29	H9	5,50	f7/H8	8,29	H9	5,50	f7/H8	8,15	H9	2,8	4,2	5,6	5,28	1,78
010	6,30	f7/H8	9,09	H9	6,30	f7/H8	9,09	H9	6,30	f7/H8	9,00	H9	2,8	4,2	5,6	6,07	1,78
011	8,00	f7/H8	10,78	H9	8,00	f7/H8	10,78	H9	8,00	f7/H8	10,70	H9	2,8	4,2	5,6	7,65	1,78
012	9,50	f7/H8	12,31	H9	9,50	f7/H8	12,31	H9	9,50	f7/H8	12,20	H9	2,8	4,2	5,6	9,25	1,78
013	—	—	—	—	—	—	—	—	11,20	f7/H8	13,90	H9	2,8	4,2	5,6	10,82	1,78
014	—	—	—	—	—	—	—	—	12,80	f7/H8	15,45	H9	2,8	4,2	5,6	12,42	1,78
015	—	—	—	—	—	—	—	—	14,50	f7/H8	17,17	H9	2,8	4,2	5,6	14,00	1,78
016	—	—	—	—	—	—	—	—	16,10	f7/H8	18,70	H9	2,8	4,2	5,6	15,60	1,78
017	—	—	—	—	—	—	—	—	17,60	f7/H8	20,20	H9	2,8	4,2	5,6	17,17	1,78
018	—	—	—	—	—	—	—	—	19,30	f7/H8	21,88	H9	2,8	4,2	5,6	18,77	1,78
019	—	—	—	—	—	—	—	—	21,00	f7/H8	23,46	H9	2,8	4,2	5,6	20,35	1,78
020	—	—	—	—	—	—	—	—	22,50	f7/H8	25,05	H9	2,8	4,2	5,6	21,95	1,78
021	—	—	—	—	—	—	—	—	24,10	f7/H8	26,62	H9	2,8	4,2	5,6	23,52	1,78
022	—	—	—	—	—	—	—	—	25,70	f7/H8	28,20	H9	2,8	4,2	5,6	25,12	1,78
023	—	—	—	—	—	—	—	—	27,30	f7/H8	29,78	H9	2,8	4,2	5,6	26,70	1,78
024	—	—	—	—	—	—	—	—	29,00	f7/H8	31,38	H9	2,8	4,2	5,6	28,30	1,78
025	—	—	—	—	—	—	—	—	30,50	f7/H8	32,92	H9	2,8	4,2	5,6	29,87	1,78
026	—	—	—	—	—	—	—	—	32,15	f7/H8	34,52	H9	2,8	4,2	5,6	31,47	1,78
027	—	—	—	—	—	—	—	—	33,70	f7/H8	36,10	H9	2,8	4,2	5,6	33,05	1,78
102	—	—	—	—	—	—	—	—	1,40	f7/H8	5,23	H9	3,8	5,2	6,6	1,24	2,62
103	—	—	—	—	—	—	—	—	2,23	f7/H8	6,24	H9	3,8	5,2	6,6	2,06	2,62
104	3,03	f7/H8	7,16	H9	3,03	f7/H8	7,16	H9	3,03	f7/H8	7,00	H9	3,8	5,2	6,6	2,84	2,62
105	3,85	f7/H8	8,02	H9	3,85	f7/H8	8,02	H9	3,85	f7/H8	7,80	H9	3,8	5,2	6,6	3,63	2,62
106	4,65	f7/H8	8,85	H9	4,65	f7/H8	8,85	H9	4,65	f7/H8	8,80	H9	3,8	5,2	6,6	4,42	2,62
107	5,50	f7/H8	9,72	H9	5,50	f7/H8	9,72	H9	5,50	f7/H8	9,60	H9	3,8	5,2	6,6	5,23	2,62
108	6,30	f7/H8	10,53	H9	6,30	f7/H8	10,53	H9	6,30	f7/H8	10,40	H9	3,8	5,2	6,6	6,02	2,62
109	8,00	f7/H8	12,22	H9	8,00	f7/H8	12,22	H9	8,00	f7/H8	12,00	H9	3,8	5,2	6,6	7,59	2,62
110	9,50	f7/H8	13,97	H9	9,50	f7/H8	13,75	H9	9,50	f7/H8	13,60	H9	3,8	5,2	6,6	9,19	2,62
111	11,20	f7/H8	15,60	H9	11,20	f7/H8	15,46	H9	11,20	f7/H8	15,30	H9	3,8	5,2	6,6	10,77	2,62
112	12,80	f7/H8	17,00	H9	12,80	f7/H8	17,00	H9	12,80	f7/H8	16,90	H9	3,8	5,2	6,6	12,37	2,62
113	14,50	f7/H8	18,70	H9	14,50	f7/H8	18,70	H9	14,50	f7/H8	18,60	H9	3,8	5,2	6,6	13,94	2,62
114	16,00	f7/H8	20,25	H9	16,00	f7/H8	20,25	H9	16,00	f7/H8	20,10	H9	3,8	5,2	6,6	15,54	2,62

Table 4 (continued)

SC	Pneumatic dynamic				Hydraulic dynamic				Static				b ₁	b ₂	b ₃	d ₁	d ₂
	d ₅ /d ₁₀		d ₆		d ₅ /d ₁₀		d ₆		d ₅ /d ₁₀		d ₆						
	nom.	tol.	nom.	tol.	nom.	tol.	nom.	tol.	nom.	tol.	nom.	tol.	nom.	nom.			
115	17,70	f7/H8	21,90	H9	17,70	f7/H8	21,90	H9	17,70	f7/H8	21,70	H9	3,8	5,2	6,6	17,12	2,62
116	19,30	f7/H8	23,50	H9	19,30	f7/H8	23,50	H9	19,30	f7/H8	23,40	H9	3,8	5,2	6,6	18,72	2,62
117	—	—	—	—	—	—	—	—	21,00	f7/H8	25,00	H9	3,8	5,2	6,6	20,30	2,62
118	—	—	—	—	—	—	—	—	22,50	f7/H8	26,60	H9	3,8	5,2	6,6	21,89	2,62
119	—	—	—	—	—	—	—	—	24,00	f7/H8	28,00	H9	3,8	5,2	6,6	23,47	2,62
120	—	—	—	—	—	—	—	—	25,70	f7/H8	29,80	H9	3,8	5,2	6,6	25,07	2,62
121	—	—	—	—	—	—	—	—	27,30	f7/H8	31,40	H9	3,8	5,2	6,6	26,64	2,62
122	—	—	—	—	—	—	—	—	29,00	f7/H8	33,00	H9	3,8	5,2	6,6	28,24	2,62
123	—	—	—	—	—	—	—	—	30,50	f7/H8	34,50	H9	3,8	5,2	6,6	29,82	2,62
124	—	—	—	—	—	—	—	—	32,10	f7/H8	36,10	H9	3,8	5,2	6,6	31,42	2,62
125	—	—	—	—	—	—	—	—	34,00	f7/H8	37,70	H9	3,8	5,2	6,6	32,99	2,62
126	—	—	—	—	—	—	—	—	35,50	f7/H8	39,30	H9	3,8	5,2	6,6	34,59	2,62
127	—	—	—	—	—	—	—	—	37,00	f7/H8	40,88	H9	3,8	5,2	6,6	36,17	2,62
128	—	—	—	—	—	—	—	—	38,50	f7/H8	42,40	H9	3,8	5,2	6,6	37,77	2,62
129	—	—	—	—	—	—	—	—	40,20	f7/H8	43,90	H9	3,8	5,2	6,6	39,34	2,62
130	—	—	—	—	—	—	—	—	41,80	f7/H8	45,50	H9	3,8	5,2	6,6	40,94	2,62
131	—	—	—	—	—	—	—	—	43,40	f7/H8	47,10	H9	3,8	5,2	6,6	42,52	2,62
132	—	—	—	—	—	—	—	—	45,00	f7/H8	48,70	H9	3,8	5,2	6,6	44,12	2,62
133	—	—	—	—	—	—	—	—	46,60	f7/H8	50,30	H9	3,8	5,2	6,6	45,69	2,62
134	—	—	—	—	—	—	—	—	48,20	f7/H8	51,90	H9	3,8	5,2	6,6	47,29	2,62
201	—	—	—	—	—	—	—	—	4,56	f7/H8	10,19	H9	5,0	6,4	7,8	4,34	3,53
202	—	—	—	—	—	—	—	—	6,20	f7/H8	11,85	H9	5,0	6,4	7,8	5,94	3,53
203	—	—	—	—	—	—	—	—	7,80	f7/H8	13,51	H9	5,0	6,4	7,8	7,52	3,53
204	—	—	—	—	—	—	—	—	9,40	f7/H8	15,10	H9	5,0	6,4	7,8	9,12	3,53
205	—	—	—	—	—	—	—	—	11,00	f7/H8	16,50	H9	5,0	6,4	7,8	10,69	3,53
206	—	—	—	—	—	—	—	—	12,70	f7/H8	18,20	H9	5,0	6,4	7,8	12,29	3,53
207	—	—	—	—	—	—	—	—	14,30	f7/H8	19,80	H9	5,0	6,4	7,8	13,87	3,53
208	—	—	—	—	—	—	—	—	16,00	f7/H8	21,50	H9	5,0	6,4	7,8	15,47	3,53
209	—	—	—	—	—	—	—	—	17,50	f7/H8	23,00	H9	5,0	6,4	7,8	17,04	3,53
210	19,30	f7/H8	25,00	H9	19,30	f7/H8	25,00	H9	19,30	f7/H8	24,80	H9	5,0	6,4	7,8	18,64	3,53
211	21,00	f7/H8	26,70	H9	21,00	f7/H8	26,70	H9	21,00	f7/H8	26,50	H9	5,0	6,4	7,8	20,22	3,53
212	22,50	f7/H8	28,48	H9	22,50	f7/H8	28,48	H9	22,50	f7/H8	27,97	H9	5,0	6,4	7,8	21,82	3,53
213	24,10	f7/H8	29,90	H9	24,10	f7/H8	29,90	H9	24,10	f7/H8	29,60	H9	5,0	6,4	7,8	23,39	3,53
214	25,70	f7/H8	31,50	H9	25,70	f7/H8	31,50	H9	25,70	f7/H8	31,20	H9	5,0	6,4	7,8	24,99	3,53
215	27,20	f7/H8	32,90	H9	27,20	f7/H8	32,90	H9	27,20	f7/H8	32,70	H9	5,0	6,4	7,8	26,57	3,53
216	28,80	f7/H8	34,60	H9	28,80	f7/H8	34,60	H9	28,80	f7/H8	34,30	H9	5,0	6,4	7,8	28,17	3,53
217	30,40	f7/H8	36,20	H9	30,40	f7/H8	36,20	H9	30,40	f7/H8	35,85	H9	5,0	6,4	7,8	29,74	3,53
218	32,00	f7/H8	37,80	H9	32,00	f7/H8	37,80	H9	32,00	f7/H8	37,45	H9	5,0	6,4	7,8	31,34	3,53
219	33,60	f7/H8	39,40	H9	33,60	f7/H8	39,40	H9	33,60	f7/H8	39,10	H9	5,0	6,4	7,8	32,92	3,53

Table 4 (continued)

SC	Pneumatic dynamic				Hydraulic dynamic				Static				b ₁	b ₂	b ₃	d ₁	d ₂
	d ₅ /d ₁₀		d ₆		d ₅ /d ₁₀		d ₆		d ₅ /d ₁₀		d ₆						
	nom.	tol.	nom.	tol.	nom.	tol.	nom.	tol.	nom.	tol.	nom.	tol.	nom.	nom.			
220	35,30	f7/H8	41,00	H9	35,30	f7/H8	41,00	H9	35,30	f7/H8	40,65	H9	5,0	6,4	7,8	34,52	3,53
221	36,80	f7/H8	42,50	H9	36,80	f7/H8	42,50	H9	36,80	f7/H8	42,20	H9	5,0	6,4	7,8	36,09	3,53
222	—	—	—	—	38,50	f7/H8	44,10	H9	38,50	f7/H8	43,85	H9	5,0	6,4	7,8	37,69	3,53
223	—	—	—	—	—	—	—	—	42,00	f7/H8	47,28	H9	5,0	6,4	7,8	40,87	3,53
224	—	—	—	—	—	—	—	—	45,00	f7/H8	50,40	H9	5,0	6,4	7,8	44,04	3,53
225	—	—	—	—	—	—	—	—	48,20	f7/H8	53,54	H9	5,0	6,4	7,8	47,22	3,53
226	—	—	—	—	—	—	—	—	51,50	f7/H8	56,70	H9	5,0	6,4	7,8	50,39	3,53
227	—	—	—	—	—	—	—	—	54,70	f7/H8	59,89	H9	5,0	6,4	7,8	53,57	3,53
228	—	—	—	—	—	—	—	—	58,00	f7/H8	63,00	H9	5,0	6,4	7,8	56,74	3,53
229	—	—	—	—	—	—	—	—	61,10	f7/H8	66,19	H9	5,0	6,4	7,8	59,92	3,53
230	—	—	—	—	—	—	—	—	64,30	f7/H8	69,36	H9	5,0	6,4	7,8	63,09	3,53
231	—	—	—	—	—	—	—	—	67,50	f7/H8	72,54	H9	5,0	6,4	7,8	66,27	3,53
309	—	—	—	—	—	—	—	—	10,80	f7/H8	19,50	H9	7,2	9,0	10,9	10,46	5,33
310	—	—	—	—	—	—	—	—	12,50	f7/H8	21,30	H9	7,2	9,0	10,9	12,07	5,33
311	—	—	—	—	—	—	—	—	14,10	f7/H8	22,90	H9	7,2	9,0	10,9	13,64	5,33
312	—	—	—	—	—	—	—	—	15,70	f7/H8	24,50	H9	7,2	9,0	10,9	15,24	5,33
313	—	—	—	—	—	—	—	—	17,50	f7/H8	26,10	H9	7,2	9,0	10,9	16,81	5,33
314	—	—	—	—	—	—	—	—	19,00	f7/H8	27,50	H9	7,2	9,0	10,9	18,42	5,33
315	—	—	—	—	—	—	—	—	20,50	f7/H8	29,00	H9	7,2	9,0	10,9	19,99	5,33
316	—	—	—	—	—	—	—	—	22,53	f7/H8	31,29	H9	7,2	9,0	10,9	21,59	5,33
317	—	—	—	—	—	—	—	—	24,00	f7/H8	32,80	H9	7,2	9,0	10,9	23,16	5,33
318	—	—	—	—	—	—	—	—	25,50	f7/H8	34,30	H9	7,2	9,0	10,9	24,77	5,33
319	—	—	—	—	—	—	—	—	27,00	f7/H8	35,80	H9	7,2	9,0	10,9	26,34	5,33
320	—	—	—	—	—	—	—	—	29,00	f7/H8	37,50	H9	7,2	9,0	10,9	27,94	5,33
321	—	—	—	—	—	—	—	—	30,50	f7/H8	39,00	H9	7,2	9,0	10,9	29,51	5,33
322	—	—	—	—	—	—	—	—	32,00	f7/H8	40,50	H9	7,2	9,0	10,9	31,12	5,33
323	—	—	—	—	—	—	—	—	33,50	f7/H8	42,00	H9	7,2	9,0	10,9	32,69	5,33
324	—	—	—	—	—	—	—	—	35,00	f7/H8	43,50	H9	7,2	9,0	10,9	34,29	5,33
325	38,50	f7/H8	47,40	H9	38,50	f7/H8	47,40	H9	38,50	f7/H8	46,80	H9	7,2	9,0	10,9	37,47	5,33
326	41,50	f7/H8	50,40	H9	41,50	f7/H8	50,40	H9	41,50	f7/H8	49,80	H9	7,2	9,0	10,9	40,64	5,33
327	45,00	f7/H8	53,75	H9	45,00	f7/H8	53,75	H9	45,00	f7/H8	53,30	H9	7,2	9,0	10,9	43,82	5,33
328	48,00	f7/H8	56,90	H9	48,00	f7/H8	56,90	H9	48,00	f7/H8	56,30	H9	7,2	9,0	10,9	46,99	5,33
329	51,20	f7/H8	60,00	H9	51,20	f7/H8	60,00	H9	51,20	f7/H8	59,50	H9	7,2	9,0	10,9	50,17	5,33
330	54,40	f7/H8	63,20	H9	54,40	f7/H8	63,20	H9	54,40	f7/H8	62,70	H9	7,2	9,0	10,9	53,34	5,33
331	57,55	f7/H8	66,38	H9	57,55	f7/H8	66,38	H9	57,55	f7/H8	65,90	H9	7,2	9,0	10,9	56,52	5,33
332	—	—	—	—	61,00	f7/H8	69,55	H9	61,00	f7/H8	69,30	H9	7,2	9,0	10,9	59,69	5,33
333	—	—	—	—	64,10	f7/H8	72,68	H9	64,10	f7/H8	72,40	H9	7,2	9,0	10,9	62,87	5,33
334	—	—	—	—	67,25	f7/H8	75,85	H9	67,25	f7/H8	75,60	H9	7,2	9,0	10,9	66,04	5,33

Table 4 (continued)

SC	Pneumatic dynamic				Hydraulic dynamic				Static				b_1	b_2	b_3	d_1	d_2
	d_5/d_{10}		d_6		d_5/d_{10}		d_6		d_5/d_{10}		d_6		+0,25 0			nom.	nom.
	nom.	tol.	nom.	tol.	nom.	tol.	nom.	tol.	nom.	tol.	nom.	tol.					
335	—	—	—	—	70,40	f7/H8	79,00	H9	70,40	f7/H8	78,70	H9	7,2	9,0	10,9	69,22	5,33
336	—	—	—	—	73,61	f7/H8	82,19	H9	73,61	f7/H8	81,90	H9	7,2	9,0	10,9	72,39	5,33
337	—	—	—	—	—	—	—	—	77,00	f7/H8	85,25	H9	7,2	9,0	10,9	75,57	5,33
338	—	—	—	—	—	—	—	—	80,20	f7/H8	88,42	H9	7,2	9,0	10,9	78,74	5,33
339	—	—	—	—	—	—	—	—	83,50	f7/H8	91,60	H9	7,2	9,0	10,9	81,92	5,33
340	—	—	—	—	—	—	—	—	86,60	f7/H8	94,75	H9	7,2	9,0	10,9	85,09	5,33
341	—	—	—	—	—	—	—	—	90,00	f7/H8	97,97	H9	7,2	9,0	10,9	88,27	5,33
342	—	—	—	—	—	—	—	—	93,10	f7/H8	101,04	H9	7,2	9,0	10,9	91,44	5,33
343	—	—	—	—	—	—	—	—	96,40	f7/H8	104,22	H9	7,2	9,0	10,9	94,62	5,33
344	—	—	—	—	—	—	—	—	99,60	f7/H8	107,39	H9	7,2	9,0	10,9	97,79	5,33
345	—	—	—	—	—	—	—	—	102,80	f7/H8	110,57	H9	7,2	9,0	10,9	100,97	5,33
346	—	—	—	—	—	—	—	—	106,00	f7/H8	113,74	H9	7,2	9,0	10,9	104,14	5,33
347	—	—	—	—	—	—	—	—	109,15	f7/H8	116,87	H9	7,2	9,0	10,9	107,32	5,33
348	—	—	—	—	—	—	—	—	112,30	f7/H8	120,03	H9	7,2	9,0	10,9	110,49	5,33
349	—	—	—	—	—	—	—	—	115,50	f7/H8	123,21	H9	7,2	9,0	10,9	113,67	5,33
425	—	—	—	—	—	—	—	—	115,70	f7/H8	126,40	H9	9,5	12,3	15,1	113,67	6,99
426	—	—	—	—	—	—	—	—	119,00	f7/H8	129,58	H9	9,5	12,3	15,1	116,84	6,99
427	—	—	—	—	—	—	—	—	122,00	f7/H8	132,76	H9	9,5	12,3	15,1	120,02	6,99
428	—	—	—	—	—	—	—	—	125,30	f7/H8	135,93	H9	9,5	12,3	15,1	123,19	6,99
429	—	—	—	—	—	—	—	—	128,50	f7/H8	139,01	H9	9,5	12,3	15,1	126,37	6,99

Table 5 — Basic dimensions of housings for O-rings used in dynamic and static pneumatic and hydraulic rod sealing applications for selected metric rod sizes (see Figure 7)

Dimensions in millimetres

SC	Pneumatic dynamic					Hydraulic dynamic					Static					b ₁	b ₂	b ₃	d ₁	d ₂
	d ₅ /d ₁₀		d ₆		t ^a	d ₅ /d ₁₀		d ₆		t ^a	d ₅ /d ₁₀		d ₆		t ^a					
	nom.	tol.	nom.	tol.		nom.	nom.	tol.	nom.		tol.	nom.	tol.	nom.		tol.	nom.			
010	6	H8/f7	8,8	H9	(1,4)	6	H8/f7	8,8	H9	(1,4)	6	H8/f7	8,8	H9	(1,4)	2,8	4,2	5,6	6,07	1,78
011	—	—	—	—	—	8	H8/f7	10,7	H9	(1,4)	8	H8/f7	10,7	H9	(1,4)	2,8	4,2	5,6	7,65	1,78
013	10	H8/f7	12,8	H9	(1,4)	10	H8/f7	12,8	H9	(1,4)	10	H8/f7	12,8	H9	(1,4)	2,8	4,2	5,6	10,92	1,78
014	12	H8/f7	14,8	H9	(1,4)	12	H8/f7	14,8	H9	(1,4)	12	H8/f7	14,8	H9	(1,4)	2,8	4,2	5,6	12,42	1,78
015	14	H8/f7	16,8	H9	(1,4)	14	H8/f7	16,8	H9	(1,4)	14	H8/f7	16,8	H9	(1,4)	2,8	4,2	5,6	14,00	1,78
016	—	—	—	—	—	16	H8/f7	18,7	H9	(1,4)	16	H8/f7	18,7	H9	(1,4)	2,8	4,2	5,6	15,60	1,78
018	18	H8/f7	20,8	H9	(1,4)	18	H8/f7	20,8	H9	(1,4)	18	H8/f7	20,8	H9	(1,4)	2,8	4,2	5,6	18,77	1,78
117 ^b	20	H8/f7	24,2	H9	(2,1)	20	H8/f7	24,2	H9	(2,1)	20	H8/f7	24,0	H9	(2,0)	3,8	5,2	6,6	20,30	2,62
118 ^b	22	H8/f7	26,2	H9	(2,1)	22	H8/f7	26,2	H9	(2,1)	22	H8/f7	26,0	H9	(2,0)	3,8	5,2	6,6	21,89	2,62
120 ^b	25	H8/f7	29,2	H9	(2,1)	25	H8/f7	29,2	H9	(2,1)	25	H8/f7	29,0	H9	(2,0)	3,8	5,2	6,6	25,07	2,62
122 ^b	28	H8/f7	32,2	H9	(2,1)	28	H8/f7	32,2	H9	(2,1)	28	H8/f7	32,0	H9	(2,0)	3,8	5,2	6,6	28,24	2,62
125 ^b	32	H8/f7	36,2	H9	(2,1)	32	H8/f7	36,2	H9	(2,1)	32	H8/f7	36,0	H9	(2,0)	3,8	5,2	6,6	32,99	2,62
221 ^b	—	—	—	—	—	—	—	—	—	—	36	H8/f7	41,4	H9	(2,7)	5,0	6,4	7,8	36,09	3,53
223 ^b	—	—	—	—	—	—	—	—	—	—	40	H8/f7	45,4	H9	(2,7)	5,0	6,4	7,8	40,87	3,53
224 ^b	—	—	—	—	—	45	H8/f7	50,6	H9	(2,8)	45	H8/f7	50,4	H9	(2,7)	5,0	6,4	7,8	44,04	3,53
329 ^b	50	H8/f7	59,1	H9	(4,6)	50	H8/f7	59,1	H9	(4,6)	50	H8/f7	58,0	H9	(4,0)	7,2	9,0	10,9	50,17	5,33
331 ^b	56	H8/f7	65,2	H9	(4,6)	—	—	—	—	—	56	H8/f7	64,0	H9	(4,0)	7,2	9,0	10,9	56,52	5,33
333 ^b	63	H8/f7	72,1	H9	(4,6)	63	H8/f7	72,1	H9	(4,6)	63	H8/f7	71,0	H9	(4,0)	7,2	9,0	10,9	62,87	5,33
335 ^b	70	H8/f7	79,1	H9	(4,6)	70	H8/f7	79,1	H9	(4,6)	70	H8/f7	78,0	H9	(4,0)	7,2	9,0	10,9	69,22	5,33
339 ^b	80	H8/f7	89,1	H9	(4,6)	80	H8/f7	89,1	H9	(4,6)	80	H8/f7	88,0	H9	(4,0)	7,2	9,0	10,9	81,92	5,33
342 ^b	90	H8/f7	99,1	H9	(4,6)	90	H8/f7	99,1	H9	(4,6)	90	H8/f7	98,0	H9	(4,0)	7,2	9,0	10,9	91,44	5,33
345 ^b	100	H8/f7	109,1	H9	(4,6)	100	H8/f7	109,1	H9	(4,6)	100	H8/f7	108,0	H9	(4,0)	7,2	9,0	10,9	100,97	5,33
348 ^b	110	H8/f7	119,1	H9	(4,6)	110	H8/f7	119,1	H9	(4,6)	110	H8/f7	118,0	H9	(4,0)	7,2	9,0	10,9	110,49	5,33
429 ^b	125	H8/f7	136,8	H9	(6,0)	125	H8/f7	136,8	H9	(6,0)	125	H8/f7	136,6	H9	(5,8)	9,5	12,3	15,1	126,37	6,99
433 ^b	140	H8/f7	151,8	H9	(6,0)	140	H8/f7	151,8	H9	(6,0)	140	H8/f7	151,6	H9	(5,8)	9,5	12,3	15,1	139,07	6,99
438 ^b	160	H8/f7	171,8	H9	(6,0)	160	H8/f7	171,8	H9	(6,0)	160	H8/f7	171,6	H9	(5,8)	9,5	12,3	15,1	158,12	6,99
442 ^b	180	H8/f7	191,8	H9	(6,0)	180	H8/f7	191,8	H9	(6,0)	180	H8/f7	191,6	H9	(5,8)	9,5	12,3	15,1	183,52	6,99
445 ^b	200	H8/f7	211,8	H9	(6,0)	200	H8/f7	211,8	H9	(6,0)	200	H8/f7	211,6	H9	(5,8)	9,5	12,3	15,1	202,57	6,99
447 ^b	220	H8/f7	231,8	H9	(6,0)	220	H8/f7	231,8	H9	(6,0)	220	H8/f7	231,6	H9	(5,8)	9,5	12,3	15,1	227,97	6,99
449 ^b	250	H8/f7	261,8	H9	(6,0)	250	H8/f7	261,8	H9	(6,0)	250	H8/f7	261,6	H9	(5,8)	9,5	12,3	15,1	253,37	6,99
451 ^b	280	H8/f7	291,8	H9	(6,0)	280	H8/f7	291,8	H9	(6,0)	280	H8/f7	291,6	H9	(5,8)	9,5	12,3	15,1	278,77	6,99
455 ^b	320	H8/f7	331,8	H9	(6,0)	320	H8/f7	331,8	H9	(6,0)	320	H8/f7	331,6	H9	(5,8)	9,5	12,3	15,1	329,57	6,99
458 ^b	360	H8/f7	371,8	H9	(6,0)	360	H8/f7	371,8	H9	(6,0)	360	H8/f7	371,6	H9	(5,8)	9,5	12,3	15,1	367,67	6,99

^a The *t* value is an additional informative value.

^b While these standard O-rings can be used in the selected metric bore sizes, their use does not always result in a sealing condition based upon the technical requirements of compression and stretch specified in this part of ISO 3601. To optimize the sealing condition, an O-ring with a non-standard (custom) inside diameter would be required; Annex B should be used for guidance in these situations.

CAUTION — Users should evaluate the effect of the maximum eccentricity, *g*, between the bore and the rod on the compression of the O-ring.

Table 6 — Detail dimensions of housings for O-rings for use in hydraulic and pneumatic static axial sealing applications (see Figure 4)

Dimensions in millimetres unless otherwise noted

d_2	b_4		h	f	Surface roughness values ^{a, b, c, d}	
	Housing width: liquid applications	Housing width: gas or vacuum applications			Side surface a	Inside surface c
nom.						
		$+0,2$ 0				
1,78	3,2	2,9	1,3	+0,4	Ra 1,6 μm visual inspection or Rz 6,3 μm visual inspection	Ra1 1,6 μm Rz1 6,3 μm
2,62	4,0	3,6	2,0	+0,2		Ra2 1,6 μm Rz2 6,3 μm
3,53	5,3	4,8	2,7	+0,8	Ra1 1,6 μm Rz1 6,3 μm	Ra3 1,6 μm Rz3 6,3 μm
5,33	7,6	7,0	4,2	+0,4	Ra3 1,6 μm Rz3 6,3 μm	Ra 1,6 μm Rz 6,3 μm
6,99	9,0	8,5	5,7	+1,2 +0,8	Ra4 1,6 μm Rz4 6,3 μm	Ra 1,6 μm Rz 6,3 μm
<p>^a Indication of surface roughness in accordance with ISO 1302.</p> <p>^b Special applications may require different surface roughness values.</p> <p>^c The descriptions of Ra1 1,6 or Rz1 6,3 do not describe a surface roughness of Ra 11,6 or Rz 16,3. According to ISO 1302 they show only a single measuring length and the roughness does not exceed 1,6 μm for Ra and 6,3 μm for Rz. A value of Ra 1,6 or Rz 6,3 can be measured only if the measuring length is longer than 5,6 mm.</p> <p>^d Visual surface imperfections are not allowed on surface c (see ISO 8785).</p>						

Table 7 — Basic dimensions of housings for O-rings for use in hydraulic and pneumatic static axial sealing applications (see Figure 4 and 6.1.3.1)

Dimensions in millimetres

SC	Internal pressure		External pressure		d_1	d_2
	d_7		d_8			
	nom.	tol.	nom.	tol.	nom.	nom.
004	5,33	H9	1,80	h9	1,78	1,78
005	6,12	H9	2,59	h9	2,57	1,78
006	6,45	H9	2,92	h9	2,90	1,78
007	7,24	H9	3,71	h9	3,68	1,78
008	8,03	H9	4,50	h9	4,47	1,78
009	8,84	H9	5,33	h9	5,28	1,78
010	9,63	H9	6,12	h9	6,07	1,78
011	11,20	H9	7,72	h9	7,65	1,78
012	12,80	H9	9,32	h9	9,25	1,78
013	14,38	H9	10,92	h9	10,82	1,78
014	15,98	H9	12,55	h9	12,42	1,78
015	17,55	H9	14,15	h9	14,00	1,78
016	19,15	H9	15,75	h9	15,60	1,78
017	20,73	H9	17,30	h9	17,17	1,78
018	22,33	H9	18,90	h9	18,77	1,78
019	23,90	H9	20,47	h9	20,35	1,78
020	25,50	H9	22,07	h9	21,95	1,78
021	27,08	H9	23,75	h9	23,52	1,78
022	28,68	H9	25,37	h9	25,12	1,78
023	30,25	H9	26,97	h9	26,70	1,78
024	31,85	H9	28,58	h9	28,30	1,78
025	33,43	H9	30,18	h9	29,87	1,78
026	35,03	H9	31,78	h9	31,47	1,78
027	36,60	H9	33,38	h9	33,05	1,78
028	38,20	H9	35,00	h9	34,65	1,78
029	41,38	H9	38,20	h9	37,62	1,78
030	44,55	H9	41,40	h9	41,00	1,78
031	47,73	H9	44,60	h9	44,17	1,78
032	50,90	H9	47,83	h9	47,35	1,78
033	54,08	H9	51,03	h9	50,52	1,78
034	57,25	H9	54,23	h9	53,70	1,78
035	60,43	H9	57,43	h9	56,87	1,78
036	63,60	H9	60,66	h9	60,05	1,78

SC	Internal pressure		External pressure		d_1	d_2
	d_7		d_8			
	nom.	tol.	nom.	tol.	nom.	nom.
037	66,78	H9	63,86	h9	63,22	1,78
038	69,95	H9	67,06	h9	66,40	1,78
039	73,13	H9	70,26	h9	69,57	1,78
040	76,30	H9	73,48	h9	72,75	1,78
041	79,48	H9	76,68	h9	75,92	1,78
042	85,83	H9	83,08	h9	82,27	1,78
043	92,18	H9	89,51	h9	88,62	1,78
044	96,53	H9	95,91	h9	94,97	1,78
045	104,87	H9	102,33	h9	101,32	1,78
046	111,22	H9	108,73	h9	107,67	1,78
047	117,57	H9	115,16	h9	114,02	1,78
048	123,92	H9	121,56	h9	120,37	1,78
049	130,27	H9	127,99	h9	126,72	1,78
050	136,62	H9	134,39	h9	133,07	1,78
102	6,48	H9	1,27	h9	1,24	2,62
103	7,29	H9	2,08	h9	2,06	2,62
104	8,08	H9	2,87	h9	2,84	2,62
105	8,86	H9	3,66	h9	3,63	2,62
106	9,65	H9	4,47	h9	4,42	2,62
107	10,46	H9	5,28	h9	5,23	2,62
108	11,25	H9	6,07	h9	6,02	2,62
109	12,83	H9	7,67	h9	7,59	2,62
110	14,43	H9	9,27	h9	9,19	2,62
111	16,00	H9	10,87	h9	10,77	2,62
112	17,60	H9	12,50	h9	12,37	2,62
113	19,18	H9	14,07	h9	13,94	2,62
114	20,78	H9	15,68	h9	15,54	2,62
115	22,35	H9	17,30	h9	17,12	2,62
116	23,95	H9	18,90	h9	18,72	2,62
117	25,53	H9	20,50	h9	20,29	2,62
118	27,13	H9	22,12	h9	21,89	2,62
119	28,70	H9	23,70	h9	23,47	2,62
120	30,30	H9	25,30	h9	25,07	2,62

SC	Internal pressure		External pressure		d_1	d_2
	d_7		d_8			
	nom.	tol.	nom.	tol.	nom.	nom.
121	31,88	H9	26,90	h9	26,64	2,62
122	33,48	H9	28,52	h9	28,24	2,62
123	35,05	H9	30,12	h9	29,82	2,62
124	36,65	H9	31,98	h9	31,42	2,62
125	38,23	H9	33,32	h9	32,99	2,62
126	39,83	H9	34,95	h9	34,59	2,62
127	41,40	H9	36,53	h9	36,17	2,62
128	43,00	H9	38,15	h9	37,77	2,62
129	44,58	H9	39,73	h9	39,34	2,62
130	46,18	H9	41,35	h9	40,94	2,62
131	47,75	H9	41,95	h9	42,52	2,62
132	49,35	H9	44,55	h9	44,12	2,62
133	50,93	H9	46,15	h9	45,69	2,62
134	52,53	H9	47,78	h9	47,29	2,62
135	54,13	H9	49,38	h9	48,90	2,62
136	55,70	H9	50,98	h9	50,47	2,62
137	57,30	H9	52,60	h9	52,07	2,62
138	58,88	H9	54,18	h9	53,64	2,62
139	60,48	H9	55,80	h9	55,25	2,62
140	62,05	H9	57,38	h9	56,82	2,62
141	63,65	H9	59,00	h9	58,42	2,62
142	65,23	H9	60,60	h9	59,99	2,62
143	66,83	H9	62,20	h9	61,60	2,62
144	68,40	H9	63,80	h9	63,17	2,62
145	70,00	H9	65,43	h9	64,77	2,62
146	71,58	H9	67,05	h9	66,34	2,62
147	73,18	H9	68,63	h9	67,95	2,62
148	74,75	H9	70,21	h9	69,52	2,62
149	76,35	H9	71,83	h9	71,12	2,62
150	77,93	H9	73,43	h9	72,69	2,62
151	81,10	H9	76,63	h9	75,87	2,62
152	87,45	H9	83,03	h9	82,22	2,62
153	93,80	H9	89,46	h9	88,57	2,62
154	100,15	H9	95,86	h9	94,92	2,62
155	106,50	H9	102,28	h9	101,27	2,62
156	112,85	H9	108,68	h9	107,62	2,62
157	119,20	H9	115,11	h9	113,97	2,62

SC	Internal pressure		External pressure		d_1	d_2
	d_7		d_8			
	nom.	tol.	nom.	tol.	nom.	nom.
158	125,55	H9	121,51	h9	120,32	2,62
159	131,90	H9	127,94	h9	126,67	2,62
160	138,25	H9	134,34	h9	133,02	2,62
161	144,60	H9	140,76	h9	139,37	2,62
162	150,95	H9	147,16	h9	145,72	2,62
163	157,30	H9	153,59	h9	152,07	2,62
164	163,65	H9	159,94	h9	158,42	2,62
165	170,00	H9	166,29	h9	164,77	2,62
166	176,35	H9	172,64	h9	171,12	2,62
167	182,70	H9	178,99	h9	177,47	2,62
168	189,05	H9	185,34	h9	183,82	2,62
169	195,40	H9	191,69	h9	190,17	2,62
170	201,75	H9	198,04	h9	196,52	2,62
171	208,10	H9	204,39	h9	202,87	2,62
172	214,45	H9	210,74	h9	209,22	2,62
173	220,80	H9	217,09	h9	215,57	2,62
174	227,15	H9	223,44	h9	221,92	2,62
175	233,50	H9	229,79	h9	228,27	2,62
176	239,85	H9	236,14	h9	234,62	2,62
177	246,20	H9	242,54	h9	240,97	2,62
178	252,55	H9	248,84	h9	247,32	2,62
201	11,40	H9	4,39	h9	4,34	3,53
202	13,00	H9	5,99	h9	5,94	3,53
203	14,58	H9	7,59	h9	7,52	3,53
204	16,18	H9	9,22	h9	9,12	3,53
205	17,75	H9	10,80	h9	10,69	3,53
206	19,35	H9	12,42	h9	12,29	3,53
207	20,93	H9	14,00	h9	13,87	3,53
208	22,53	H9	15,62	h9	15,47	3,53
209	24,10	H9	17,20	h9	17,04	3,53
210	25,70	H9	18,82	h9	18,64	3,53
211	27,28	H9	20,42	h9	20,22	3,53
212	28,88	H9	22,05	h9	21,82	3,53
213	30,45	H9	23,62	h9	23,39	3,53
214	32,05	H9	25,25	h9	24,99	3,53
215	33,63	H9	26,82	h9	26,57	3,53
216	35,23	H9	28,45	h9	28,17	3,53

SC	Internal pressure		External pressure		d_1	d_2
	d_7		d_8			
	nom.	tol.	nom.	tol.	nom.	nom.
217	36,80	H9	30,05	h9	29,74	3,53
218	38,40	H9	31,65	h9	31,34	3,53
219	39,98	H9	33,25	h9	32,92	3,53
220	41,58	H9	34,87	h9	34,52	3,53
221	43,18	H9	36,45	h9	36,09	3,53
222	44,75	H9	38,07	h9	37,69	3,53
223	47,93	H9	41,28	h9	40,87	3,53
224	51,10	H9	44,48	h9	44,04	3,53
225	54,28	H9	47,70	h9	47,22	3,53
226	57,45	H9	50,90	h9	50,39	3,53
227	60,63	H9	54,10	h9	53,57	3,53
228	63,80	H9	57,30	h9	56,74	3,53
229	66,98	H9	60,53	h9	59,92	3,53
230	70,15	H9	63,73	h9	63,09	3,53
231	73,33	H9	66,93	h9	66,27	3,53
232	76,50	H9	70,13	h9	69,44	3,53
233	79,68	H9	73,36	h9	72,62	3,53
234	82,85	H9	76,56	h9	75,79	3,53
235	86,03	H9	79,76	h9	78,97	3,53
236	89,20	H9	82,96	h9	82,14	3,53
237	92,38	H9	86,18	h9	85,32	3,53
238	95,55	H9	89,38	h9	88,49	3,53
239	98,73	H9	92,58	h9	91,67	3,53
240	101,90	H9	95,73	h9	94,84	3,53
241	105,08	H9	99,01	h9	98,02	3,53
242	108,25	H9	102,20	h9	101,19	3,53
243	111,43	H9	105,41	h9	104,37	3,53
244	114,60	H9	108,61	h9	107,54	3,53
245	117,78	H9	111,83	h9	110,72	3,53
246	120,95	H9	115,03	h9	113,89	3,53
247	124,13	H9	118,23	h9	117,07	3,53
248	127,30	H9	121,43	h9	120,24	3,53
249	130,48	H9	124,66	h9	123,42	3,53
250	133,65	H9	127,86	h9	126,59	3,53
251	136,83	H9	131,06	h9	129,77	3,53
252	140,00	H9	134,26	h9	132,94	3,53
253	143,18	H9	137,49	h9	136,12	3,53

SC	Internal pressure		External pressure		d_1	d_2
	d_7		d_8			
	nom.	tol.	nom.	tol.	nom.	nom.
254	146,35	H9	140,69	h9	139,29	3,53
255	149,53	H9	143,89	h9	142,47	3,53
256	152,70	H9	147,09	h9	145,64	3,53
257	155,88	H9	150,31	h9	148,82	3,53
258	159,05	H9	153,51	h9	151,99	3,53
259	165,40	H9	159,86	h9	158,34	3,53
260	171,75	H9	166,21	h9	164,69	3,53
261	178,10	H9	172,56	h9	171,04	3,53
262	184,45	H9	178,91	h9	177,39	3,53
263	190,80	H9	185,26	h9	183,74	3,53
264	197,15	H9	191,61	h9	190,09	3,53
265	203,50	H9	197,96	h9	196,44	3,53
266	209,85	H9	204,31	h9	202,79	3,53
267	216,20	H9	210,66	h9	209,14	3,53
268	222,55	H9	217,01	h9	215,49	3,53
269	228,90	H9	223,36	h9	221,84	3,53
270	235,25	H9	229,71	h9	228,19	3,53
271	241,60	H9	233,06	h9	234,54	3,53
272	247,95	H9	241,42	h9	240,89	3,53
273	254,30	H9	248,76	h9	247,24	3,53
274	260,65	H9	255,11	h9	253,59	3,53
275	273,35	H9	267,81	h9	266,29	3,53
276	286,05	H9	280,51	h9	278,99	3,53
277	298,75	H9	293,21	h9	291,69	3,53
278	311,45	H9	305,91	h9	304,39	3,53
279	336,85	H9	331,31	h9	329,79	3,53
280	362,25	H9	356,71	h9	355,19	3,53
281	387,65	H9	382,11	h9	380,59	3,53
282	413,05	H9	406,78	h9	405,26	3,53
283	438,45	H9	432,18	h9	430,68	3,53
284	463,85	H9	457,58	h9	456,06	3,53
309	21,13	H9	10,57	h9	10,46	5,33
310	22,73	H9	12,19	h9	12,07	5,33
311	24,31	H9	13,77	h9	13,64	5,33
312	25,91	H9	15,39	h9	15,24	5,33
313	27,48	H9	16,99	h9	16,81	5,33
314	29,08	H9	18,59	h9	18,42	5,33

SC	Internal pressure		External pressure		d_1	d_2
	d_7		d_8			
	nom.	tol.	nom.	tol.	nom.	nom.
315	30,66	H9	20,19	h9	19,99	5,33
316	32,26	H9	21,82	h9	21,59	5,33
317	33,83	H9	23,39	h9	23,16	5,33
318	35,43	H9	25,02	h9	24,77	5,33
319	37,01	H9	26,59	h9	26,34	5,33
320	38,61	H9	28,22	h9	27,94	5,33
321	40,18	H9	29,82	h9	29,51	5,33
322	41,78	H9	31,42	h9	31,12	5,33
323	43,36	H9	33,02	h9	32,69	5,33
324	44,96	H9	34,65	h9	34,29	5,33
325	48,13	H9	37,85	h9	37,47	5,33
326	51,31	H9	41,05	h9	40,64	5,33
327	54,48	H9	44,25	h9	43,82	5,33
328	57,66	H9	47,47	h9	46,99	5,33
329	60,83	H9	50,67	h9	50,17	5,33
330	64,01	H9	53,87	h9	53,34	5,33
331	67,18	H9	57,07	h9	56,52	5,33
332	70,36	H9	60,30	h9	59,69	5,33
333	73,53	H9	63,50	h9	62,87	5,33
334	76,71	H9	66,70	h9	66,04	5,33
335	79,88	H9	69,90	h9	69,22	5,33
336	83,06	H9	73,13	h9	72,39	5,33
337	86,23	H9	76,33	h9	75,57	5,33
338	89,41	H9	79,53	h9	78,74	5,33
339	92,58	H9	82,73	h9	81,92	5,33
340	95,76	H9	85,95	h9	85,09	5,33
341	98,93	H9	89,15	h9	88,27	5,33
342	102,10	H9	92,35	h9	91,44	5,33
343	105,28	H9	95,55	h9	94,62	5,33
344	108,45	H9	98,78	h9	97,79	5,33
345	111,63	H9	101,98	h9	100,97	5,33
346	114,80	H9	105,18	h9	104,14	5,33
347	117,98	H9	108,38	h9	107,32	5,33
348	119,38	H9	111,60	h9	110,49	5,33
349	124,33	H9	114,80	h9	113,67	5,33
350	127,50	H9	118,00	h9	116,84	5,33
351	130,68	H9	121,20	h9	120,02	5,33

SC	Internal pressure		External pressure		d_1	d_2
	d_7		d_8			
	nom.	tol.	nom.	tol.	nom.	nom.
352	133,85	H9	124,43	h9	123,19	5,33
353	137,03	H9	127,63	h9	126,37	5,33
354	140,81	H9	130,83	h9	129,54	5,33
355	143,38	H9	134,03	h9	132,72	5,33
356	146,56	H9	137,26	h9	135,89	5,33
357	149,73	H9	140,46	h9	139,07	5,33
358	152,90	H9	143,64	h9	142,24	5,33
359	156,08	H9	146,86	h9	145,42	5,33
360	159,25	H9	150,08	h9	148,59	5,33
361	162,43	H9	153,28	h9	151,77	5,33
362	168,78	H9	159,63	h9	158,12	5,33
363	175,13	H9	165,98	h9	164,47	5,33
364	181,48	H9	172,33	h9	170,82	5,33
365	187,83	H9	178,68	h9	177,17	5,33
366	194,18	H9	185,03	h9	183,52	5,33
367	200,53	H9	191,38	h9	189,87	5,33
368	206,88	H9	197,73	h9	196,22	5,33
369	213,23	H9	204,08	h9	202,57	5,33
370	219,58	H9	210,43	h9	208,92	5,33
371	225,93	H9	216,78	h9	215,27	5,33
372	232,28	H9	223,13	h9	221,62	5,33
373	238,63	H9	229,48	h9	227,97	5,33
374	244,98	H9	235,83	h9	234,32	5,33
375	251,33	H9	242,18	h9	240,67	5,33
376	257,68	H9	248,53	h9	247,02	5,33
377	264,03	H9	254,88	h9	253,37	5,33
378	276,73	H9	267,58	h9	266,07	5,33
379	289,43	H9	280,28	h9	278,77	5,33
380	302,13	H9	292,98	h9	291,47	5,33
381	314,83	H9	305,68	h9	304,17	5,33
382	340,23	H9	331,08	h9	329,57	5,33
383	365,63	H9	356,48	h9	354,97	5,33
384	391,03	H9	381,88	h9	380,37	5,33
385	415,92	H9	406,78	h9	405,26	5,33
386	441,32	H9	432,18	h9	430,66	5,33
387	466,72	H9	457,58	h9	456,06	5,33
388	492,07	H9	482,90	h9	481,38	5,33

SC	Internal pressure		External pressure		d_1	d_2
	d_7		d_8			
	nom.	tol.	nom.	tol.	nom.	nom.
389	517,47	H9	508,30	h9	506,78	5,33
390	542,87	H9	533,70	h9	532,18	5,33
391	568,27	H9	559,10	h9	557,58	5,33
392	593,34	H9	584,20	h9	582,68	5,33
393	618,74	H9	609,60	h9	608,08	5,33
394	644,14	H9	635,00	h9	633,48	5,33
395	669,54	H9	660,40	h9	658,88	5,33
425	127,63	H9	114,80	h9	113,67	6,99
426	130,81	H9	118,00	h9	116,84	6,99
427	133,98	H9	121,20	h9	120,02	6,99
428	137,16	H9	124,43	h9	123,19	6,99
429	140,33	H9	127,63	h9	126,37	6,99
430	143,51	H9	130,83	h9	129,54	6,99
431	146,68	H9	134,03	h9	132,72	6,99
432	149,86	H9	137,26	h9	135,89	6,99
433	153,03	H9	140,46	h9	139,07	6,99
434	156,21	H9	143,66	h9	142,24	6,99
435	159,38	H9	146,86	h9	145,42	6,99
436	162,56	H9	150,08	h9	148,59	6,99
437	165,73	H9	153,28	h9	151,77	6,99
438	172,06	H9	159,63	h9	158,12	6,99
439	178,43	H9	165,98	h9	164,47	6,99
440	184,78	H9	172,33	h9	170,82	6,99
441	191,13	H9	178,68	h9	177,17	6,99
442	197,48	H9	185,03	h9	183,52	6,99
443	203,83	H9	191,38	h9	189,87	6,99
444	210,18	H9	197,73	h9	196,22	6,99
445	216,53	H9	204,08	h9	202,57	6,99
446	229,23	H9	216,78	h9	215,27	6,99

SC	Internal pressure		External pressure		d_1	d_2
	d_7		d_8			
	nom.	tol.	nom.	tol.	nom.	nom.
447	241,93	H9	229,48	h9	227,97	6,99
448	254,63	H9	242,18	h9	240,67	6,99
449	267,33	H9	254,88	h9	253,37	6,99
450	280,03	H9	267,58	h9	266,07	6,99
451	292,73	H9	280,28	h9	278,77	6,99
452	305,43	H9	292,98	h9	291,47	6,99
453	318,13	H9	305,68	h9	304,17	6,99
454	330,83	H9	318,38	h9	316,87	6,99
455	343,53	H9	331,08	h9	329,57	6,99
456	356,23	H9	343,78	h9	342,27	6,99
457	368,93	H9	356,48	h9	354,97	6,99
458	381,63	H9	369,18	h9	367,67	6,99
459	394,33	H9	381,88	h9	380,37	6,99
460	407,03	H9	394,58	h9	393,07	6,99
461	419,22	H9	406,78	h9	405,26	6,99
462	431,92	H9	419,48	h9	417,96	6,99
463	444,62	H9	432,18	h9	430,66	6,99
464	457,32	H9	444,88	h9	443,36	6,99
465	470,02	H9	457,58	h9	456,06	6,99
466	482,72	H9	470,28	h9	468,76	6,99
467	495,42	H9	482,98	h9	481,46	6,99
468	508,12	H9	495,68	h9	494,16	6,99
469	520,82	H9	508,38	h9	506,86	6,99
470	546,22	H9	533,78	h9	532,26	6,99
471	571,62	H9	559,18	h9	557,66	6,99
472	596,64	H9	584,20	h9	582,68	6,99
473	622,05	H9	608,20	h9	608,08	6,99
474	647,44	H9	635,00	h9	633,48	6,99
475	672,84	H9	660,40	h9	658,88	6,99

.....

Annex A (informative)

Correlation of ISO 3601-1 aerospace O-ring size identification code with EN 3748 O-ring housing codes

ISO 3601-1 O-rings for aerospace applications use housings identified in EN 3748. These housings have size codes that relate directly to the size codes for the aerospace series O-rings of ISO 3601-1. To identify the proper O-ring and its respective housing, the correlation examples shown in Table A.1 should be used.

**Table A.1 — Correlation between size code for ISO 3601-1 series A O-rings
and the appropriate housing size codes of EN 3748**

ISO 3601-1 aerospace series O-ring size code	EN 3748 housing size code
A0040	A0040
B0500	B0500
C0800	C0800
D0900	D0900
E2000	E2000

Annex B (informative)

How to determine the proper O-ring size for custom housings used for radial and axial applications

B.1 General

B.1.1 Housing dimensions for the majority of applications are listed in this part of ISO 3601; however, there exists the possibility that custom hardware can be required for specialized applications. These special applications normally start off with a custom bore or rod size for radial applications and a nominal housing dimension for axial applications. It is then necessary to complete the hardware dimensions and identify an O-ring that can function in the application. This annex lists the steps that should be performed to finalize the hardware dimensions and identify the proper O-ring. The calculations are based upon two premises required for good sealing: 2 % stretch for radial applications and the proper O-ring compression for both the radial and axial applications as detailed in Figure 8.

B.1.2 Housing fill or occupancy of the O-ring should also be considered for radial applications (see 6.3). For reference purposes, the approximate maximum housing fill, F_{\max} , expressed in percent, can be calculated by dividing the maximum cross-sectional area of the installed O-ring, A_{cs1} , by the minimal cross-sectional area of the housing, A_{cs2} , in accordance with Equations (B.1) to (B.3):

$$A_{cs1, \max} = \pi \times \left(\frac{d_{2, \max}^*}{2} \right)^2 \quad (\text{B.1})$$

$$A_{cs2, \min} = t_{\min} \times b_{x, \min} \quad (\text{B.2})$$

$$F_{\max} = \left(A_{cs1, \max} / A_{cs2, \min} \right) \times 100 \quad (\text{B.3})$$

B.2 Piston applications

B.2.1 For a piston application, the bore of the cylinder is established and H8 tolerance is applied to the bore dimension and f7 tolerance is applied to the piston.

For example, if a bore of 123 mm is required, d_4 is then fixed at 123 mm to a maximum of 123,06 mm. The piston diameter, d_9 , is then fixed at 122,96 mm to a minimum of 122,92 mm.

B.2.2 Knowing the value of d_4 , the nominal cross-section of the appropriate O-ring is determined from Table B.1.

Table B.1 — Recommended O-ring cross-sections for piston applications

Dimensions in millimetres

Bore diameter d_4	Nominal O-ring cross-section d_2
4 to 12	1,78
> 12 to 24	2,62
> 24 to 46	3,53
> 46 to 124	5,33
> 124 to 500	6,99

The appropriate nominal O-ring cross-section, d_2 , for this application is 5,33 mm.

B.2.3 Next, the application is identified as this fixes the appropriate compression for the O-ring. If this application is a static piston application, the maximum O-ring compression is then determined from Figure 8 to be 28 %.

B.2.4 Once the O-ring cross-section and maximum compression are identified, the approximate housing depth, t_x , can be calculated in accordance with Equation (B.4):

$$\begin{aligned}
 t_x &= d_{2, \text{nom}} - \left[(C_{\text{nom}} \times d_{2, \text{nom}}) / 100 \right] & \text{(B.4)} \\
 &= 5,33 - \left[(20 \times 5,33) / 100 \right] \\
 &= 4,27 \text{ mm}
 \end{aligned}$$

where C_{nom} is the nominal squeeze, expressed in percent.

B.2.5 The approximate housing diameter, d_3 , can be calculated using the approximate housing depth, t_x , calculated in B.2.4, in accordance with Equation (B.5):

$$\begin{aligned}
 d_3 &= d_4 - 2(t_x) & \text{(B.5)} \\
 &= 123 - 2(4,27) \\
 &= 114,46 \text{ mm}
 \end{aligned}$$

B.2.6 The maximum inside diameter, $d_{1, \text{max}}$, of the O-ring can now be calculated using the recommended minimum stretch of 2 % in accordance with Equation (B.6):

$$\begin{aligned}
 d_{1, \text{max}} &= 0,98 \times d_3 & \text{(B.6)} \\
 &= 0,98 \times 114,46 \\
 &= 112,17 \text{ mm}
 \end{aligned}$$

The nominal inside diameter, d_1 , of the O-ring, using the tolerances listed in ISO 3601-1:2008, Table A.2, is then 111,41 mm.

B.2.7 As detailed in this part of ISO 3601, the percentage of the cross-section, R , resulting from a 2 % diametrical stretch is 1,73 % and the effective O-ring cross-section, d_2^* , can be calculated in accordance with Equation (B.7):

$$\begin{aligned}
 d_2^* &= d_2 - [(R/100) \times d_2] && \text{(B.7)} \\
 &= 5,33 - 0,092 \\
 &= 5,24 \text{ mm}
 \end{aligned}$$

B.2.8 For this application, using the tolerance listed in ISO 3601-1:2008, Table A.2, the O-ring size is fixed as 111,41 mm × 5,33 mm and the housing diameter, as 114,66 mm.

The user can either use the custom O-ring or consult ISO 3601-1 for the closest standard size O-ring that is available, but should verify the suitability. The eccentricity and tolerances of the hardware and O-ring should be considered.

The verification of suitability of this O-ring shows that, based upon tolerances, the squeeze can range from 15 % to 20 % when cross-section reduction is taken into account. The elongation can range from 2 % to 3 % and the housing fill can range from 64 % to 74 %. All of these values are consistent with the sealing philosophy of this document.

B.3 Rod applications

B.3.1 For a rod application, the diameter of the rod is normally identified as $\varnothing d_5$ f7, and knowing that the tolerance for the bore diameter, d_{10} , is H8 means that the rod and bore dimensions are the established starting points for completing the hardware dimensions. Also, knowing the d_5 dimension allows the selection of the proper nominal O-ring cross-section, d_2 , from Table B.2.

Table B.2 — Recommended O-ring cross-sections for rod applications

Dimensions in millimetres

Rod diameter d_5	Nominal O-ring cross-section d_2
2 to 8	1,78
> 8 to 18	2,62
> 18 to 38	3,53
> 38 to 112	5,33
> 112 to 400	6,99

B.3.2 Using as an example a rod with $\varnothing 34$ f7, the starting dimensions are established as

- $d_5 = 33,98/33,95$ mm,
- $d_{10} = 34/34,04$ mm,
- $d_2 = 3,53$ mm.

B.3.3 The maximum compression of the O-ring cross-section is then identified from Figure 8 of this part of ISO 3601. For this example, the application is a dynamic one for a hydraulic system. The maximum compression should be 22 %.

B.3.4 Once the O-ring cross-section and maximum compression are identified, the approximate housing depth, t_x , can be calculated in accordance with Equation (B.8):

$$\begin{aligned} t_x &= d_{2, \text{nom}} - \left[\left(C_{\text{max}} \times d_{2, \text{nom}} \right) / 100 \right] & \text{(B.8)} \\ &= 3,53 - \left[\left(22 \times 3,53 \right) / 100 \right] \\ &= 2,75 \text{ mm (min.)} \end{aligned}$$

B.3.5 The housing diameter, d_6 , can be calculated using the approximate housing depth, t_x , calculated in B.3.4, in accordance with Equation (B.9):

$$\begin{aligned} d_6 &= d_{5, \text{max}} + 2(t_x) & \text{(B.9)} \\ &= 33,98 + 2(2,75) \\ &= 39,48 \text{ mm} \end{aligned}$$

B.3.6 The maximum inside diameter, d_1 , of the O-ring is now calculated using the recommended minimum stretch of 2 %, in accordance with Equation (B.10):

$$\begin{aligned} d_1 &= 0,98 \times d_{5, \text{max}} & \text{(B.10)} \\ &= 0,98 \times 33,98 \\ &= 33,30 \text{ mm (max.)} \end{aligned}$$

B.3.7 As detailed in this part of ISO 3601, the percentage of cross-section reduction, R , resulting from 2 % diametral stretch is 1,73 % and the effective O-ring cross-section, d_2^* , can be calculated in accordance with Equation (B.11):

$$\begin{aligned} d_2^* &= d_{2, \text{nom}} - \left[\left(R / 100 \right) \times d_{2, \text{nom}} \right] & \text{(B.11)} \\ &= 3,53 - 0,06 \\ &= 3,47 \text{ mm} \end{aligned}$$

B.3.8 When the proper tolerance from ISO 3601-1:2008, Table A.2, is applied to the d_1 dimension, for this application, the O-ring nominal size is fixed as 33 mm \times 3,53 mm and the housing diameter, as 39,48 mm.

The user can either use the custom O-ring or consult ISO 3601-1 for the closest standard size O-ring that is available, but should verify the suitability. The eccentricity and tolerances of the hardware and O-ring should be considered.

The verification of suitability of this O-ring shows that, based upon tolerances, the squeeze can range from 16 % to 22 % when cross-section reduction is taken into account. The elongation can range from 2 % to 4 % and the housing fill can range from 59 % to 73 %. The compression of the O-ring in the housing can range from 0,05 % to 2,66 %. All of these values are consistent with the sealing philosophy of this document.

B.4 Axial seal applications

B.4.1 General

For axial sealing applications, the nominal housing diameter and tolerance grade, H9, the pressure direction and the media being sealed are known.

B.4.2 Internal pressure applications

B.4.2.1 In these applications, the outside diameter of the O-ring should be line-on-line with the outer wall of the housing when the O-ring inside diameter is at nominal size and the wall of the housing is at the maximum size. The O-ring cross-section should be the largest cross-section that can possibly be chosen based on hardware constraints. The larger the cross-section, the less prone the O-ring is to compression set, and O-rings with larger cross-sections are less prone to leakage due to contamination and scratches on the sealing surfaces.

B.4.2.2 The O-ring size needed for a 100 mm H9 housing used in an internal pressure application can be determined by the following process.

- a) If a value of 100 mm is chosen as the nominal housing diameter, d_7 , applying the H9 tolerance grade means that the maximum value for d_7 is 100,04 mm.
- b) The hardware is substantial enough that a nominal O-ring cross-section of 5,33 mm can be chosen.
- c) The application is for a hydraulic system.
- d) From Table 6, the housing width, b_4 , is determined to be 7,6 mm to 7,8 mm and the housing height, h , is determined to be 4,2 mm to 4,3 mm. The values for f and surface roughness are also determined from Table 6.
- e) The O-ring inside diameter, d_1 , is then determined in accordance with Equation (B.12):

$$\begin{aligned}
 d_{1, \text{nom}} &= d_{7, \text{max}} - 2d_{2, \text{nom}} && \text{(B.12)} \\
 &= 100,04 - 2(5,33) \\
 &= 92,98 \text{ mm}
 \end{aligned}$$

The tolerances for d_1 in ISO 3601-1:2008, Table A.2, should be applied.

B.4.3 External pressure applications

B.4.3.1 In these applications, the inside diameter of the O-ring should be line-on-line with the inner wall of the housing when the O-ring inside diameter is at nominal size and the wall of the housing inner wall is at the minimum size. The O-ring cross-section should be the largest cross-section that can possibly be chosen based on hardware constraints. The larger the cross-section, the less prone the O-ring is to compression set, and O-rings with larger cross-sections are less prone to leakage due to contamination and scratches on the sealing surfaces.

B.4.3.2 The O-ring size needed for a 100 mm H9 housing used in an external pressure application can be determined by the following process.

- a) If a value of 100 mm is chosen as the nominal housing diameter, d_8 , applying the H9 tolerance grade means that the minimum value for d_7 is 99,97 mm.
- b) The hardware is substantial enough that a 3,53 mm O-ring cross-section can be chosen.

- c) The application is for a hydraulic system.
- d) From Table 6, the housing width, b_4 , is determined to be 5,3 mm to 5,5 mm, and the housing height, h , is determined to be 2,7 mm to 2,8 mm. The values for f and surface roughness are also determined from the table.
- e) The O-ring inside diameter, d_1 , is then determined in accordance with Equation (B.13):

$$\begin{aligned}d_{1, \text{nom}} &= d_{8, \text{min}} && \text{(B.13)} \\ &= 99,97 \text{ mm}\end{aligned}$$

The tolerances for d_1 in ISO 3601-1:2008, Table A.2, should be applied.

Bibliography

- [1] ISO 286-1, *ISO system of limits and fits — Part 1: Bases of tolerances, deviations and fits*
- [2] ISO 286-2, *ISO system of limits and fits — Part 2: Tables of standard tolerance grades and limit deviations for holes and shafts*
- [3] ISO 1101, *Geometrical Product Specifications (GPS) — Geometrical tolerancing — Tolerances of form, orientation, location and run-out*
- [4] ISO 1302, *Geometrical Product Specification (GPS) — Indication of surface texture in technical product documentation*
- [5] ISO 3601-3, *Fluid power systems — O-rings — Part 3: Quality acceptance criteria*
- [6] ISO 4288, *Geometrical Product Specifications (GPS) — Surface texture: Profile method — Rules and procedures for the assessment of surface texture*
- [7] ISO 8785, *Geometrical Product Specification (GPS) — Surface imperfections — Terms, definitions and parameters*
- [8] ISO 13715, *Technical drawings — Edges of undefined shape — Vocabulary and indications*
- [9] EN 3748, *Aerospace series — O-ring grooves — Dimensions*
- [10] SAE MAP 3340, *O-ring groove design for packing preformed, elastomeric O-ring seals, static, radial squeeze, metric*, Society of Automotive Engineers, Warrendale, PA
- [11] ZIELINSKI, Ronald E., *Seals and Seal Compatibility*, in *Handbook of Hydraulic Fluid Technology*, Marcel Dekker, New York, 2000
- [12] *The Language of Rubber*, E. I. du Pont de Nemours and Co. (Inc.), Wilmington, DE, 1957
- [13] POTOSKY, T., *Putting a shine on seal performance*, in *Machine Design*, Penton Publishing Inc., Cleveland, OH, 1996

ICS 23.100.60; 83.140.50

Price based on 44 pages