

INTERNATIONAL STANDARD

ISO 3584

Second edition
2001-11-01

Road vehicles — Drawbar couplings — Interchangeability

Véhicules routiers — Dispositifs d'attelage — Interchangeabilité



Reference number
ISO 3584:2001(E)

© ISO 2001

PDF disclaimer

This PDF file may contain embedded typefaces. In accordance with Adobe's licensing policy, this file may be printed or viewed but shall not be edited unless the typefaces which are embedded are licensed to and installed on the computer performing the editing. In downloading this file, parties accept therein the responsibility of not infringing Adobe's licensing policy. The ISO Central Secretariat accepts no liability in this area.

Adobe is a trademark of Adobe Systems Incorporated.

Details of the software products used to create this PDF file can be found in the General Info relative to the file; the PDF-creation parameters were optimized for printing. Every care has been taken to ensure that the file is suitable for use by ISO member bodies. In the unlikely event that a problem relating to it is found, please inform the Central Secretariat at the address given below.

© ISO 2001

All rights reserved. Unless otherwise specified, no part of this publication may be reproduced or utilized in any form or by any means, electronic or mechanical, including photocopying and microfilm, without permission in writing from either ISO at the address below or ISO's member body in the country of the requester.

ISO copyright office
Case postale 56 • CH-1211 Geneva 20
Tel. + 41 22 749 01 11
Fax + 41 22 749 09 47
E-mail copyright@iso.ch
Web www.iso.ch

Printed in Switzerland

Foreword

ISO (the International Organization for Standardization) is a worldwide federation of national standards bodies (ISO member bodies). The work of preparing International Standards is normally carried out through ISO technical committees. Each member body interested in a subject for which a technical committee has been established has the right to be represented on that committee. International organizations, governmental and non-governmental, in liaison with ISO, also take part in the work. ISO collaborates closely with the International Electrotechnical Commission (IEC) on all matters of electrotechnical standardization.

International Standards are drafted in accordance with the rules given in the ISO/IEC Directives, Part 3.

The main task of technical committees is to prepare International Standards. Draft International Standards adopted by the technical committees are circulated to the member bodies for voting. Publication as an International Standard requires approval by at least 75 % of the member bodies casting a vote.

Attention is drawn to the possibility that some of the elements of this International Standard may be the subject of patent rights. ISO shall not be held responsible for identifying any or all such patent rights.

ISO 3584 was prepared by Technical Committee ISO/TC 22, *Road vehicles*, Subcommittee SC 15, *Interchangeability of components of commercial vehicles and buses*.

This second edition cancels and replaces the first edition (ISO 3584:1975), which has been technically revised.

Road vehicles — Drawbar couplings — Interchangeability

1 Scope

This International Standard specifies the characteristics necessary for the mounting and interchangeability of drawbar couplings on the frame (cross member, drawbeam or mounting bracket) of towing vehicles for trailers.

This International Standard is applicable to drawbar couplings intended for connection to trailers equipped with a drawbar eye on the drawbar of the trailer.

Characteristics not specified are left to the discretion of the component manufacturer.

2 Normative references

The following normative documents contain provisions which, through reference in this text, constitute provisions of this International Standard. For dated references, subsequent amendments to, or revisions of, any of these publications do not apply. However, parties to agreements based on this International Standard are encouraged to investigate the possibility of applying the most recent editions of the normative documents indicated below. For undated references, the latest edition of the normative document referred to applies. Members of ISO and IEC maintain registers of currently valid International Standards.

ISO 1102, *Commercial road vehicles — 50 mm drawbar eye — Interchangeability*

ISO 8718, *Commercial road vehicles — Drawbar couplings and eyes for hinged drawbars — Strength tests*

ISO 8755, *Commercial road vehicles — 40 mm drawbar eye — Interchangeability*

ISO 12357, *Commercial road vehicles — Drawbar couplings and eyes for rigid drawbars — Strength tests*

3 Designation

3.1 Reference may be made to this International Standard both for drawbar coupling mounting dimensions on the frame and for the separate drawbar coupling.

3.2 Frames in conformance with this International Standard shall be identified by the following information, in the order given:

- a) reference to this International Standard;
- b) number of category according to Table 1.

EXAMPLE Frames with mounting dimensions according to category 3:

Crossmember (or drawbeam or mounting bracket) ISO 3584 - Category 3

3.3 Drawbar couplings meeting the requirements of this International Standard shall be identified by the following information, in the order given:

- a) reference to this International Standard;
- b) code C 40 for 40 mm drawbar couplings and C 50 for 50 mm drawbar couplings, as applicable;
- c) number of category according to Table 1 or number of class according to Table 4.

EXAMPLE 1 40 mm drawbar coupling according to category 3:

Drawbar coupling ISO 3584 C 40 - Category 3

EXAMPLE 2 50 mm drawbar coupling according to class 3:

Drawbar coupling ISO 3584 C 50 - Class 3

EXAMPLE 3 Drawbar coupling according to category 4:

Drawbar coupling ISO 3584 - Category 4

4 Mounting categories

4.1 Categories of drilling pattern

The dimensions for the categories of drilling pattern (see Figure 1) shall be as given in Table 1.

Table 1 — Categories of drilling pattern

Dimensions in millimetres

Dimension	Category				
	1	2	3	4	5 to 7
E_1	83	83	120	140	160
E_2	56	56	55	80	100
D_1	—	55	75	85	95
D_2	10,5	10,5	15	17	21

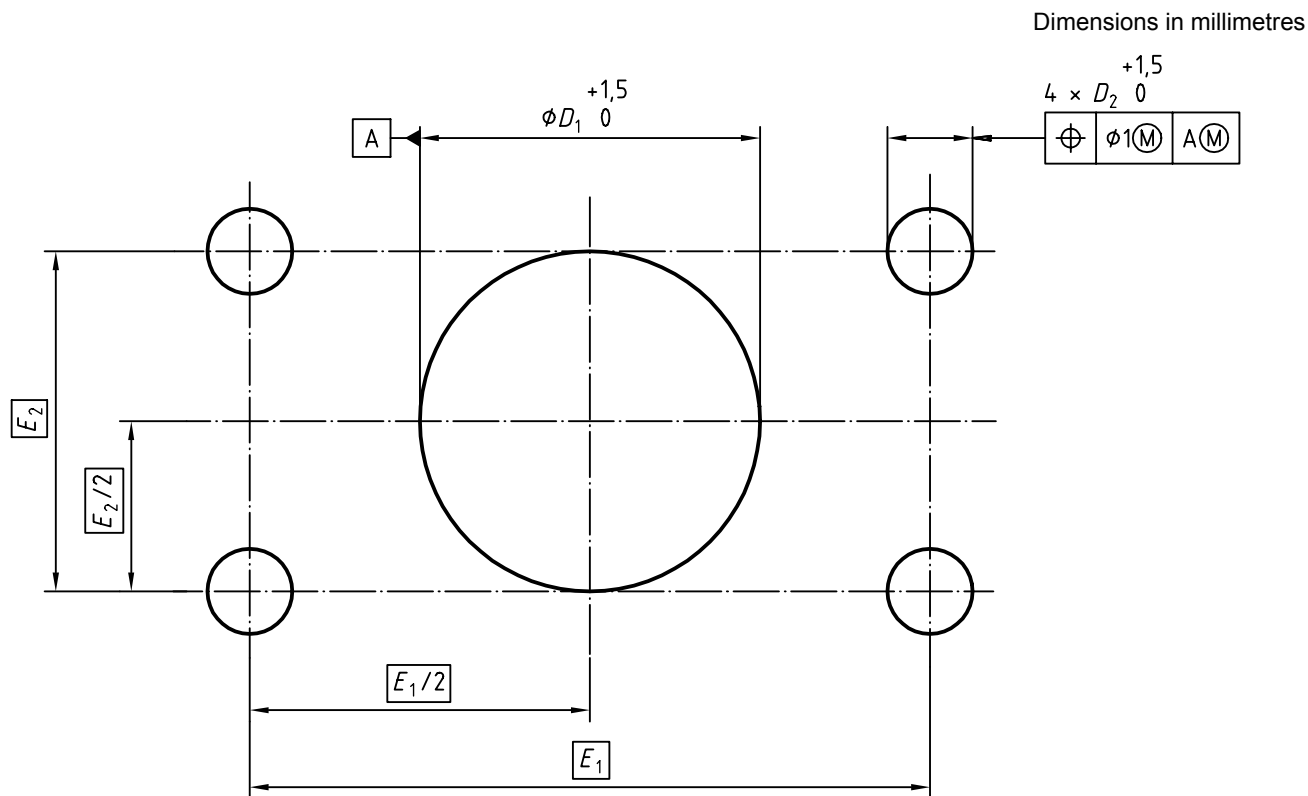

Figure 1 — Drilling pattern

4.2 Dimensional requirements on frame for mounting drawbar coupling

Dimensions on the frame required for mounting of the drawbar coupling (see Figure 2), such as the minimum flat surface defined by dimensions F and G , shall be as given in Table 2. Tolerances on drilling pattern dimensions shall be as shown in Figure 1.

Table 2 — Dimensional requirements for frames

Dimensions in millimetres

Dimension	Category				
	1	2	3	4	5 to 7
F max.	120	120	165	190	210
G min.	95	95	100	130	150
T max.	—	15	20	35	35
L_1 min.	—	200	300	400	400

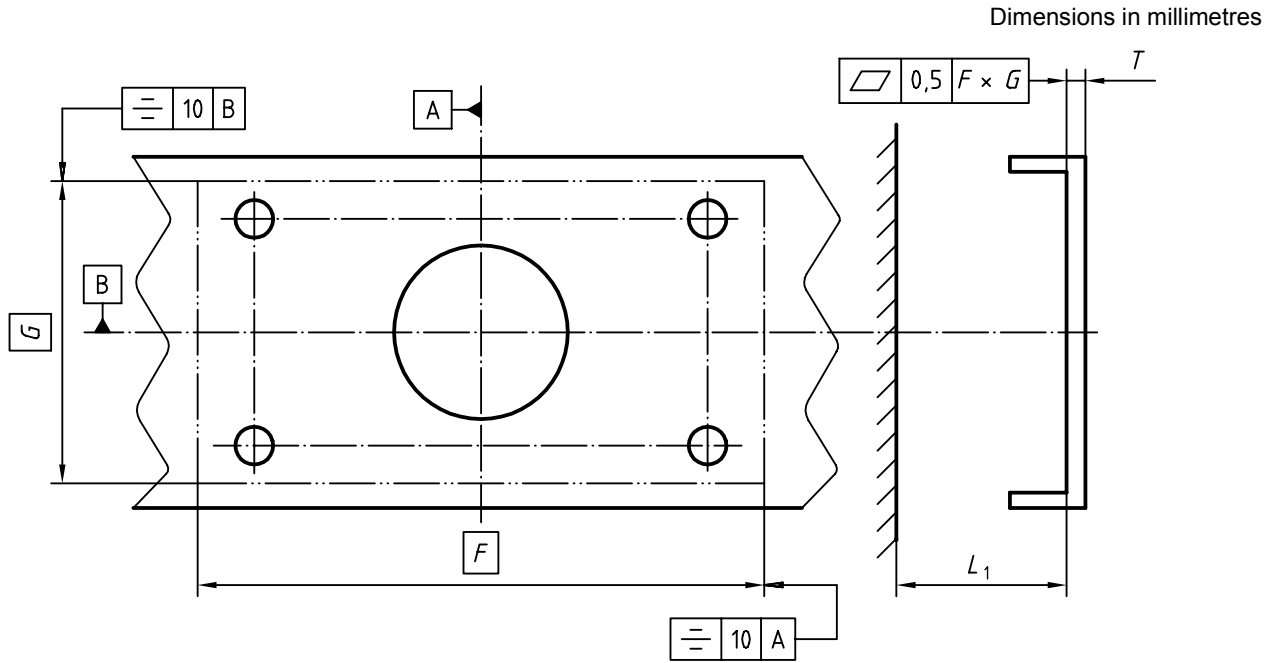

Figure 2 — Dimensional characteristics of frame

5 Drawbar Couplings

5.1 General

The requirements of 5.2 to 5.4 are applicable to all drawbar couplings. Additional requirements applicable to C 40, C 50 and classified drawbar couplings of both dimensions are given in 5.5.

5.2 Load requirements

The drawbar coupling shall satisfy the tests specified in ISO 8718 or ISO 12357 or both.

5.3 Dimensional requirements

The maximum outer dimensions of all components of the drawbar coupling shall be within the envelope box defined in Table 3 (see Figure 3).

In order to permit safer operation of the drawbar coupling, there shall be adequate free space around actuating devices. Dimensions needed to ensure operating clearance for actuating devices are also shown in Figure 3.

Table 3 — Dimensions of drawbar coupling envelope box

Dimensions in millimetres

Dimension	Category				
	1	2	3	4	5 to 7
<i>M</i>	95	95	100	130	150
<i>N</i>	120	120	165	190	210
<i>P</i>	—	180	280	330	330
<i>Q</i>	150	300	330	330	330
<i>R</i>	95	130	145	145	145
<i>S</i>	250	250	250	250	250
<i>J</i>	265	365	465	465	465
$K \begin{smallmatrix} 0 \\ -65 \end{smallmatrix}$	165	215	265	265	265

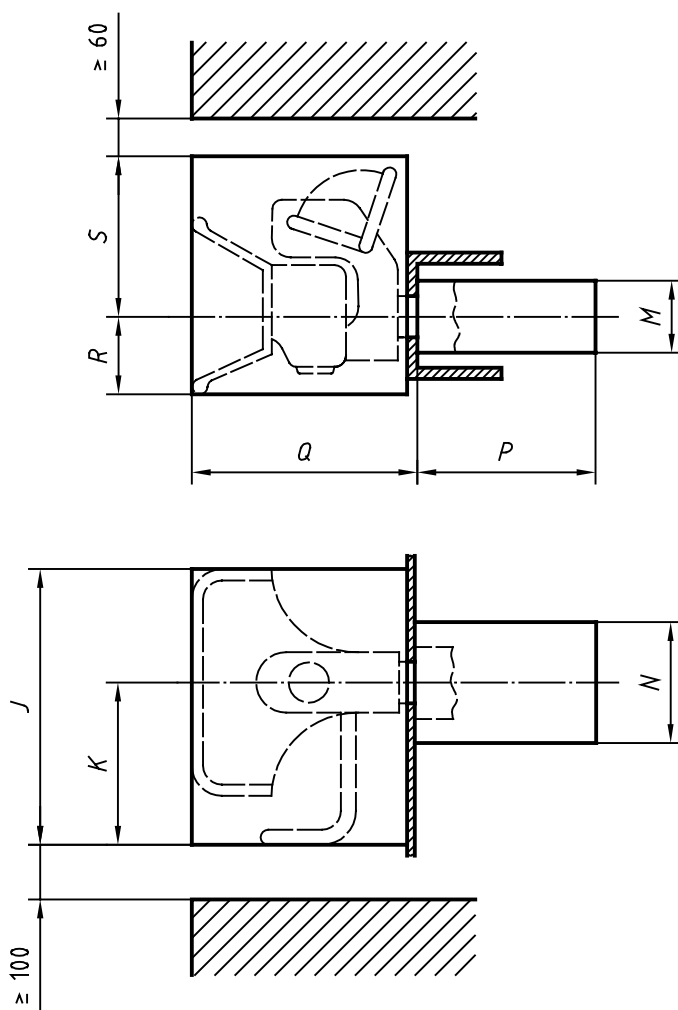

Figure 3 — Drawbar coupling envelope box and operating clearance for actuating devices

5.4 Articulation angles

The drawbar coupling shall be designed so as to permit the drawbar eye, when coupled but not fitted to a vehicle, to reach the following non-simultaneous degrees of articulation:

- $\pm 90^\circ$ horizontally about the vertical axis from the longitudinal axis of the vehicle (see Figure 4);
- $\pm 20^\circ$ vertically about the transverse axis from the horizontal plane of the vehicle (see Figure 5);
- $\pm 25^\circ$ axial rotation about the longitudinal axis from the horizontal plane of the vehicle (see Figure 6).

NOTE Dimensions for ensuring operating clearance between towing vehicles and trailers are given in ISO 11406^[1] and ISO 11407^[2].

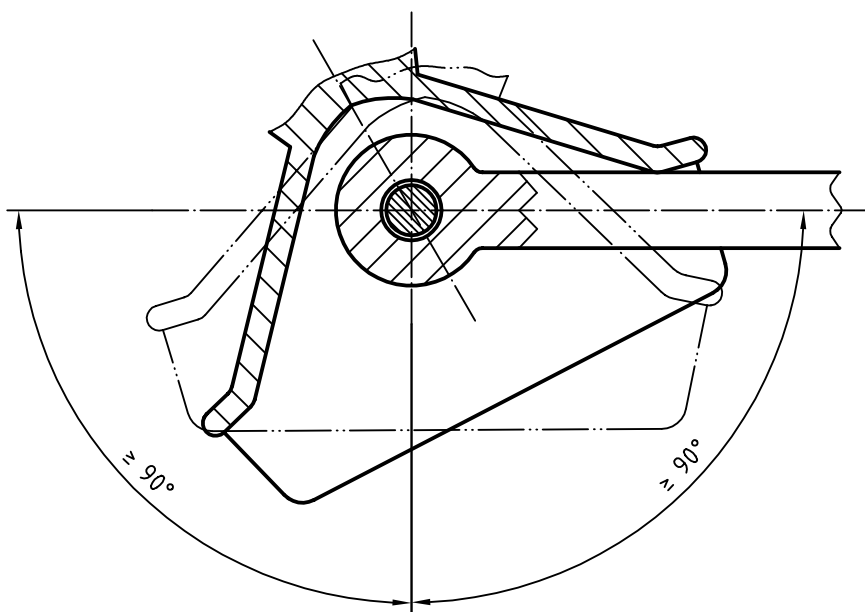

Figure 4 — Horizontal angle

5.5 Additional requirements

5.5.1 C 40 drawbar couplings

C 40 drawbar couplings shall be designed so as to permit the articulation angles described in 5.4 with drawbar eyes according to ISO 8755.

5.5.2 C 50 drawbar couplings

C 50 drawbar couplings shall be designed so as to permit the articulation angles described in 5.4 with drawbar eyes according to ISO 1102.

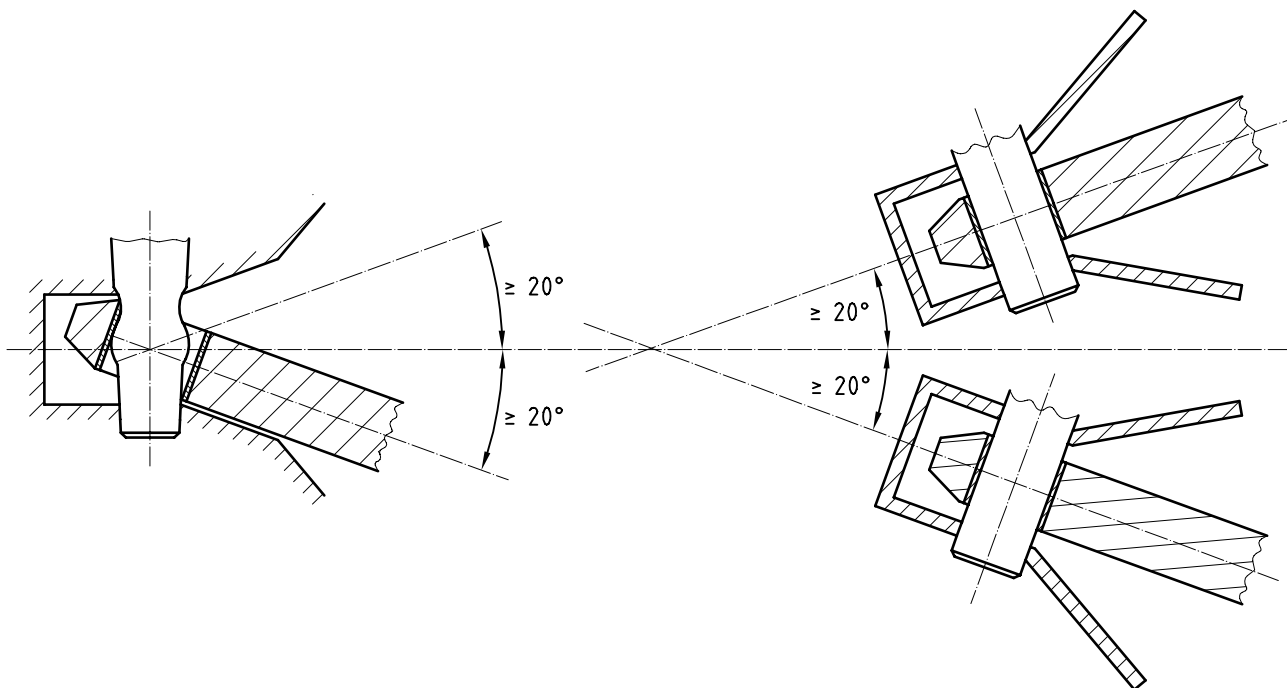

Figure 5 — Vertical angle

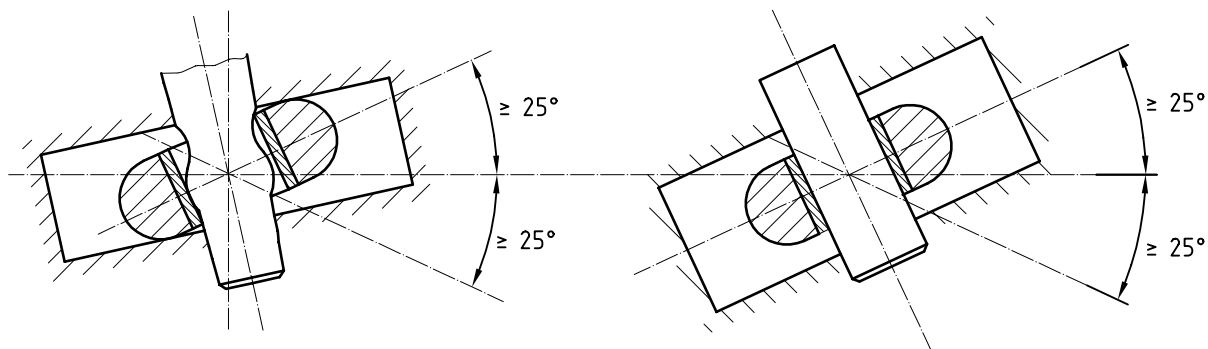

Figure 6 — Rotation angle

5.5.3 Classified C 40 and C 50 drawbar couplings

Dimensions of classified 40 mm and 50 mm drawbar couplings (see Figure 7) shall be as given in Table 4.

The couplings shall be suitable and tested for the minimum characteristic values given in Tables 5 and 6.

Table 4 — Dimensions of classified drawbar couplings

Dimensions in millimetres

Dimension		Class						
		C-1	C-2	C-3	C-4	C-5	C-6	C-7
e_1	$\pm 0,5$	83	83	120	140	160		
e_2	$\pm 0,5$	56	56	55	80	100		
d_1	max.	—	54	74	84	94		
d_2	H13	10,5	10,5	15	17	21		
f	${}^+6_0$	110	110	155	180	200		
g	± 3	85	85	90	120	140		
a	${}^{+20}_0$	100	170	200	200	200		
b	${}^{+20}_0$	150	280	360	360	360		
c	max.	20	20	24	30	30		
h	max.	150	190	265	265	265		
l_1	max.	—	150	250	300	300		
l_2	max.	150	300	330	330	330		
l_3	$\pm 20,0$	100	160	180	180	180		
T	max.	—	15	20	35	35		

Table 5 — Characteristic values for classified C 40 drawbar couplings

Characteristic value		Class				
		C40-1	C40-2	C40-3	C40-4	C40-5
D value	kN	18	25	70	100	130
D_c value	kN	18	25	50	70	90
Static load S	kg	200	250	650	900	1 000
V value	kN	12	10	18	25	35

Table 6 — Characteristic values for classified C 50 drawbar couplings

Characteristic value		Class						
		C50-1	C50-2	C50-3	C50-4	C50-5	C50-6	C50-7
D value	kN	18	25	70	100	130	190	190
D_c value	kN	18	25	50	70	90	120	130
Static load S	kg	200	250	650	900	1 000	1 000	1 000
V value	kN	12	10	18	25	35	50	75

Dimensions in millimetres

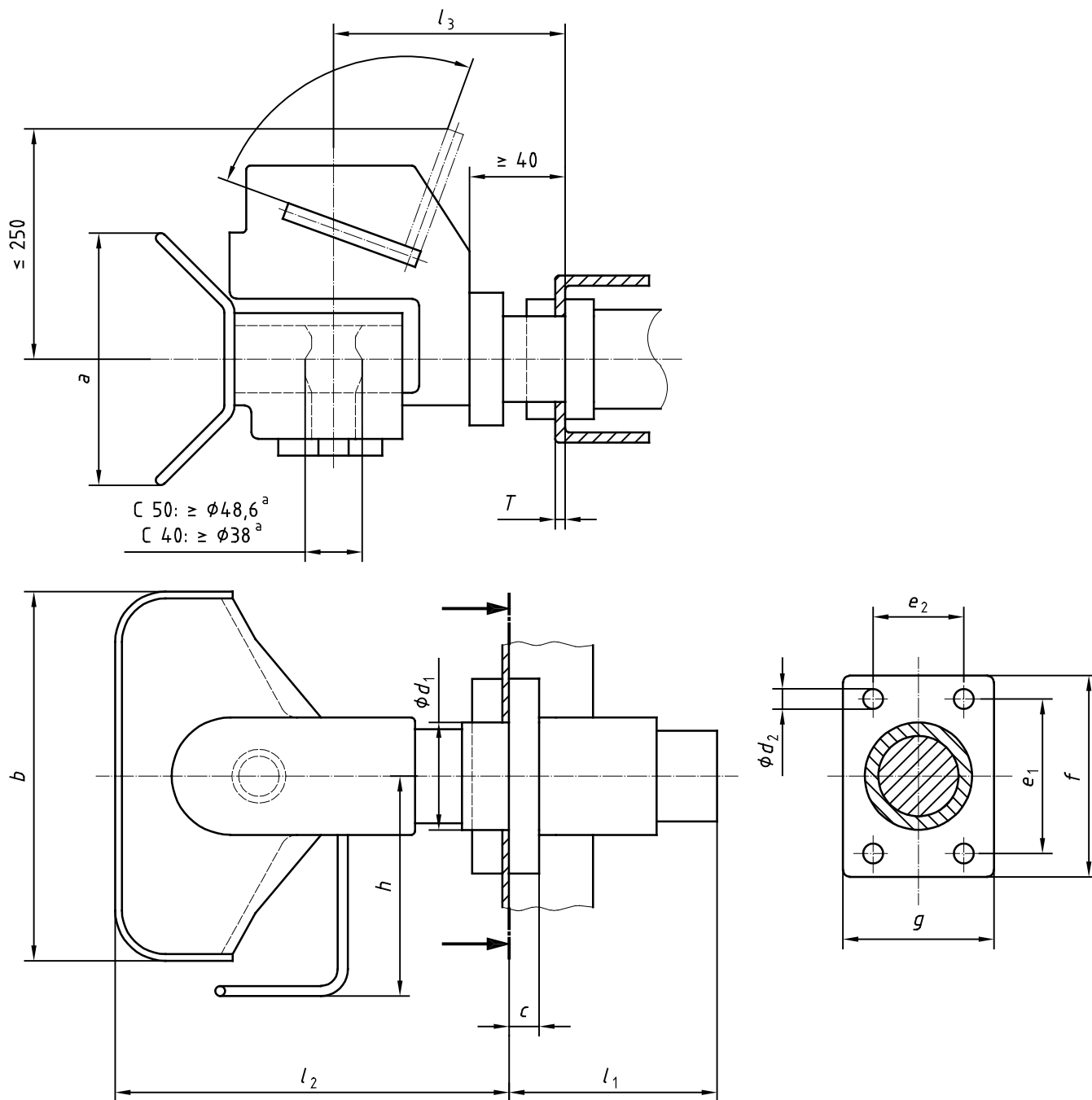

^a Maximum dimensions are limited by the provisions of 5.5.1 and 5.5.2 requiring the ability to couple drawbar eyes as specified in ISO 1102 for C 50 and ISO 8755 for C 40.

Figure 7 — Dimensions of classified drawbar couplings

Bibliography

- [1] ISO 11406, *Commercial road vehicles — Mechanical coupling between towing vehicles with rear-mounted coupling and drawbar trailers — Interchangeability*
- [2] ISO 11407, *Commercial road vehicles — Mechanical coupling between towing vehicles with coupling mounted forward and below, and centre-axle trailers — Interchangeability*

ICS 43.040.70

Price based on 10 pages

© ISO 2001 – All rights reserved