

# INTERNATIONAL STANDARD

# ISO 3560

Second edition  
2001-12-15

---

---

## Road vehicles — Frontal fixed barrier or pole impact test procedure

*Véhicules routiers — Procédure d'essai de choc frontal contre barrière fixe  
ou poteau*



Reference number  
ISO 3560:2001(E)

© ISO 2001

**PDF disclaimer**

This PDF file may contain embedded typefaces. In accordance with Adobe's licensing policy, this file may be printed or viewed but shall not be edited unless the typefaces which are embedded are licensed to and installed on the computer performing the editing. In downloading this file, parties accept therein the responsibility of not infringing Adobe's licensing policy. The ISO Central Secretariat accepts no liability in this area.

Adobe is a trademark of Adobe Systems Incorporated.

Details of the software products used to create this PDF file can be found in the General Info relative to the file; the PDF-creation parameters were optimized for printing. Every care has been taken to ensure that the file is suitable for use by ISO member bodies. In the unlikely event that a problem relating to it is found, please inform the Central Secretariat at the address given below.

© ISO 2001

All rights reserved. Unless otherwise specified, no part of this publication may be reproduced or utilized in any form or by any means, electronic or mechanical, including photocopying and microfilm, without permission in writing from either ISO at the address below or ISO's member body in the country of the requester.

ISO copyright office  
Case postale 56 • CH-1211 Geneva 20  
Tel. + 41 22 749 01 11  
Fax + 41 22 749 09 47  
E-mail [copyright@iso.ch](mailto:copyright@iso.ch)  
Web [www.iso.ch](http://www.iso.ch)

Printed in Switzerland

# Contents

Page

Foreword.....	iv
1 Scope .....	1
2 Normative references .....	1
3 Terms and definitions .....	1
4 Impact test set-up .....	4
5 Test vehicle .....	6
6 Test dummy.....	8
7 Test dummy installation.....	9
8 Impact response measurements.....	11
9 Velocity .....	12
10 Instrumentation.....	12
Bibliography .....	13

## Foreword

ISO (the International Organization for Standardization) is a worldwide federation of national standards bodies (ISO member bodies). The work of preparing International Standards is normally carried out through ISO technical committees. Each member body interested in a subject for which a technical committee has been established has the right to be represented on that committee. International organizations, governmental and non-governmental, in liaison with ISO, also take part in the work. ISO collaborates closely with the International Electrotechnical Commission (IEC) on all matters of electrotechnical standardization.

International Standards are drafted in accordance with the rules given in the ISO/IEC Directives, Part 3.

The main task of technical committees is to prepare International Standards. Draft International Standards adopted by the technical committees are circulated to the member bodies for voting. Publication as an International Standard requires approval by at least 75 % of the member bodies casting a vote.

Attention is drawn to the possibility that some of the elements of this International Standard may be the subject of patent rights. ISO shall not be held responsible for identifying any or all such patent rights.

ISO 3560 was prepared by Technical Committee ISO/TC 22, *Road vehicles*, Subcommittee SC 10, *Impact test procedures*.

This second edition cancels and replaces the first edition (ISO 3560:1975), which has been technically revised.

# Road vehicles — Frontal fixed barrier or pole impact test procedure

## 1 Scope

This International Standard specifies frontal fixed barrier and pole impact test procedures applicable to road vehicles that will ensure such tests are conducted under the same conditions.

## 2 Normative references

The following normative documents contain provisions which, through reference in this text, constitute provisions of this International Standard. For dated references, subsequent amendments to, or revisions of, any of these publications do not apply. However, parties to agreements based on this International Standard are encouraged to investigate the possibility of applying the most recent editions of the normative documents indicated below. For undated references, the latest edition of the normative document referred to applies. Members of ISO and IEC maintain registers of currently valid International Standards.

ISO 612:1978, *Road vehicles — Dimensions of motor vehicles and towed vehicles — Terms and definitions*

ISO 1176:1990, *Road vehicles — Masses — Vocabulary and codes*

ISO 3784:1976, *Road vehicles — Measurement of impact velocity in collision tests*

ISO 6487:—<sup>1)</sup>, *Road vehicles — Measurement techniques in impact tests — Instrumentation*

ISO 6549:1999, *Road vehicles — Procedure for H- and R-point determination*

SAE J211:1995, *Instrumentation for impact tests*

49 CFR, Part 572 E, *Anthropomorphic test devices — Hybrid III test dummy*, subpart E of FMVSS 208:1997, *Occupant crash protection*

## 3 Terms and definitions

For the purposes of this International Standard, the terms and definitions given in ISO 612 and the following apply.

### 3.1

#### **impact angle**

angle between the longitudinal median plane (of the vehicle) and a vertical plane perpendicular to the contact plane of the barrier face

NOTE The longitudinal median plane (of the vehicle) is also called the longitudinal plane of symmetry or zero Y plane (see ISO 4130).

---

1) To be published. (Revision of ISO 6487:2000)

**3.2**  
**vehicle width**

*W*  
distance between two planes parallel to the longitudinal median plane (of the vehicle) and touching the vehicle on either side of the longitudinal median plane

NOTE All parts of the vehicle, including any lateral projections of fixed parts (wheels, hubs, door-handles, bumpers, etc.) are contained between these two planes, except for the rear-view mirrors, side marker lamps, tyre pressure indicators, direction indicator lamps, position lights, customs seals, flexible mud-guards, door-edge guards, hinged side windows in the open position, fuel filler flaps in the open position, retractable steps, snow chains and the deflected part of the tyre walls immediately above the point of contact with the ground.

**3.3**  
**overlap**  
percentage of the vehicle width covered by the barrier face (see Figure 1)

NOTE The overlap may be left or right. Figure 1 shows a left side overlap.

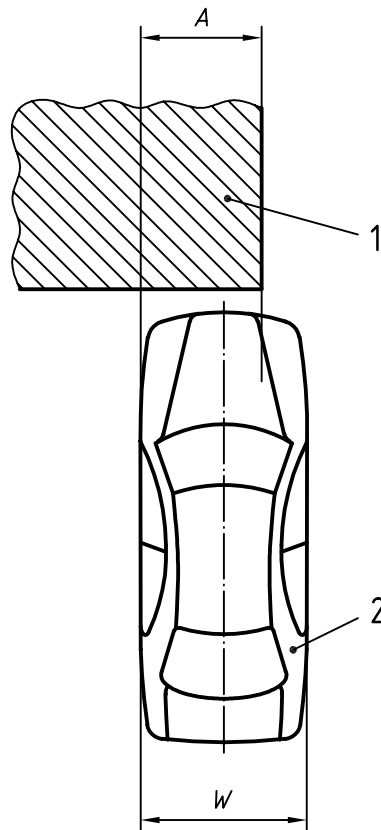

$$\text{Overlap} = \frac{A}{W} \times 100$$

- Key**
- 1 Barrier
  - 2 Vehicle

**Figure 1 — Overlap**

### 3.4 offset

*B*

perpendicular distance between the longitudinal median plane (of the vehicle) and the centreline of the pole

NOTE The offset may be left or right. Figure 2 shows a left side offset.

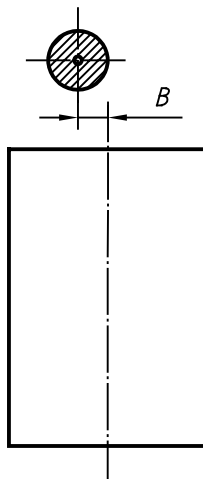

Figure 2 — Offset

### 3.5 Types of impact

#### 3.5.1 full frontal, 0° angle impact, 100 % overlap

impact in which the barrier face is wider than the impacting vehicle and the direction of travel of the vehicle is perpendicular to the barrier face

#### 3.5.2 frontal, angled impact

impact in which the barrier face is wider than the projected width of the impacting vehicle (see Figure 3) and the angle of impact is other than zero

NOTE The barrier face can be angled so that the initial contact is to the right or left of the longitudinal median plane (of the vehicle).

#### 3.5.3 offset frontal impact

impact in which the vehicle impacts a barrier face with an overlap of less than 100 %

NOTE Any angle of impact can be used.

#### 3.5.4 pole impact

impact in which the vehicle impacts a circular pole considerably narrower than the width of the vehicle

NOTE The pole can be offset to either side of the longitudinal median plane (of the vehicle).

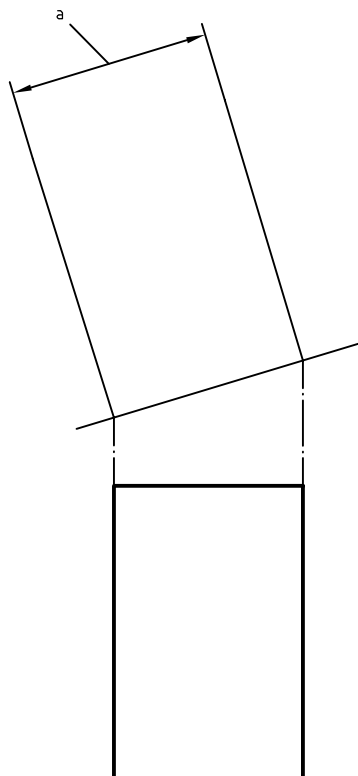

<sup>a</sup> Projected width of vehicle.

**Figure 3 — Frontal, angled impact**

## **4 Impact test set-up**

### **4.1 Test site**

The test area shall be large enough to accommodate the run-up track, barrier and technical installations necessary for the test.

The crash site surface shall be hard, horizontal, flat and smooth for a length of at least 10 m in front of the impact object. There shall be no more than a 1 % slope measured over any 1 m length for at least the last 10 m.

### **4.2 Barrier**

#### **4.2.1 Fixed barrier**

The barrier shall consist of a block of reinforced concrete at least 3 m wide and at least 1,5 m high.

The barrier shall have a mass of at least 70 000 kg. The barrier specifications given in 4.2.2 may be varied as necessary provided the barrier face is large enough to accommodate the frontal crash area of the test vehicle.

#### **4.2.2 Barrier face**

##### **4.2.2.1 General**

A variety of barrier faces may be used. Some are specified below.



#### 4.2.2.2 Flat barrier face

The barrier face shall be flat and vertical and shall be covered with fir plywood 18 mm to 26 mm thick.

#### 4.2.2.3 Anti-slide device (ASD) on flat barrier face

The ASD, which shall be 40 mm thick, 40 mm wide and at least 1 500 mm long, fabricated from steel and positioned to permit  $20 \text{ mm} \pm 2 \text{ mm}$  projection in front of the plywood, shall be mounted vertically at a distance of 350 mm left and right of the theoretical (projected) point of impact of the longitudinal median plane (of the vehicle).

#### 4.2.2.4 Deformable barrier face

The deformable barrier face shall be vertical and either flat or with a bumper simulation. It shall have sufficient height, depth and width to allow the desired test to be carried out.

The ground clearance shall be  $200 \text{ mm} \pm 5 \text{ mm}$ .

#### 4.2.2.5 Offset barrier face

The offset barrier face shall have a sufficient width to allow the desired overlap, a height of at least 1 500 mm and a depth of at least 1 000 mm. The edge radius on both sides shall be  $190 \text{ mm} \pm 2 \text{ mm}$ . The face may be set at an angle to the barrier and may include an ASD (see Figure 4).

Dimensions in millimetres

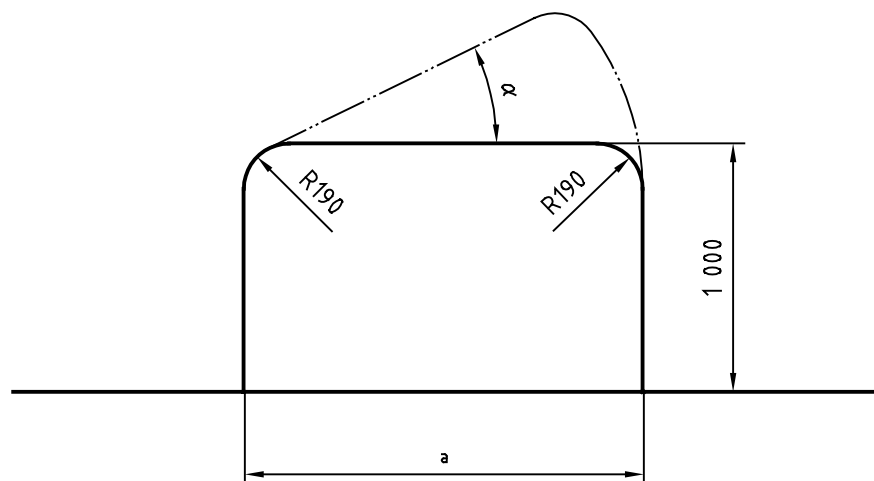

<sup>a</sup> As desired.

Figure 4 — Offset barrier face

In the case of an offset deformable barrier face, the edges of this face shall be in line with the sides of the main offset barrier and fully supported.

#### 4.2.3 Ground clearance

The tests may be conducted using a variety of barrier face ground clearances, including zero.

### 4.3 Pole

The pole, designed as a vertically-oriented, circular, rigid structure, beginning no more than 100 mm above the ground and extending above the roof of the impacting vehicle, should be 350 mm ± 10 mm in diameter and set off from any vertical mounting surface (such as attachment to a fixed rigid barrier face) by at least 1 500 mm.

The pole support shall not interfere with the crashing vehicle.

Dimensions in millimetres

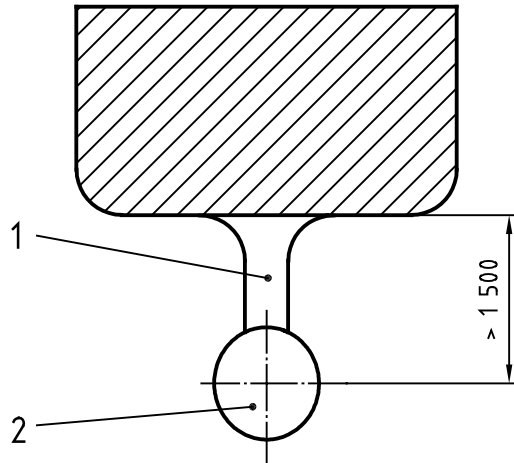

**Key**

- 1 Support
- 2 Pole

**Figure 5 — Pole**

### 4.4 Test conditions

#### 4.4.1 Propulsion of the test vehicle

The test vehicle shall be propelled to a point no closer than 0,5 m from contact with the barrier face, where it shall be released to travel freely.

The attachment to the vehicle of any external propulsion or guidance system shall not affect the vehicle's structural characteristics.

### 4.5 Alignment of the test vehicle

The test vehicle shall impact the barrier so that its longitudinal axis is within ± 2° of the intended angle of impact.

The tolerance on the offset of the impact shall not exceed ± 20 mm.

## 5 Test vehicle

### 5.1 General state and equipment

The test vehicle shall be representative of the series production, shall include all the equipment normally fitted and shall be in normal running order. Some components may be replaced by equivalent masses where this substitution clearly has no noticeable effect on the measured results.

## 5.2 Mass

Unless otherwise specified, the test vehicle mass,  $m_t$ , shall be calculated as follows:

$$m_t = m_k + m_l + m_d$$

where

$m_k$  is the complete vehicle kerb mass (ISO-M06), as defined in 4.6 of ISO 1176:1990, in kilograms;

$m_l$  is the rated cargo and luggage mass, in kilograms, equal to

$$m_p - (68 \times \text{DSC})$$

where

$m_p$  is the maximum design pay mass (ISO-M09), as defined in 4.9 of ISO 1176:1990, in kilograms,

DSC is the designated seating capacity of the test vehicle;

$m_d$  is the test dummy mass.

The vehicle shall be ballasted to achieve the test mass to within  $\pm 10$  kg. The ballast shall be located and secured to the vehicle so that it does not alter the structural characteristics of the parts of the vehicle expected to deform during the test.

At the time of impact, the vehicle shall be at the normal height and attitude defined by the manufacturer.

The instrumentation and cameras required for testing should not change the mass distribution between the axles by more than 20 kg.

It is permissible to substitute for the fuel in the fuel tank a non-flammable liquid having a density of from 0,7 kg/dm<sup>3</sup> to 1 kg/dm<sup>3</sup>.

## 5.3 Passenger compartment adjustments

### 5.3.1 Steering wheel position

The steering wheel, if adjustable, shall either be placed in the normal position as indicated by the manufacturer or midway between the limits of its range or ranges of adjustment. At the end of propelled travel, the steering wheel shall be left free, with its spoke or spokes in the position which, according to the manufacturer, corresponds to straight-ahead travel of the vehicle.

### 5.3.2 Glazing

The movable glazing of the vehicle shall be in the closed position. However, for test measurement purposes and in agreement with the manufacturer, it may be lowered, provided that the position of the operating handle corresponds to the closed position.

### 5.3.3 Gear change lever

The gear-change lever shall be in the neutral position.

### 5.3.4 Pedals

The pedals shall be in their normal position of rest.

## ISO 3560:2001(E)

### 5.3.5 Doors

The doors shall be closed but not locked.

### 5.3.6 Opening roof

If an opening or removable roof is fitted, it shall be in place and in the closed position. For test measurement purposes and in agreement with the manufacturer, it may be open.

### 5.3.7 Sun visor

The sun visors shall be in the stowed position.

### 5.3.8 Rear-view mirror

The interior rear-view mirror shall be in a normal position of use.

### 5.3.9 Armrests

Armrests at the front and rear, if movable, shall be in the position of use, unless this is prevented by the position of the test dummy or dummies in the vehicles.

### 5.3.10 Head restraints

Head restraints adjustable for height shall be in their uppermost position.

### 5.3.11 Seats

#### 5.3.11.1 Position of front seats

When using a midsized adult male dummy, seats adjustable longitudinally shall be placed so that the H-point is in the middle position of travel or in the nearest locking position rearward, and at the height position defined by the manufacturer (if independently adjustable for height).

In the case of a bench seat, the reference shall be to the H-point of the driver's place.

#### 5.3.11.2 Position of front seat-backs

If adjustable, the seat-backs shall be adjusted so that the resulting inclination of the torso of the dummy is as close as possible to that recommended by the manufacturer for normal use or, in the absence of any particular recommendation by the manufacturer, 25° towards the rear from the vertical.

#### 5.3.11.3 Rear seats

If adjustable, the rear seats or rear bench seats shall be placed in the rearmost position.

## 6 Test dummy

### 6.1 Type

A Hybrid III 50th percentile dummy shall be used (as specified in 49 CFR, part 572, subpart E of FMVSS 208:1997).

## 6.2 Clothing and shoes

The instrumented dummy shall be clothed in formfitting cotton stretch garments with short sleeves and above-the-knee length trousers as specified in FMVSS 208:1997, drawing 78051-292 and 293, or their equivalent.

A size 11XW shoe, as specified in 8.1.8.2 of FMVSS 208:1997, or equivalent, shall be placed on each foot of the test dummy.

## 6.3 Temperature

The test dummy's temperature should be within the range 20,6 °C to 22,2 °C (69 °F to 72 °F) at a relative humidity of 10 % to 70 %, after a soak period of at least 4 h prior to its use in a test.

# 7 Test dummy installation

## 7.1 General

Locate the H-point in the vehicle in accordance with ISO 6549. Using the package drawing, correlate the H-point to the seating position used for the test. Locate the lateral centreline of the seating position.

Mark the test dummy for its midsagittal plane, the centre of gravity of the head and the H-point. A hip pivot point will be marked on the dummy, or another mark will be present that approximately coincides with the ISO 6549 manikin H-point. This point should be established and marked clearly on the test dummy. Use instrumentation to measure the test dummy's pelvic angle.

The dummy's upper torso or head may be lightly taped to the seat back so that it does not move relative to the seat during final instrumentation checks, etc. The tape may be left in place for the test providing it will break when subjected to a load not exceeding 50 N.

If the positioned dummy has been placed in the seat for longer than 3 h before a test, check the head centre-of-gravity vertical position. If the head centre-of-gravity has changed by more than 6 mm, reposition the dummy.

## 7.2 Head

The transverse instrumentation platform of the head shall be horizontal to within  $\pm 2,5^\circ$ . To level the head in vehicles having upright seats with non-adjustable seat backs, adjust the position of the H-point within its limits (see 7.4), making level the instrumentation platform. If the instrumentation platform is still not level, adjust the pelvic angle within its limits (see 7.5). Then, if the instrumentation platform is still not level, adjust the neck bracket of the test dummy by the minimum amount necessary to bring the instrumentation platform within its limits.

## 7.3 Torso

### 7.3.1 In driver's position

#### 7.3.1.1 Bench seat

The upper torso of the test dummy rests against the seat back. The midsagittal plane of the test dummy is vertical and parallel to the vehicle's longitudinal centreline, and passes through the centre of the steering wheel rim. If the seat has a contour, the test dummy should be centred in the contour as determined using the ISO 6549 manikin procedure.

### 7.3.1.2 Bucket or contoured seat

The upper torso of the test dummy rests against the seat back. The midsagittal plane of the test dummy is vertical and coincides with the longitudinal centreline of the bucket or contoured seat.

### 7.3.2 In front outboard passenger position

#### 7.3.2.1 Bench seat

The upper torso of the test dummy rests against the seat back. The midsagittal plane of the test dummy is vertical and parallel to the vehicle's longitudinal centreline, and the same distance from the vehicle's longitudinal centreline as would be the midsagittal plane of a test dummy positioned in the driver position under 7.3.1. If the seat has a contour, the test dummy should be centred in the contour as determined using the ISO 6549 manikin procedure.

#### 7.3.2.2 Bucket or contoured seat

The upper torso of the test dummy rests against the seat back. The midsagittal plane of the test dummy is vertical and parallel to the vehicle's longitudinal centreline, and coincides with the longitudinal centreline of the bucket or contoured seat.

### 7.4 H-point of test dummy

The H-point of the test dummy is within 13 mm in the vertical dimension and 13 mm in the horizontal dimension with a point 6 mm below the position of the H-point as determined using the equipment and procedure specified in ISO 6549, except that the length of the lower leg and thigh segments of the H-point machine are adjusted to 414 mm and 401 mm, respectively.

### 7.5 Pelvic angle

Using the pelvic angle gauge (conforming to GM drawing 78051-532, CFR Part 572 of FMVSS 208:1997) inserted into the H-point gauging hole of the dummy, the angle measured from the horizontal on the 76,2 mm flat surface of the gauge shall be  $22,5^\circ \pm 2,5^\circ$ .

### 7.6 Thighs and legs

The thighs of the test dummy rest against the seat cushion to the extent permitted by placement of the feet. The initial distance between the outboard knee clevis flange surfaces shall be  $270 \text{ mm} \pm 10 \text{ mm}$ . To the extent practicable, the left leg of the test dummy in the driver's position and both legs of the test dummy in the outboard passenger position are in vertical longitudinal planes. To the extent practicable, the right leg of the driver dummy shall be in a vertical plane. Final adjustment to accommodate placement of feet in accordance with 7.9 for various passenger compartment configurations is permitted.

### 7.7 Arms

#### 7.7.1 In driver's position

The upper arms shall be adjacent to the torso with the centrelines as close to the vertical plane as possible.

#### 7.7.2 In front outboard passenger position

The upper arms shall be in contact with the seat back and the sides of the torso.

## 7.8 Hands

### 7.8.1 In driver's position

The palms shall be in contact with the outer part of the steering wheel rim at the rim's horizontal centreline. The thumbs shall be over the steering wheel rim and shall be lightly taped to the rim, so that if the hand is pushed upward by a force of not less than 9 N and not greater than 22 N, the tape will release the hand from the steering wheel rim.

### 7.8.2 In front outboard passenger position

The palms shall be in contact with the outside of the thighs. The little finger shall be in contact with the seat cushion.

## 7.9 Feet

### 7.9.1 In driver's position

The right foot of the test dummy rests on the undepressed accelerator with the heel resting as far forward as possible on the floorpan. The left foot is set perpendicular to the leg and placed as far forward as possible such that the heel rests on the floorpan.

### 7.9.2 In front outboard passenger position

The feet of the test dummy are placed on the vehicle's toe board with the heels resting on the floorpan as close as possible to the intersection of the toe board and floorpan. If the feet cannot be placed flat on the toe board, they are set perpendicular to the legs and placed as far forward as possible such that the heels rest on the floorpan.

## 8 Impact response measurements

Measurement data and acquisitions shall be in accordance with ISO 6487 and SAE J211.

The dummy measurements shall be as follows.

- Head: 3 axis acceleration at the CG
- Upper neck:  $F_x, F_z, F_y + M_x, M_y, M_z$
- Chest: 3 axis acceleration  
Deflection  $D_x$
- Thoracic spine: lower  $F_x, F_z, M_y$
- Lumbar spine: lower  $F_x, F_z, M_y$
- Pelvis: 3 axis acceleration  
submarining indicator
- Femur:  $F_z$
- Lower tibia:  $F_x, F_z, M_x, M_y$
- Upper tibia:  $F_x, F_z, M_x, M_y$

## 9 Velocity

The velocity of the vehicle shall be measured within 0,5 m prior to impact in a manner specified in ISO 3784.

The velocity at the time of impact shall be that specified in the applicable test requirements. The impact velocity tolerance shall be  $\pm 0,5$  km/h the desired velocity.

## 10 Instrumentation

All measurements should be recorded and filtered according to ISO 6487 and SAE J211. These measurements should be continuous functions of time.



## Bibliography

- [1] ISO 4130, *Road vehicles — Three-dimensional reference system and fiducial marks — Definitions*
- [2] ISO 6813, *Road vehicles — Collision classification — Terminology*

.....

---

---

**ICS 43.020**

Price based on 13 pages

© ISO 2001 – All rights reserved