

INTERNATIONAL STANDARD

ISO
3545-1

First edition
1989-12-01

Steel tubes and fittings — Symbols for use in specifications —

Part 1: Tubes and tubular accessories with circular cross-section

*Tubes et raccords en acier — Symboles à utiliser dans les spécifications —
Partie 1: Tubes et accessoires de forme tubulaire à section circulaire*



Reference number
ISO 3545-1 : 1989 (E)

Foreword

ISO (the International Organization for Standardization) is a worldwide federation of national standards bodies (ISO member bodies). The work of preparing International Standards is normally carried out through ISO technical committees. Each member body interested in a subject for which a technical committee has been established has the right to be represented on that committee. International organizations, governmental and non-governmental, in liaison with ISO, also take part in the work. ISO collaborates closely with the International Electrotechnical Commission (IEC) on all matters of electrotechnical standardization.

Draft International Standards adopted by the technical committees are circulated to the member bodies for approval before their acceptance as International Standards by the ISO Council. They are approved in accordance with ISO procedures requiring at least 75 % approval by the member bodies voting.

International Standard ISO 3545-1 was prepared by Technical Committee ISO/TC 5, *Ferrous metal pipes and metallic fittings*.

This first edition of ISO 3545-1 cancels and replaces ISO 3545 : 1981 of which it constitutes a minor revision.

ISO 3545 consists of the following parts, under the general title *Steel tubes and fittings* — *Symbols for use in specifications*:

- *Part 1: Tubes and tubular accessories with circular cross-section*
- *Part 2: Square and rectangular hollow sections*
- *Part 3: Tubular fittings with circular cross-section*

© ISO 1989

All rights reserved. No part of this publication may be reproduced or utilized in any form or by any means, electronic or mechanical, including photocopying and microfilm, without permission in writing from the publisher.

International Organization for Standardization
Case postale 56 • CH-1211 Genève 20 • Switzerland

Printed in Switzerland

Steel tubes and fittings — Symbols for use in specifications —

Part 1 :

Tubes and tubular accessories with circular cross-section

1 Scope

This part of ISO 3545 defines the most common symbols with the aim of standardizing and facilitating the use of terminology in standards for steel tubes and associated products.

2 Fundamental symbols (see figure 1)

D = specified outside diameter

P = pressure

T = specified thickness

M = mass per unit length

3 Symbols for service conditions

DN = nominal size

PN = nominal pressure

PS = service pressure

TS = service temperature

4 Symbols for tolerances

See ISO 5252 : 1977, *Steel tubes — Tolerance systems*.

5 Symbols for tests

5.1 Pressure test

PE = test pressure

S = stress which occurs in the metal during the test

5.2 Flattening test (see figure 2)

H = distance between the platens of the test machine

L = length of the test piece

K = constant factor of deformation for the formula

$$H = \frac{(1 + K) \times T}{K + (T/D)}$$

5.3 Drift expanding test (see figure 3)

C = outside diameter of expansion

L = length of test piece before testing

5.4 Flanging test (see figure 4)

C = outside flange diameter

L = length of test piece before testing

6 Symbols for specifications

I = moment of inertia¹⁾ (second moment of area)

$$I = \frac{\pi}{64} [D^4 - (D - 2T)^4]$$

W = section modulus = $\frac{I}{D/2}$

A = section²⁾ = $\pi(D - T)T$

i = radius of gyration = $\sqrt{\frac{I}{A}}$

B = diameter-thickness ratio = $\frac{D}{T}$

O = ovality = difference between the maximum and the minimum outside diameter in the same cross-section divided by the outside diameter. The ovality is expressed as a percentage (see figure 5).

$$O = 100 \times \frac{D_{\max} - D_{\min}}{D}$$

E = eccentricity = difference between the maximum and the minimum thickness in the same cross-section divided by the thickness. The eccentricity is expressed as a percentage (see figure 6).

$$E = 100 \times \frac{T_{\max} - T_{\min}}{T}$$

1) The moment of inertia is calculated on the basis of any axis.

2) This is a cross-sectional area which is perpendicular to the axis of the tube or the accessory.

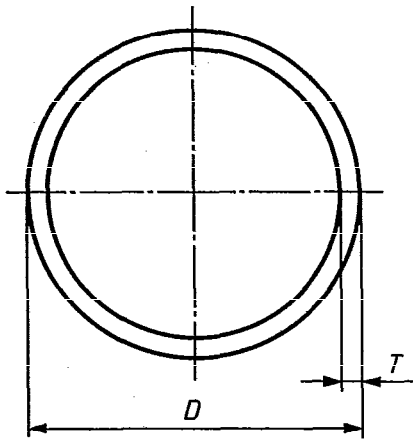

Figure 1

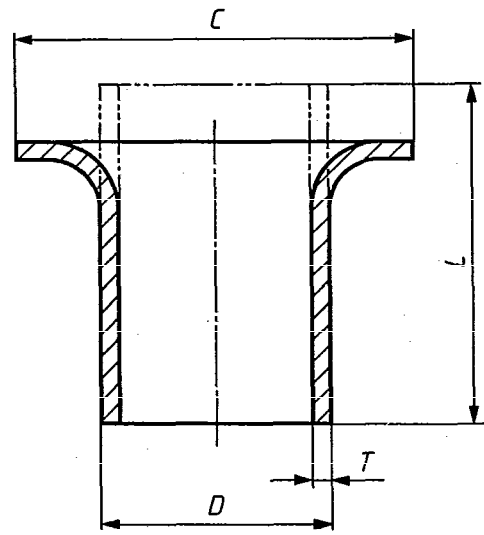

Figure 4

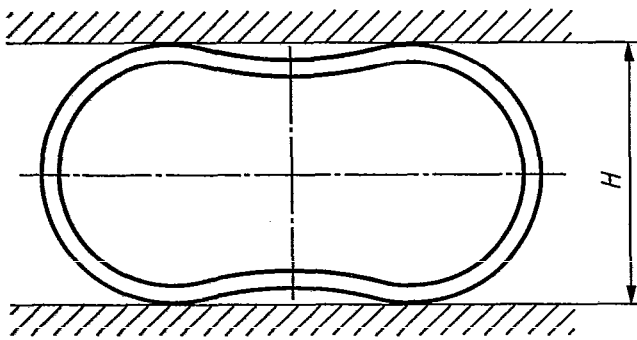

Figure 2

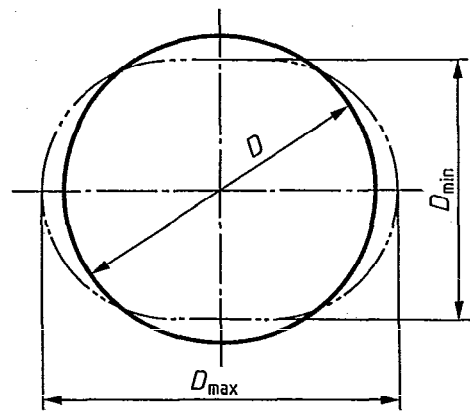

Figure 5

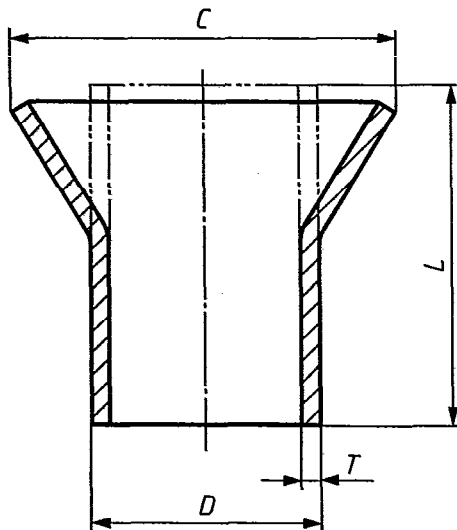

Figure 3

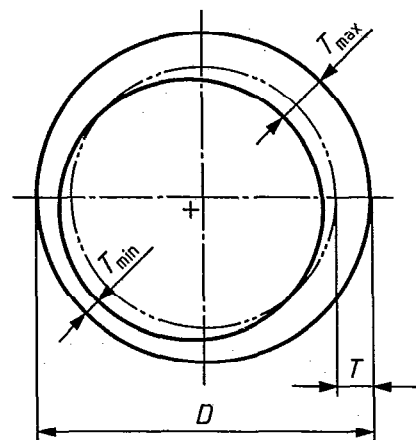

Figure 6

ISO 3545-1 : 1989 (E)

UDC [621.643.2 + 621.643.06]-034.14

Descriptors: metal tubes, steel tubes, accessories, circular form, symbols.

Price based on 3 pages
