

INTERNATIONAL
STANDARD

ISO
3536

Third edition
2016-06-01

**Road vehicles — Safety glazing
materials — Vocabulary**

Véhicules routiers — Vitrages de sécurité — Vocabulaire



Reference number
ISO 3536:2016(E)

© ISO 2016



COPYRIGHT PROTECTED DOCUMENT

© ISO 2016, Published in Switzerland

All rights reserved. Unless otherwise specified, no part of this publication may be reproduced or utilized otherwise in any form or by any means, electronic or mechanical, including photocopying, or posting on the internet or an intranet, without prior written permission. Permission can be requested from either ISO at the address below or ISO's member body in the country of the requester.

ISO copyright office
Ch. de Blandonnet 8 • CP 401
CH-1214 Vernier, Geneva, Switzerland
Tel. +41 22 749 01 11
Fax +41 22 749 09 47
copyright@iso.org
www.iso.org

Contents

Page

Foreword	iv
1 Scope	1
2 Terms and definitions	1

Foreword

ISO (the International Organization for Standardization) is a worldwide federation of national standards bodies (ISO member bodies). The work of preparing International Standards is normally carried out through ISO technical committees. Each member body interested in a subject for which a technical committee has been established has the right to be represented on that committee. International organizations, governmental and non-governmental, in liaison with ISO, also take part in the work. ISO collaborates closely with the International Electrotechnical Commission (IEC) on all matters of electrotechnical standardization.

The procedures used to develop this document and those intended for its further maintenance are described in the ISO/IEC Directives, Part 1. In particular the different approval criteria needed for the different types of ISO documents should be noted. This document was drafted in accordance with the editorial rules of the ISO/IEC Directives, Part 2 (see www.iso.org/directives).

Attention is drawn to the possibility that some of the elements of this document may be the subject of patent rights. ISO shall not be held responsible for identifying any or all such patent rights. Details of any patent rights identified during the development of the document will be in the Introduction and/or on the ISO list of patent declarations received (see www.iso.org/patents).

Any trade name used in this document is information given for the convenience of users and does not constitute an endorsement.

For an explanation on the meaning of ISO specific terms and expressions related to conformity assessment, as well as information about ISO's adherence to the World Trade Organization (WTO) principles in the Technical Barriers to Trade (TBT) see the following URL: www.iso.org/iso/foreword.html.

The committee responsible for this document is ISO/TC 22, *Road vehicles*, Subcommittee SC 35, *Lighting and visibility*.

This third edition cancels and replaces the second edition (ISO 3536:1999), which has been technically revised.

Road vehicles — Safety glazing materials — Vocabulary

1 Scope

This International Standard defines terms relating to safety glazing materials for road vehicles.

2 Terms and definitions

For the purposes of this document, the following terms and definitions apply.

2.1

safety glazing material

glazing material consisting of organic and/or inorganic materials so constructed or treated to minimize the likelihood of injury to persons as a result of contact with these safety glazing materials when used in a vehicle and which complies with specified requirements for visibility, strength, and durability

2.2

toughened safety glass

glazing material consisting of a single layer of glass which has been subjected to special thermal or chemical treatment to increase its mechanical strength and to condition its fragmentation after shatter

2.3

laminated safety glass

glazing material consisting of two or more layers of glass held together by one or more *interlayers* (2.4)

Note 1 to entry: The following two types are recognized:

- ordinary: when none of the layers of glass, of which it is composed, has been treated, i.e. normal annealed glass;
- treated: when at least one of the layers of glass, of which it is composed, is *toughened safety glass* (2.2) or glass which has been treated in any controlled process in order to give it increased resistance to mechanical and thermal stress.

2.4

interlayer

plastic material designed to be used to permanently bond together the component layers of *laminated safety glass* (2.3)

2.5

glass-plastic glazing material

glazing material which may comprise one layer of glass and one or more layers of plastic in which a plastic surface faces inward towards the vehicle passenger compartment when installed in the vehicle

2.6

plastic safety glazing material

safety glazing material (2.1) that contains, as an essential ingredient, one or more layers of organic polymeric substances

Note 1 to entry: The following two types are recognized:

- rigid plastic: organic polymeric material which maintains its structural stiffness over the intended use range;
- flexible plastic: organic polymeric material which remains conformable over the intended use range.

2.7
double glazed unit
assembly of two glazing materials permanently assembled in manufacture and separated by a uniform gap

Note 1 to entry: The following two types are recognized:

- symmetrical: where the two components are identical, e.g. both toughened glass;
- asymmetrical: where the two components are not identical, e.g. one unit is toughened glass and the other is laminated glass, or where the two components are not of the same thickness.

2.8
double window
assembly of two individual glazing materials separately installed within the same opening in the vehicle

2.9
safety glass faced with plastics
uniformly *toughened safety glass* (2.2) or *laminated safety glass* (2.3) with a layer of plastic on the inner side,

EXAMPLE The side facing towards the vehicle passenger compartment.

2.10
security glazing
type of glazing which gives a certain level of protection from manual attack from the outside of the vehicle

2.11
vision area
part of the installed *safety glazing material* (2.1) which shall satisfy special optical requirements and which is used in driving the vehicle

2.12
primary vision area
part of the *vision area* (2.11) immediately in front of the driver, through which pass the driver's principal directions of vision

2.13
optical deviation
angle of deviation
angle between the incident ray and the emergent ray refracted by the *safety glazing material* (2.1)

2.14
wedge
departure from parallelism of the surfaces of the *safety glazing material* (2.1) that may be inherent in the basic product or may result from techniques employed in producing the designed geometry

2.15
luminous transmittance
 $T(\lambda)$
ratio of the transmitted luminous flux, F , which has passed through the glazing material to the incident luminous flux, F_0 , normal (perpendicular) to the surface, either at a specified wavelength, λ , of light or for a specified illumination source:

$$T = F/F_0$$

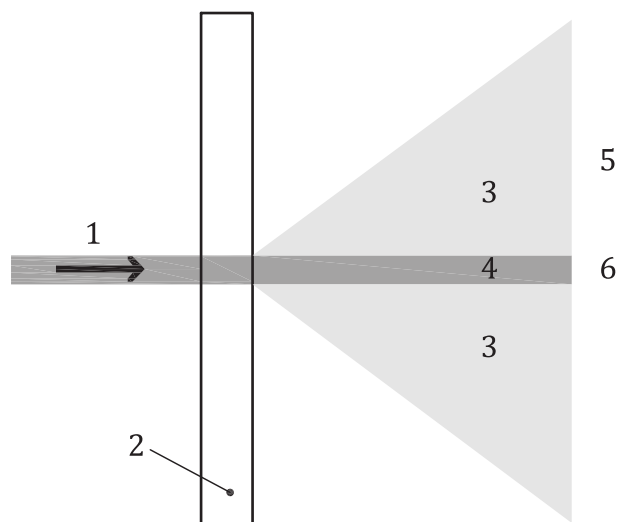
**Key**

- 1 incident light beam with flux Φ_o
- 2 glazing sample
- 3 diffuse transmitted light
- 4 regular transmitted light

5 diffuse transmitted flux Φ_d ; $T_d = \frac{\Phi_d}{\Phi_o}$

6 regular transmitted flux Φ_r ; $T_r = \frac{\Phi_r}{\Phi_o}$

Note 1 to entry: The following two types are recognized:

- diffuse luminous transmittance, which is the ratio of transmitted diffuse (scattered) light flux to the incident flux;
- regular luminous transmittance, which is the ratio of transmitted non-diffuse (non-scattered) light flux to the incident flux.

2.16**secondary image**

spurious or ghost image, visible near but dimmer than the primary image, usually seen at night when the object being viewed is very bright in relation to its surroundings

EXAMPLE The headlights of an approaching vehicle.

2.17**optical distortion**

vehicle occupant's perception that, when looking through *safety glazing material* (2.1), outside objects appear to have an anomalous shape or objects in smooth motion appear to have an irregular motion

2.18**luminous reflectance**

ratio of the reflected luminous flux to the incident luminous flux either at a specified wavelength, λ , of light or for a specified illumination source

Note 1 to entry: See also 2.15.

2.19**bullet resistant glazing material**

glazing material constructed to be resistant to firearms

2.20

design glazing outline

design maximum unobstructed vehicle aperture designated to be glazed, before the glazing material is installed or mounted, including all trims, but excluding opaque obscuration

2.21

height of segment "h"

maximum distance, measured at right angles to the glazing material, separating the inner surface of the glazing material from a plane passing through the ends of the glazing material

$$\text{height of segment "h"} = h_{1\text{maximum}} + h_{2\text{maximum}}$$

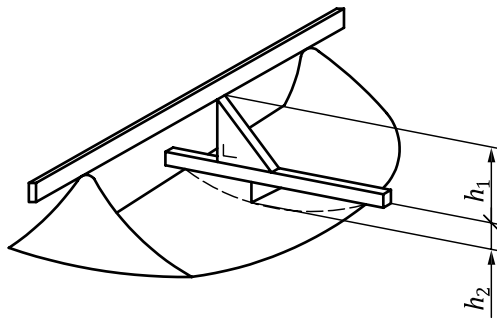

2.22

curved pane

pane (2.32) with a height of segment "h" (2.21) greater than 10 mm per linear metre

2.23

flat pane

pane (2.32) with a height of segment "h" (2.21) equal to or less than 10 mm per linear metre

2.24

radius of curvature "r"

smallest radius of arc of the glazing material as measured in the most curved area

2.25

rake (installation) angle

angle between a vertical line and a straight line passing through the top and bottom edges of the inner side of the glazing material, when both lines are contained in the vertical plane through the longitudinal axis of the vehicle

2.26

test specimen

test piece

sample or a finished product of glazing material

2.27

shade band

portion of the glazing material with a reduced light transmission, whether solid tint or dot printed, to reduce solar glare for occupant comfort

2.28

opaque obscuration

portion of the glazing material preventing light transmission along the glazing periphery to prevent degradation of the attaching adhesive and to mask that adhesive and underlying body components or around the position of the interior rear-view mirror to mask the mirror base or parts of any underlying sensors or other elements

2.29**transparent area of the windscreen**

glazing area contained within the design glass outline, excluding any allowed *opaque obscuration* ([2.28](#)), but including any *shade band* ([2.27](#))

2.30**head injury criteria****HIC**

calculation of the injury level which result from a blunt perpendicular impact with the glazing material

2.31**windscreen**

glazing in front of the driver through which the driver views the road ahead

2.32**pane**

any single piece of glazing other than *windscreen* ([2.31](#)), to the exclusion however of glazing for lighting and light-signalling devices and instrument panels

