

---

International Standard



3511/3

---

INTERNATIONAL ORGANIZATION FOR STANDARDIZATION • МЕЖДУНАРОДНАЯ ОРГАНИЗАЦИЯ ПО СТАНДАРТИЗАЦИИ • ORGANISATION INTERNATIONALE DE NORMALISATION

---

**Process measurement control functions and  
instrumentation — Symbolic representation —  
Part 3: Detailed symbols for instrument interconnection  
diagrams**

*Fonctions et instrumentations pour la mesure et la régulation des processus industriels — Représentation symbolique —  
Partie 3: Symboles détaillés pour les diagrammes d'interconnexion d'instruments*

First edition — 1984-07-01

---

UDC 744.43 : 62-52 : 003.62

Ref. No. ISO 3511/3-1984 (E)

**Descriptors** : technical drawings, graphic symbols, measuring instruments, control devices, control functions.

Price based on 19 pages

## Foreword

ISO (the International Organization for Standardization) is a worldwide federation of national standards bodies (ISO member bodies). The work of developing International Standards is carried out through ISO technical committees. Every member body interested in a subject for which a technical committee has been authorized has the right to be represented on that committee. International organizations, governmental and non-governmental, in liaison with ISO, also take part in the work.

Draft International Standards adopted by the technical committees are circulated to the member bodies for approval before their acceptance as International Standards by the ISO Council.

International Standard ISO 3511/3 was developed by Technical Committee ISO/TC 10, *Technical drawings*, and was circulated to the member bodies in July 1983.

It has been approved by the member bodies of the following countries:

Australia	India	Sweden
Austria	Netherlands	Switzerland
Belgium	New Zealand	United Kingdom
Finland	Poland	USA
Germany, F.R	Spain	USSR

The member body of the following country expressed disapproval of the document on technical grounds:

Italy

This part of ISO 3511 was developed by sub-committee 3, *Graphical symbols for instrumentation*. The symbols are intended to be used to represent functions and, in special cases, equipment on technical drawings such as schematic diagrams or process flow-diagrams. However, this field of engineering is closely related to electrical instrumentation dealt with by IEC/TC 65 or in part by IEC/SC 3A. For this reason there has been close coordination in a joint working group and the results were accepted by members of ISO and IEC.

# Process measurement control functions and instrumentation — Symbolic representation — Part 3: Detailed symbols for instrument interconnection diagrams

## 0 Introduction

This International Standard has been devised to provide a universal means of communication among the various interests involved in the design, manufacture, installation and operation of measurement and control equipment used in the process industries.

Requirements within the industries vary considerably; in recognition of this, this International Standard is presented in four parts as follows:

Part 1: Basic requirements (directed towards the needs of those employing comparatively simple measurements and control means).

Part 2: Extension of basic requirements.

Part 3: Detailed symbols for instrument interconnection diagrams.

Part 4: Basic symbols for process computer, interface, and shared display/control functions.<sup>1)</sup>

The four parts together are intended to:

a) meet the requirements of those who, possibly employing more sophisticated measurement and control means, may wish to depict such aspects as the measurement techniques embodied in a particular instrument, or the means — hydraulic, pneumatic, electrical, mechanical — used for its actuation;

b) provide standard symbolic representation for process measurement control functions and instrumentation. These symbols are not intended to replace graphic symbols for electrical equipment as contained in IEC Publication 117, *Recommended graphical symbols; graphical symbols*.

## 1 Scope and field of application

This part of ISO 3511 specifies instrument symbols for use on interconnection diagrams used for the design, installation, and maintenance of process measurement and control systems.

These detailed symbols are not normally intended for drawings that use the functional symbols given in ISO 3511/1 and ISO 3511/2. However, the symbols specified in this part of ISO 3511 show, by detailing the components, the external connections between units of equipment.

Information on the internal connections in units is not normally included, but references to the appropriate circuit or wiring diagrams may be provided.

When an instrument is composed of more than one functional part, the different symbols may be combined, for example, recorder controller.

The dimensions of the symbols are unspecified, provided the ratio of the side lengths is maintained according to this part of ISO 3511.<sup>2)</sup>

If not otherwise stated, contact symbols should be shown open.

The diagrams may employ single line or multi-line representation and may be combined with, or replaced by tables, providing clarity is maintained.

For further assistance, see IEC Publication 113 Part 5, *Preparation of interconnection diagrams and tables*.

## 2 Definitions

The following definitions are used solely for the purposes of this part of ISO 3511, to assist in the application and understanding of the symbol system.

1) At present at the stage of draft.

2) This rule has been adopted provisionally until such time as technical committee ISO/TC 10 prepares an International Standard for the representation of graphical symbols used on technical drawings.

**2.1 point of measurement:** The point in a process at which a measurement is or may be made.

**2.2 instrument:** A device or combination of devices used directly or indirectly to measure, display and/or control a variable. This term does not apply to internal components of the instruments, for example resistor or receiver bellows.

**2.3 panel-mounted instrument:** An instrument that is mounted in a group normally accessible to the operator.

**2.4 locally mounted instrument:** An instrument that is not panel-mounted.

**2.5 correcting unit:** The unit comprising those elements (actuating and correcting) which adjust the correcting conditions, in response to a signal from the controller.

**2.6 actuating element:** That part of the correcting unit which adjusts the correcting element, for example a response to a signal from the controller.



**2.7 correcting element:** That part of the correcting unit which directly adjusts the value of the correcting conditions.



**2.8 alarm:** A device which is intended to attract attention to a defined abnormal condition by means of a discrete audible and/or visible signal, but which does not itself institute corrective action.

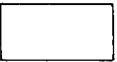
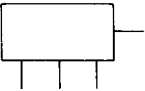

**2.9 set value:** The value of the controlled condition to which the controller is set.

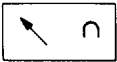
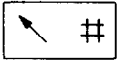
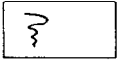
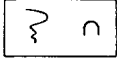
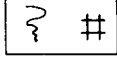
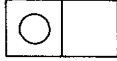
**2.10 interconnection diagram:** Diagram representing the connections between the different units of an installation.

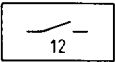
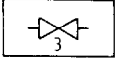
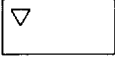
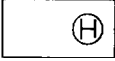
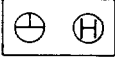

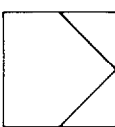
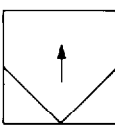
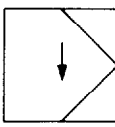
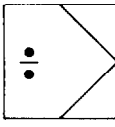

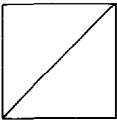

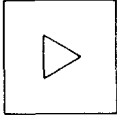
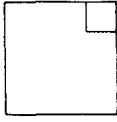
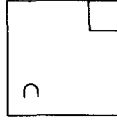
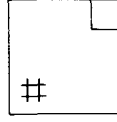
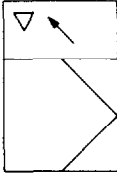
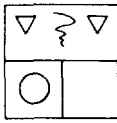
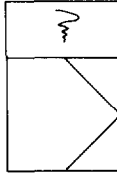

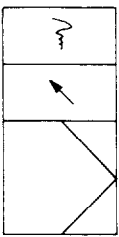
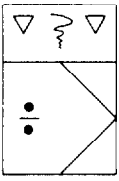
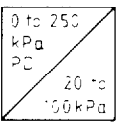
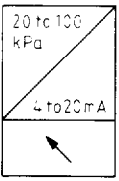
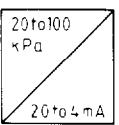
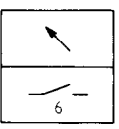
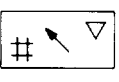
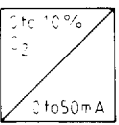
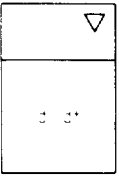

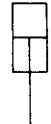

### 3 Symbols

No.	Description	Use of equipment or explanation of symbol	Symbol
3.1	Instruments		
3.1.1	Non-converting instruments	Examples: indicators, recorders, counters	
3.1.1.1	Basic symbol	Preferred ratio of sides 1 : 2	
3.1.1.1.1	Basic symbol with connections	Terminals may be placed on any basic symbol	
3.1.1.2	Indicator	Arrow points upwards to left	
3.1.1.2.1	Analogue indicator		
3.1.1.2.2	Digital indicator		
3.1.1.3	Recorder	State number of records if more than one	
3.1.1.3.1	Analogue recorder		
3.1.1.3.2	Digital recorder		
3.1.1.4	Counter		

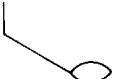
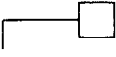
No.	Description	Use of equipment or explanation of symbol	Symbol
3.1.1.5	Measuring point selection switch (electrical)	State number of measuring points (for example, 12 points)	
3.1.1.6	Measuring point selection valve (gas or liquid)	State number of measuring points (for example, 3 points)	
3.1.1.7	Switch for alarm signal or initiator	<p><b>Position</b>                      <b>Input</b></p> <p>Left                                = minimum</p> <p>Right                               = maximum</p> <p>If symbol is turned 90°,</p> <p>Lower                               = minimum</p> <p>Upper                               = maximum</p>	
3.1.1.8	Manual control station		
3.1.1.9	Manual control station with hand/auto or remote/local switch		
3.1.2	Converting instruments	Examples: transmitters, controllers, relays	
3.1.2.1	Basic symbol	Preferred ratio of sides 1 : 1	
3.1.2.1.1	Basic symbol with connections	Terminals may be placed on any basic symbol	
3.1.2.2	Controller, closed-loop	The apex of the inscribed V is on the output-signal side. The apex angle shall be 90°.	
3.1.2.3	Controller with increasing input signal giving increasing output signal	When symbol is turned, the arrow indicating the direction of output action shall remain in the vertical up position	
3.1.2.4	Controller with increasing input signal giving decreasing output signal	When symbol is turned, the arrow indicating the direction of output action shall remain in the vertical down position.	
3.1.2.5	Ratio controller		







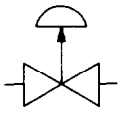
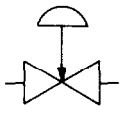
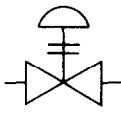
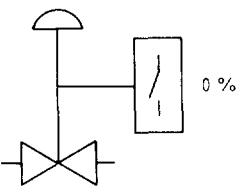
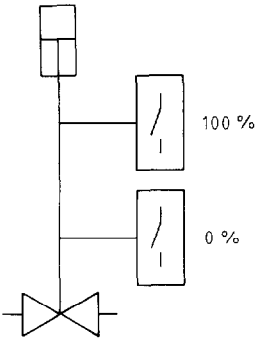
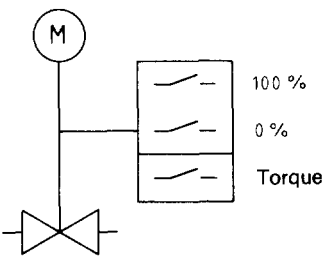

No.	Description	Use of equipment or explanation of symbol	Symbol
3.1.2.6	Converter, transmitter, transducer, etc.	State type and range of input and output signals	
3.1.2.7	Computing relay	State computing function: $+$ , $-$ , $\times$ , $\times^n$ , $\int$ , $\frac{d}{dt}$ , $\sqrt{\quad}$ , etc. For example, square root extractor	
3.1.2.8	Amplifier		
3.1.2.9	Signal memory		
3.1.2.9.1	Analogue signal memory		
3.1.2.9.2	Digital signal memory		
3.1.3	Logic elements		In accordance with IEC Publication 117, Part 15
3.1.4	Examples of instruments		
3.1.4.1	Indicating controller with switch for minimum signal		
3.1.4.2	Recorder and counter with switches for minimum and maximum signal		
3.1.4.3	Recording controller		

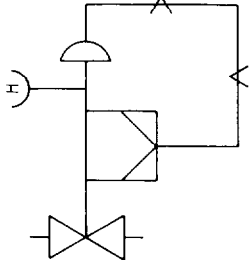
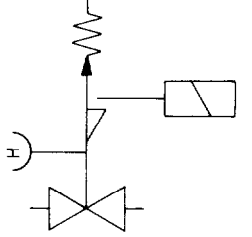

No.	Description	Use of equipment or explanation of symbol	Symbol
3.1.4.4	Indicating controller with recorder for second measured variable		
3.1.4.5	Recording ratio controller with switches for minimum and maximum signal		
3.1.4.6	Transmitter: <ul style="list-style-type: none"> <li>- input, 0 to 250 kPa differential pressure;</li> <li>- output, 20 to 100 kPa standard signal</li> </ul>		
3.1.4.7	Signal converter with output indicator: <ul style="list-style-type: none"> <li>- input, 20 to 100 kPa;</li> <li>- output, 4 to 20 mA</li> </ul>		
3.1.4.8	Signal converter: <ul style="list-style-type: none"> <li>- input, 20 to 100 kPa;</li> <li>- output, 20 to 4 mA</li> </ul>		
3.1.4.9	Indicator with selector switch for 6 measuring points		
3.1.4.10	Digital indicator with switch for maximum signal		
3.1.4.11	Oxygen transmitter: <ul style="list-style-type: none"> <li>- input 0 to 10 % O<sub>2</sub>;</li> <li>- output 0 to 50 mA</li> </ul>		
3.1.4.12	Rate-of-change relay with high-rate switch		

No.	Description	Use of equipment or explanation of symbol	Symbol
3.2	Correcting units		
3.2.1	Correcting elements		
3.2.1.1	Valve	If type of valve is to be shown, the relevant ISO symbol shall be used	
3.2.2	Actuating element	A vertical line shall be connected to the correcting element symbol	
3.2.2.1	Manual actuator		
3.2.2.2	Diaphragm actuator		
3.2.2.3	Solenoid actuator	Preferred side relationship 1 : 2	
3.2.2.4	Piston actuator	Preferred side relationship 1 : 2	
3.2.2.5	Rotary motor actuator		
3.2.2.6	Spring actuator		
3.2.2.7	Float actuator		
3.2.2.8	Weight actuator		
3.2.2.9	Centrifugal force actuator		
3.2.3	Accessories		
3.2.3.1	Lock-up to block movement to the left	The separate vertical line should connect to the symbol for an actuator such as a solenoid	
3.2.3.2	Lock-up initially permitting movement to left and right, but which blocks return to left after movement to right	The separate vertical line should connect to the symbol for an actuator such as a solenoid	
3.2.3.3	Limit switch	"Make" contact, closed when actuated	
3.2.3.4	Limit switch	"Break" contact, open when actuated	



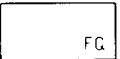
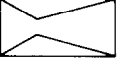
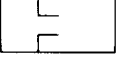
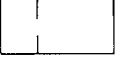

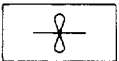
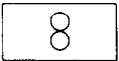
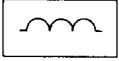
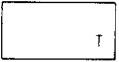
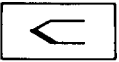
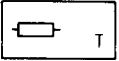
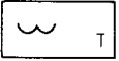

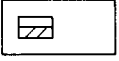
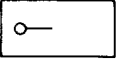
No.	Description	Use of equipment or explanation of symbol	Symbol
3.2.3.5	Correcting element takes fail-safe position when actuation energy fails	Opens on failure	
		Closes on failure	
		Retains position on failure	
3.2.4	<p>Examples of correcting-unit assemblies. When confusion may occur between mechanical and electrical connections, a double line may be used for mechanical connections. Switches shall be shown in non-actuated position. Orientation of switch symbol is optional.</p>		
3.2.4.1	Correcting units with integrally mounted switches		
3.2.4.1.1	Control valve with diaphragm actuator with integrally mounted switch actuated in valve-closed (0 %) position. Contact closes when switch is actuated.		
3.2.4.1.2	Control valve with piston actuator with integrally mounted switches actuated in valve-closed (0 %) position and valve-opened (100 %) position. Contacts close when switches are actuated.		
3.2.4.1.3	Control valve operated by rotary motor with integrally mounted switch with two contacts, one actuated in valve-closed (0 %) and the other in valve-opened (100 %) position, and with torque switch. Contacts close when switches are actuated		

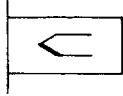
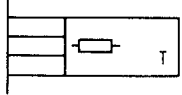
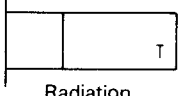
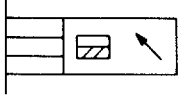
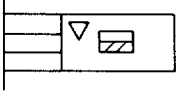
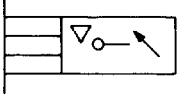
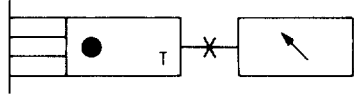
No.	Description	Use of equipment or explanation of symbol	Symbol
3.2.4.2	Control valve with diaphragm actuator, positioner, and with manual operation		
3.2.4.3	Control valve, spring-actuated to open, hand-actuated to close. Normal operating position for valve is in closed position and latched. Latch is released by a solenoid when solenoid is actuated.		
3.3	Detectors and connections for detectors		
3.3.1	Basic symbol for detectors	Ratio of sides 1 : 2. If necessary, the letter of the measuring function may be inserted in the symbol for detector (see ISO 3511/1)	
3.3.1.1	Basic symbol for nozzle or boss on line or vessel	Ratio of sides 1 : 1	
3.3.1.2	Protecting well for detectors		
3.3.1.3	Nozzle or boss with well for detector		
3.3.1.4	Insertion pipe		
3.3.1.5	Nozzle or boss with insertion pipe		
3.3.2	Detectors for flow and volumetric flow	If necessary, the letter of the measuring function may be inserted in the symbol for detector (see ISO 3511/1)	
3.3.2.1	Flow (general)		
3.3.2.2	Volumetric flow-meter (general)	This symbol must be used in conjunction with mechanical integrator, transmitter, or other functional element	
3.3.2.3	Venturi tube		
3.3.2.4	Flow nozzle		
3.3.2.5	Orifice plate		

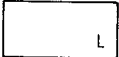
No.	Description	Use of equipment or explanation of symbol	Symbol
3.3.2.6	Variable-area meter		
3.3.2.7	Turbine meter		
3.3.2.8	Positive displacement meter		
3.3.2.9	Electromagnetic flowmeter		
3.3.3	Detectors for temperature	If necessary, the letter of the measuring function may be inserted in detector symbol (see ISO 3511/1)	
3.3.3.1	General		
3.3.3.2	Thermocouple		
3.3.3.3	Resistance element		
3.3.3.4	Liquid filled		
3.3.3.5	Gas filled		
3.3.3.6	Bi-metallic		
3.3.3.7	Glass thermometer		

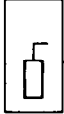
No.	Description and interpretation of the examples	Symbol
<b>3.3.4</b>	Examples of detectors for temperature	
<b>3.3.4.1</b>	Detector for skin-temperature measurement by means of thermocouple	
<b>3.3.4.2</b>	Nozzle with well and resistance element	
<b>3.3.4.3</b>	Nozzle with temperature detection by means of radiation	 <p data-bbox="1157 745 1251 768">Radiation</p>
<b>3.3.4.4</b>	Nozzle with indicating bi-metallic thermometer and well	
<b>3.3.4.5</b>	Nozzle with blind bi-metallic thermometer with switch for minimum alarm and with well	
<b>3.3.4.6</b>	Nozzle with indicating glass thermometer with switch for minimum alarm and with well	
<b>3.3.4.7</b>	Nozzle with thermometer, for example gas filled, with capillary and indicator	



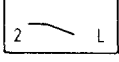
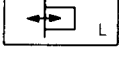
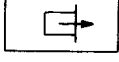
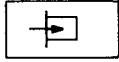
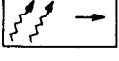
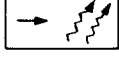
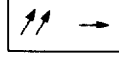
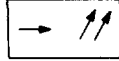
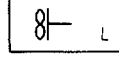
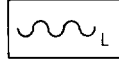
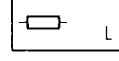

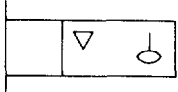
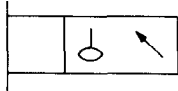
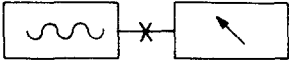
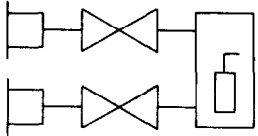
No.	Description	Use of equipment or explanation of symbol	Symbol
<b>3.3.5</b>	Detectors for level	If necessary, the letter of measured variable may be inserted in the detector symbol (see ISO 3511/1)	
<b>3.3.5.1</b>	General		
<b>3.3.5.2</b>	Float		
<b>3.3.5.3</b>	Displacer		

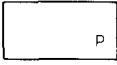
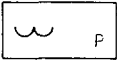
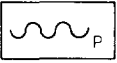
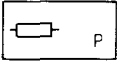
No.	Description	Use of equipment or explanation of symbol	Symbol
3.3.5.4	Electrode (capacitive)		
3.3.5.5	Electrode (conductive)	Indicate the number of electrodes per connection, (for example, 2)	
3.3.5.6	Sonic integral source and detector		
3.3.5.7	Sonic separate source and detector		
3.3.5.7.1	Source		
3.3.5.7.2	Detector		
3.3.5.8	Radioactive source and detector	Further indication as to type of radiation may be added	
3.3.5.8.1	Source		
3.3.5.8.2	Detector		
3.3.5.9	Photoelectric light source and detector		
3.3.5.9.1	Source		
3.3.5.9.2	Detector		
3.3.5.10	Propeller		
3.3.5.11	Membrane type (diaphragm)		
3.3.5.12	Resistance, for example strain gauge		

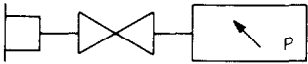
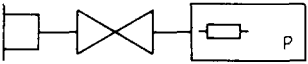
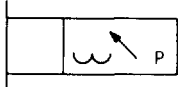

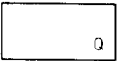

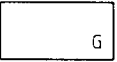



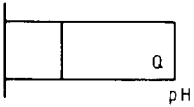
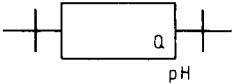
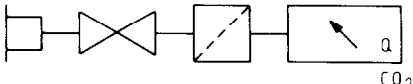
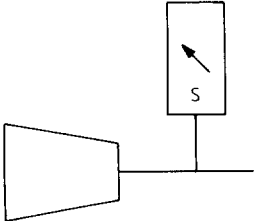

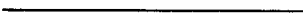
No.	Description and interpretation of the examples	Symbol
3.3.6	Examples of detectors for level	
3.3.6.1	Nozzle with float and minimum alarm (float switch)	
3.3.6.2	Nozzle with float and indicator	
3.3.6.3	Membrane with capillary and indicator	
3.3.6.4	Nozzles with valves and displacer in chamber	

No.	Description	Use of equipment or explanation of symbol	Symbol
3.3.7	Detectors for pressure	If necessary the letter of the measured variable may be inserted in the symbol for the detector (see ISO 3511/1)	
3.3.7.1	General		
3.3.7.2	Liquid-filled system bulb		
3.3.7.3	Membrane type (diaphragm)		
3.3.7.4	Pressure-sensitive strain gauge		

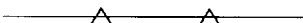

No.	Description and interpretation of the examples	Symbol
3.3.8	Examples of detectors for pressure	
3.3.8.1	Nozzle with block valve and indicating pressure gauge	
3.3.8.2	Nozzle with block valve and strain-gauge detector	
3.3.8.3	Nozzle with pressure gauge with liquid-filled system	

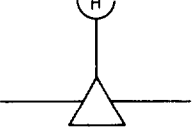
No.	Description	Use of equipment or explanation of symbol	Symbol
3.3.9	Detectors for other measured or initiating variables	See ISO 3511/1 and 3511/2, table 1 for letters indicating the required variables	
3.3.9.1	General for quality	The letter Q may be supplemented by a further indication of the measured variable	
3.3.9.2	General for nuclear radiation		
3.3.9.3	General for speed or frequency		
3.3.9.4	General for gauging, position, or length		
3.3.9.5	General for weight or force		
3.3.9.6	General for other measurement variables		

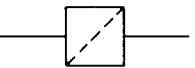
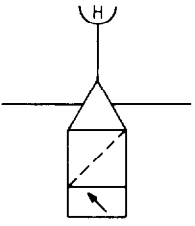
No.	Description and interpretation of the examples	Symbol
3.3.10	Examples of detectors for other measuring functions	
3.3.10.1	Nozzle with pH detector	
3.3.10.2	pH detector mounted between flanges in process line	
3.3.10.3	Nozzle with valve, filter, and CO <sub>2</sub> indicator	
3.3.10.4	Speed indicator (tachometer) on turbine shaft	

No.	Description	Use of equipment or explanation of symbol	Symbol
3.4	Lines		
3.4.1	Process lines		
3.4.2	Measuring lines		
3.4.2.1	Signal lines, general		
3.4.3		When it is necessary to distinguish between different kinds of signal lines, notes may be added or the following lines may be applied	
3.4.3.1	Electric	1) General (E) 2) Shows the number of separate electrical signal lines following the same route	  
3.4.3.2	Pneumatic (A)		
3.4.3.3	Hydraulic (L)		
3.4.3.4	Capillary		
3.4.3.5	Conducted radiation	Example: radio waves in wave guide, visible light in optical fibres	
3.5	Auxiliary devices		
3.5.1	Miscellaneous		
3.5.1.1	Reducer: differential pressure valve		
3.5.1.2	Reducer, hand-adjusted		
3.5.1.3	Differential pressure valve with external connection for reference pressure		
3.5.1.4	Filter		
3.5.1.5	Combination of hand-adjustable reducer filter and pressure indicator		

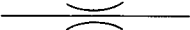

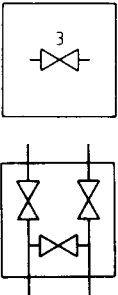
No.	Description	Use of equipment or explanation of symbol	Symbol
3.5.1.6	Condensate pot, sediment trap; capacity vessel, seal pot, etc.	Position symbol horizontally or vertically as needed	
3.5.1.7	Fixed restriction		
3.5.1.8	Adjustable restriction		
3.5.1.8	Valve manifold	Example shows a 3-valve manifold  If required, indicate internal arrangement	

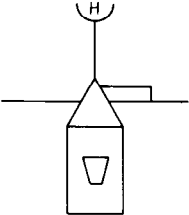
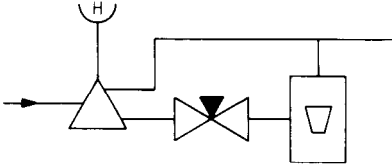
No.	Description and interpretation of the examples	Symbol
3.5.2	Examples of auxiliary devices	
3.5.2.1	Combination of hand-adjustable differential pressure valve, and variable-area flow meter.	
3.5.2.2	Combination of hand-adjustable differential pressure valve, variable-area flow meter, and needle valve	

## Annex

### Example of the use of graphical symbols

#### A.1 Flow measurement

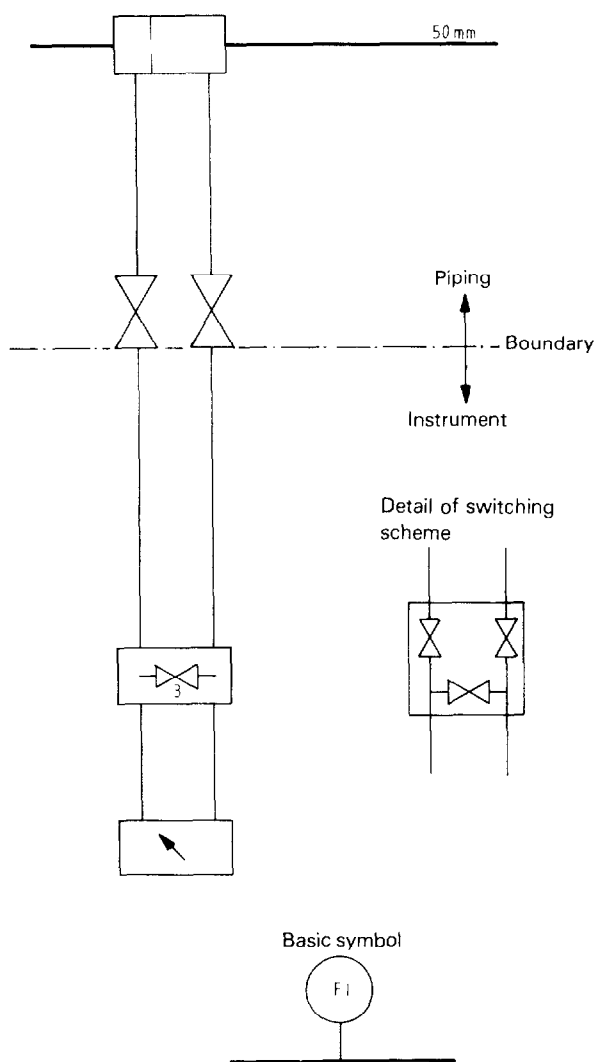

A.2 Temperature control and alarm

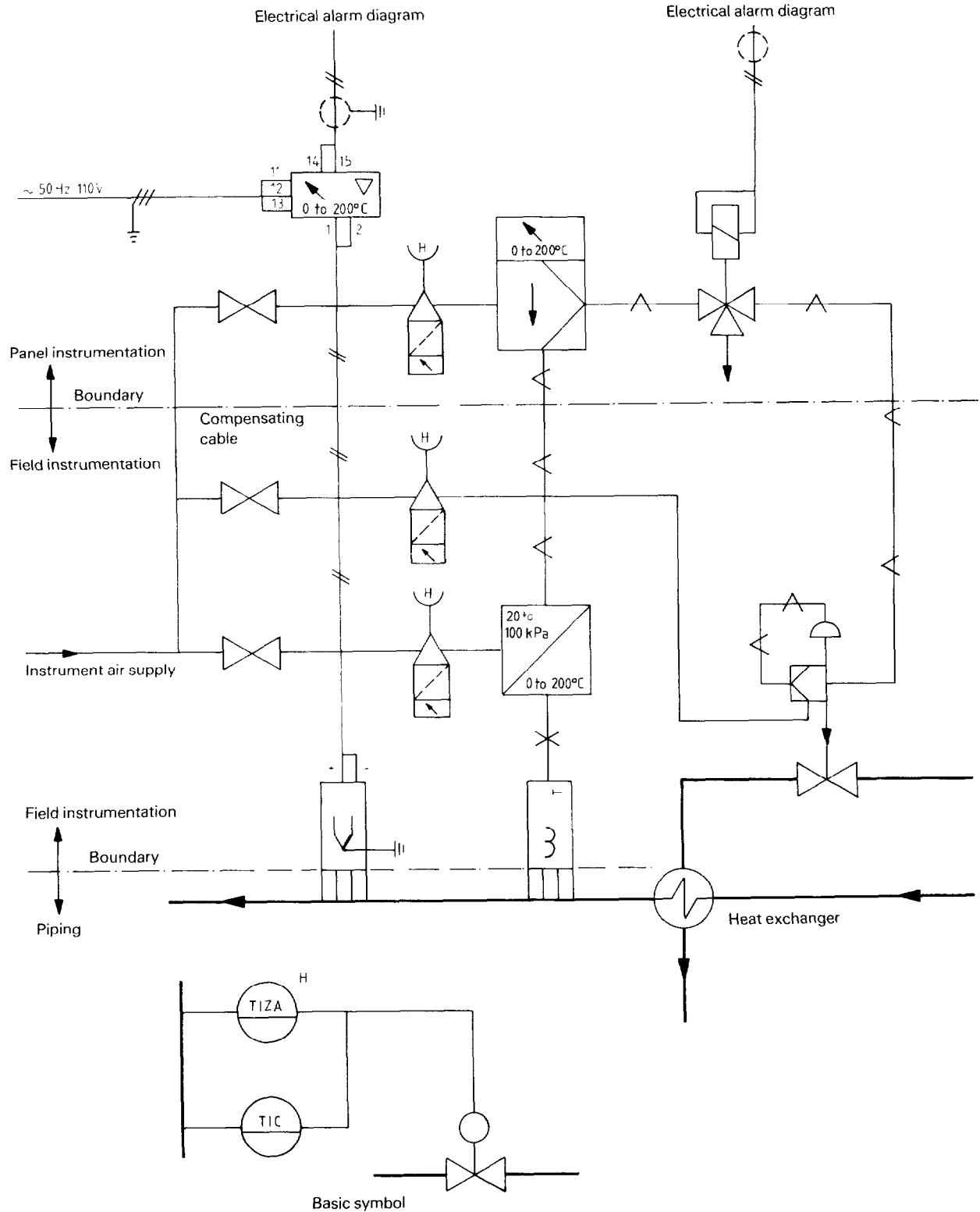

A.3 Wiring diagram

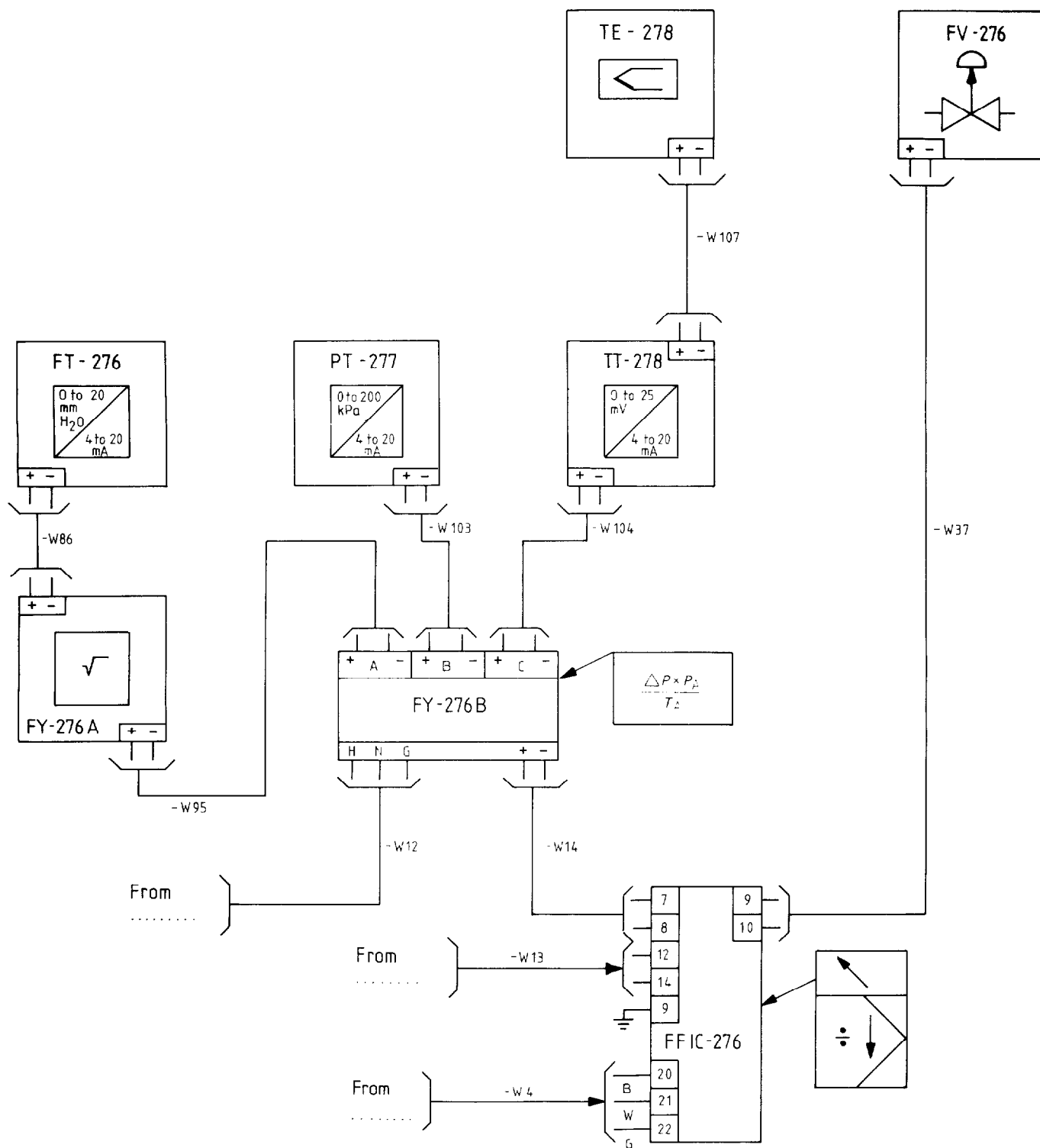

NOTE -- Symbols may be indicated outside the device symbol only if the space is limited.

A.4 Variations possible

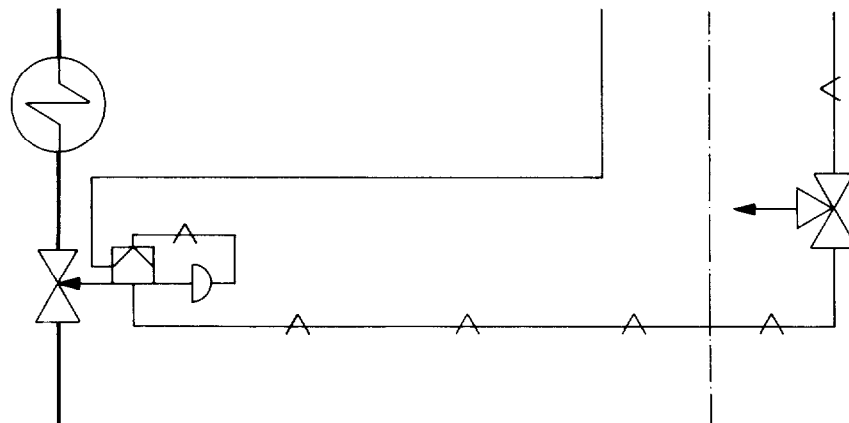

a) acceptable

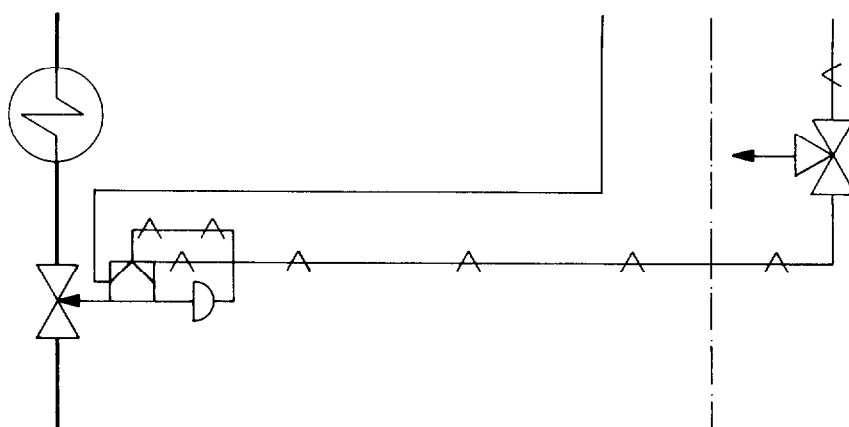

b) undesirable; crossing of lines is to be avoided if possible