

INTERNATIONAL STANDARD

ISO 3507

Second edition
1999-04-15

Laboratory glassware — Pyknometers

Verrerie de laboratoire — Pycnomètres



Reference number
ISO 3507:1999(E)

Foreword

ISO (the International Organization for Standardization) is a worldwide federation of national standards bodies (ISO member bodies). The work of preparing International Standards is normally carried out through ISO technical committees. Each member body interested in a subject for which a technical committee has been established has the right to be represented on that committee. International organizations, governmental and non-governmental, in liaison with ISO, also take part in the work. ISO collaborates closely with the International Electrotechnical Commission (IEC) on all matters of electrotechnical standardization.

International Standards are drafted in accordance with the rules given in the ISO/IEC Directives, Part 3.

International Standard ISO 3507 was prepared by Technical Committee ISO/TC 48, *Laboratory glassware and related apparatus*, Subcommittee SC 4, *Density measuring instruments*.

This second edition cancels and replaces the first edition (ISO 3507:1976) by incorporating the following changes:

- a) the title has been modified;
- b) Gay-Lussac pyknometers of 1 ml, 2 ml, 5 ml and 100 ml have been added;
- c) Reischauer pyknometers of 10 ml and 100 ml have been added;
- d) a Hubbard pyknometer of 50 ml has been added;
- e) pyknometers with ground-in thermometer and capillary side tube have been added.

© ISO 1999

All rights reserved. Unless otherwise specified, no part of this publication may be reproduced or utilized in any form or by any means, electronic or mechanical, including photocopying and microfilm, without permission in writing from the publisher.

International Organization for Standardization
Case postale 56 • CH-1211 Genève 20 • Switzerland
Internet iso@iso.ch

Printed in Switzerland

Laboratory glassware — Pyknometers

1 Scope

This International Standard specifies requirements for a series of pyknometers for general laboratory use for the determination of the densities of liquids.

Specialized pyknometers for use with particular products, or otherwise not in common use, are excluded. Sufficient details to define such pyknometers should be included in International Standards which specify or describe their use.

A device suitable for adjustment of the liquid level in the neck of the Reischauer pyknometer is shown in annex A.

2 Normative references

The following normative documents contain provisions which, through reference in this text, constitute provisions of this International Standard. For dated references, subsequent amendments to, or revisions of, any of these publications do not apply. However, parties to agreements based on this International Standard are encouraged to investigate the possibility of applying the most recent editions of the normative documents indicated below. For undated references, the latest edition of the normative document referred to applies. Members of ISO and IEC maintain registers of currently valid International Standards.

ISO 383, *Laboratory glassware — Interchangeable conical ground joints.*

ISO 384:1978, *Laboratory glassware — Principles of design and construction of volumetric glassware.*

ISO 386, *Liquid-in-glass laboratory thermometers — Principles of design, construction and use.*

ISO 719, *Glass — Hydrolytic resistance of glass grains at 98 °C — Method of test and classification.*

ISO 3585, *Borosilicate glass 3.3 — Properties.*

3 Basis of adjustment

3.1 Unit of volume

The unit of volume shall be the millilitre (ml), which is equivalent to the cubic centimetre (cm³).

NOTE The term millilitre (ml) is commonly used as a special name for the cubic centimetre (cm³), in accordance with a decision of the Twelfth Conférence Générale des Poids et Mesures. The term millilitre is acceptable, in general, for references in International Standards to capacities of volumetric glassware and it is used in this International Standard.

3.2 Reference temperature

If the actual capacity is marked on a pycnometer, the verification temperature at which this actual capacity is determined shall also be marked. Under normal circumstances the standard reference temperature shall be 20 °C.

When it is necessary in tropical countries to work at an ambient temperature considerably above 20 °C, and these countries do not wish to use the standard reference temperature of 20 °C, a temperature of 27 °C is recommended.

4 Types and series of sizes

Two types of pycnometer tube and four types of pycnometer flask are specified, as listed in Table 1 and illustrated in Figures 1 to 6. Types 1 and 2, of tubular form, are for suspension; types 3, 4, 5 and 6, of flask form, are free-standing on flat bases.

Types 1, 3 and 4, and type 2 if provided with caps, shall be used for volatile liquids. Type 5 shall be used for very viscous materials.

The series of sizes for each type of pycnometer shall be as shown in Table 1.

Table 1 — Types and sizes of pycnometers

Type	Designation	Nominal capacities	
		ml	
1	Lipkin	1 2 5 10	
2	Sprengel	5 10 25	
3	Gay-Lussac	1 2 5 10 25 50 100	
4	Reischauer	10 25 50 100	
5	Hubbard	25 50	
6	Ground-in thermometer	10 25 50 100	

5 Capacities of pycnometers

5.1 Actual capacity

The actual capacity is the volume, in millilitres, of water at the reference temperature contained by the pycnometer, which is also at that temperature. The volume, according to type, is defined as follows.

- Type 1: Between zero lines of the two scales;
- Type 2: From tip of jet to graduation line;
- Type 3 and 5: To top of bore of stopper;
- Type 4: To zero line of scale;
- Type 6: To top of capillary side tube.

The recommended reference temperature is 20 °C but other appropriate temperatures may be selected in accordance with 3.2.

5.2 Nominal capacity

The nominal capacity is the actual capacity rounded to the nearest appropriate value given in Table 1.

6 Difference between actual capacity, nominal capacity and accuracy

The difference between the actual capacity and the nominal capacity of a pycnometer shall not exceed the appropriate maximum value shown in Table 2, 3 or 4.

The actual capacity of a pycnometer shall be determined at the 95 % confidence level ($k = 2$) with an uncertainty of measurement which does not exceed the following values:

Type 1	Lipkin	$\pm 5 \mu\text{l}$
Type 2	Sprengel	$\pm 5 \mu\text{l}$
Type 3	Gay-Lussac	$\pm 10 \mu\text{l}$
Type 4	Reischauer	$\pm 5 \mu\text{l}$
Type 5	Hubbard	$\pm 50 \mu\text{l}$
Type 6	Ground-in thermometer	$\pm 15 \mu\text{l}$

7 Construction

7.1 Material

Pycnometers shall be made from glass of hydrolytic class not lower than HGB3 according to ISO 719, with a coefficient of thermal expansion not exceeding $3,3 \times 10^{-6} \text{ }^\circ\text{C}^{-1}$.

NOTE This includes borosilicate glass 3.3 according to ISO 3585.

Pycnometers shall be as free as possible from visible defects and reasonably free from internal strain. Stoppers or taps shall be made from glass having similar thermal properties to that used for the pycnometers to which they are fitted.

7.2 Mass

The mass of a pycnometer shall not exceed the appropriate maximum value shown in Tables 2, 3 and 4.

7.3 Dimensions

Pycnometers shall comply with the appropriate toleranced dimensional requirements shown in Tables 2, 3 and 4. The additional dimensions which are specified by nominal values without tolerances are for the guidance of manufacturers.

7.4 Shape

7.4.1 The shapes of the six types of pycnometer shall be generally as shown in Figures 1 to 6 and shall comply with the detailed requirements given in 7.4.2 to 7.4.8.

All tapered portions of pycnometers shall be smoothly formed so as to avoid sharp shoulders which could entrap air bubbles.

7.4.2 Pyknometers of type 1 shall have an oval bulb, as illustrated in Figure 1, which merges gradually into the tubes at each end.

The left arm of the pyknometer shall be bent as shown in Figure 1, the distance from the end to the outside of the bend being (20 ± 2) mm and the included angle being 50° to 55° .

The two ends of the pyknometer shall be finished square with the axis of the tubes and smoothly fire-polished without constriction.

7.4.3 Pyknometers of type 2 shall have a cylindrical bulb with tapered ends which merge gradually into the adjoining tubes.

The two arms shall be bent at an angle of approximately 75° to the vertical and shall lie in the same plane as the U-portion of the pyknometer. One arm shall be drawn down to a smooth tapered jet, the end of which shall have a bore of approximately 0,5 mm and shall be ground smooth at right angles to the axis of the tube and slightly bevelled on the outside.

The end of the other arm of the pyknometer shall be finished square with the axis of the tube and smoothly firepolished without constriction.

7.4.4 Pyknometers of type 2 that are fitted with ground-on caps at the ends of the side arms shall comply with the following additional requirements.

- a) The ground zones of the joints shall be such that the two caps are interchangeable, and the joints comply with the requirements for size 5/9 of ISO 383.
- b) The cones of the joints shall be formed with a minimum distortion of the bore of the tube, and such distortion shall be smoothly tapered. The tip of the jet shall project beyond the small end of the ground zone and
- c) The caps shall be smoothly ground to a good fit on the cones and shall be of sufficient size to clear the tip of the jet.

7.4.5 Pyknometers of types 3, 4, 5 and 6 shall stand vertically without rocking or spinning when placed on a level surface. They shall not topple when placed empty, with the stopper inserted, on a surface inclined at an angle of 15° to the horizontal.

7.4.6 Pyknometers of types 3, 4 and 6 shall have a body shape similar to that shown in Figures 3, 4 and 6, in which the plane of maximum diameter is at approximately one-third of the distance from the base to the bottom of the neck.

7.4.7 Pyknometers of type 5 shall have a body shape as shown in Figure 5, in which the upper end of the conical portion merges smoothly with the neck without a sharp shoulder. The radius of curvature between the lower end of the conical portion and the base shall not be less than 5 mm.

7.4.8 Pyknometers of type 6 shall have a capillary side tube smoothly fitted to the body at an angle of approximately 90° . The upper part of the capillary side tube shall be positioned parallel to the vertical axis of the pyknometer body. The outer diameter of the capillary side tube shall be approximately 6 mm and the upper end shall be ground to a flat surface of approximately 6 mm.

7.5 Necks

7.5.1 For types 3 and 5, the top of the neck of the flask shall be reconstructed so that there is no channel in which liquid can lodge between the stopper and the neck of the bottle. The outer edge of the top of the neck shall be slightly bevelled.

The ground zone of the neck shall extend below the bottom of the stopper when the latter is in position and there shall be no ridge at the lower end of the grinding.

NOTE This can be a manufactured tool process or a grinding process.

7.5.2 For type 4, the portion of the neck bearing the graduated scale shall be cylindrical and the internal diameter shall be uniform over the entire scale length. The internal diameter of the neck above this portion shall not be constricted. The upper end of the neck shall be ground either as a socket with a strengthening bead above as shown in Figure 4, or as a cone. In either case the grinding shall comply with the requirements of ISO 383, for the joint sizes listed in Table 3.

7.5.3 For type 6, the neck intended to take up the thermometer shall be ground to a socket complying with ISO 383, size 10/19. There shall be no channel between the ground socket and the fitted thermometer in which liquid can lodge.

The upper end of the capillary side tube shall be ground as a cone complying to ISO 383, size 7/16, enabling a capping of the side tube.

7.6 Stoppers and thermometer

7.6.1 Stoppers for pycnometer flasks shall be fine ground to fit the necks of the flasks liquid-tight and shall comply with the requirements given in 7.6.2 to 7.6.6.

7.6.2 For type 3, the ground zone of the stopper shall extend above the neck of the flasks when the stopper is in position in the flask and this portion shall also be finely ground.

The top of the stopper shall be ground at right angles to the axis and polished, and shall have a slightly bevelled edge.

The bottom of the stopper shall be fine ground at right angles to the axis and shall have a slightly bevelled edge.

The edge where the hole through the stopper intersects the top and bottom of the stopper shall be regular in outline and not chipped or countersunk.

The upper portion of the stopper shall have two inclined polished faces on opposite sides. These inclined faces shall not encroach on the ground zone of the stopper.

7.6.3 For type 4, the stopper or cap shall be smoothly ground to a good fit in or on the neck of the flask, in accordance with interchangeable requirements, as indicated in 7.5.2.

7.6.4 For type 5, the stopper shall comply with the requirements of the first, third and fourth paragraphs of 7.6.2. The underside of the stopper shall be smoothly ground to a concave shape forming part of a sphere, the resulting edges being cleanly formed without chipping.

7.6.5 For type 6 and, if applicable, for type 2, the cap for the side tube shall be provided with a ground socket complying with ISO 383, joint size 7/16.

7.6.6 Pycnometers of type 6 shall be supplied with enclosed-scale thermometers complying with the requirements of ISO 386 and with a ground cone complying with size 10/19 of ISO 383. The temperature measuring range shall be 10 °C to 35 °C, with a scale division of 0,2 °C and a maximum permitted error not exceeding 0,2 °C. The thermometric liquid shall be mercury. The thermometer length is specified in Table 4.

Where the use of mercury thermometers is not permitted, alternative thermometers of at least the same precision shall be used.

8 Graduation lines

8.1 General

8.1.1 Graduation lines shall be clean, permanent, uniform lines of thickness not exceeding 0,3 mm.

8.1.2 All graduation lines shall lie in planes at right angles to the axis of the tube on which they are situated.

8.1.3 Adjustment and reading of the meniscus of liquids shall be performed according to clause 5 in ISO 384:1978.

8.2 Type 1

8.2.1 Position of scale

Each vertical arm of the pycnometer shall have a graduated scale of length 8 cm, divided into millimetres. The two scales shall be on the same level when the pycnometer is in a vertical position. Dimensions limiting the position of the scale are given in Table 2.

8.2.2 Length of graduation lines

8.2.2.1 The long lines representing each centimetre shall either extend completely round the circumference of the tube or leave a gap not exceeding 10 % of the circumference.

8.2.2.2 The length of the medium lines midway between the long lines shall be at least one-quarter of the circumference of the tube.

8.2.2.3 There shall be four short lines between consecutive long and medium lines, each of length at least one-eighth of the circumference of the tube.

8.2.2.4 The short and medium lines shall appear centrally down the front of the two tubes when the pycnometer is viewed in a vertical position with the bent arm to the left.

8.2.3 Figuring of graduation lines

The two scales shall be numbered with figures representing centimetres from 0 at the lowest long line to 8 at the top.

The figures shall be placed immediately above the long lines to which they refer, and slightly to the side of the shorter lines, as indicated in Figure 1.

8.3 Type 2

The pycnometer shall have a single graduation line completely encircling the arm which is not provided with a jet. This line shall be placed not less than 5 mm from the point where the tube begins to bend and not less than 20 mm from the open end of the tube.

8.4 Type 4

8.4.1 The neck of the pycnometer shall have a ring mark of thickness not exceeding 0,3 mm. The neck of the pycnometer should have, in addition, a graduated scale of length 2 cm divided into millimetres. There shall be at least 5 mm of the tube of uniform bore above and below the ring mark or the graduated scale before the tube starts to expand.

8.4.2 The length and sequence of graduation lines shall comply with the requirements of 8.2.2.1 to 8.2.2.3. The placing of the lines shall be as indicated in Figure 4.

8.4.3 The long lines of the scale shall be numbered with figures representing millimetres, with 0 at the bottom, 10 in the centre and 20 at the top.

9 Marking

The following shall be permanently marked on all pycnometers.

NOTE The permanence of marking can be assessed by the test methods specified in ISO 4797.¹⁾

¹⁾ ISO 4794, *Laboratory glassware — Methods for assessing the chemical resistance of enamels used for colour coding and colour marking.*

- a) The symbol "≈" to indicate that the capacity is approximate and not accurately adjusted, followed by a number to indicate the nominal capacity.
- b) The symbol "ml" or the symbol "cm³" to indicate the unit of volume.
- c) As an alternative to inscriptions a) and b), or in addition to them, a figure showing determined capacity to the nearest 0,001 ml together with the temperature at which this determined capacity applies.

EXAMPLE: 49,813 ml at 20 °C (see 3.2).

- d) The abbreviation "ln" and "20 °C" to indicate that the pycnometer is intended to contain its nominal capacity at 20 °C.
- e) The maker's or vendor's name or mark.
- f) For types 3, 5 and 6, an identification number, which shall be repeated on the stopper or the thermometer. Identification numbers may also be marked on other types of pycnometer and their caps or stoppers.
- g) For types 3, 5 and 6, the neck and the stopper or the thermometer shall be marked with a short vertical line or mark to enable a unique positioning of the stopper or thermometer in the neck.

10 Visibility of graduation lines, figures and markings

10.1 All figures and inscriptions shall be of such size and form as to be clearly legible under normal conditions of use.

10.2 All graduation lines, figures and inscriptions shall be clearly visible and permanent under normal conditions of use. Any filling which is used to improve visibility shall be sufficiently durable to prevent any significant loss in mass during use.

Table 2 — Dimensional requirements for pycnometer tubes types 1 and 2 (see 7.3)

Characteristic	Type 1 (Lipkin) (see Figure 1)				Type 2 (Sprengel) (see Figure 2)		
	1	2	5	10	5	10	25
Nominal capacity, ml	1	2	5	10	5	10	25
Difference between actual capacity and nominal capacity, max., ml	± 0,2	± 0,3	± 0,5	± 1	± 0,5	± 1	± 2
Maximum mass (including cap for type 2, if fitted), g	30				25	30	40
Overall height, A, mm	175 ± 5				90	105	120
Height above scale, B, min., mm	40				—	—	—
Height from bulb to scale, C, min., mm	5				—	—	—
Distance between centres of vertical limbs, D, mm	28 ± 2				10	13	16
Length of side arms, E, mm	—				40	45	50
External diameter of tubing, F, mm	6				6		
Internal diameter of tubing, G, mm	1 ± 0,1				1,5		
Length from bottom of bulb to zero graduation line, H, mm	40				—	—	—
Length of bulb, H, mm	—				60	75	90
External diameter of bulb, J, mm	11	14	20	25	12	17	22

Table 3 — Dimensional requirements for pycnometer flasks types 4 and 5 (see 7.3)

Characteristic	Type 4 (Reischauer) (see Figure 4)				Type 5 (Hubbard) (see Figure 5)	
	10	25	50	100	25	50
Nominal capacity, ml	10	25	50	100	25	50
Difference between actual capacity and nominal capacity, max., ml	± 1	± 2	± 3	± 3	± 2	± 3
Maximum mass including stopper, g	20	25	30	50	40	60
Height to top of neck, A^a , mm ≈	110	120	135	150	45	63
Diameter of body, B^a , mm ≈	33	40	50	60	40	45
Diameter of base, C^a , mm ≈	23	27	35	40	28	29
Height of stopper, E^a , mm ≈	—				26	
External diameter of neck, F , mm ≈	8				—	—
Bore of stopper, G , mm ≈	—				2	
Internal diameter of neck, G , mm	2,2 to 3,1				—	—
Depth of concavity in stopper, K , mm ≈	—				2,3	
Neck socket grinding ^{b)}	7/11 or 7/16				24/10 or 24/12	
<p>a) These dimensions are appropriate to the preferred shapes of pycnometers illustrated in Figures 3 to 5 but will vary if other suitable patterns are used.</p> <p>b) In accordance with ISO 383.</p>						

Table 4 — Dimensional requirements for pycnometer flasks types 3 and 6 (see 7.3)

Characteristic	Type 3 (Gay-Lussac) (see Figure 3)							Type 6 (Ground-in thermometer) (see Figure 6)			
	1	2	5	10	25	50	100	10	25	50	100
Nominal capacity, ml	1	2	5	10	25	50	100	10	25	50	100
Difference between actual capacity and nominal capacity, max., ml	± 0,1	± 0,3	± 0,5	± 1	± 2	± 3	± 3	± 1	± 2	± 3	± 3
Maximum mass including stopper, g	10	15	20	25	30	35	55	25	30	45	60
Height to top of neck, A ^{a)} , mm ≈	30	35	45	50	60	75	90	52	60	72	90
Diameter of body, B ^{a)} , mm ≈	15	18	22	27	37	47	57	27	37	47	57
Diameter of base, C ^{a)} , mm ≈	15	16	18	22	30	36	42	22	30	36	42
Height of stopper, E ^{a)} , mm ≈	—							6			
External diameter of neck, F ^{a)} , mm ≈	45							—			
Bore of stopper, G, mm	1 ± 0,3							—			
Internal diameter of neck (side tube), G ^{a)} , mm	—							1,5	1,7		
Top end diameter of neck grinding, mm	7,5 ± 1		10 ± 1								
Minimum length of engagement of stopper in neck ^{b)} , mm ≈	11		13								
Neck socket grinding ^{c)} (for thermometer)	—							10/19			
Neck cone grinding ^{c)} (side tube)	—							7/16			
Total length of thermometer, mm ≈	—							135	145	155	170
<p>a) These dimensions are appropriate to the preferred shapes of pycnometers illustrated in Figures 3 to 5 but will vary if other suitable patterns are used.</p> <p>b) Interchangeable grinding is not suitable for the neck and stopper of type 3.</p> <p>c) In accordance with ISO 383.</p>											

Dimensions in millimetres

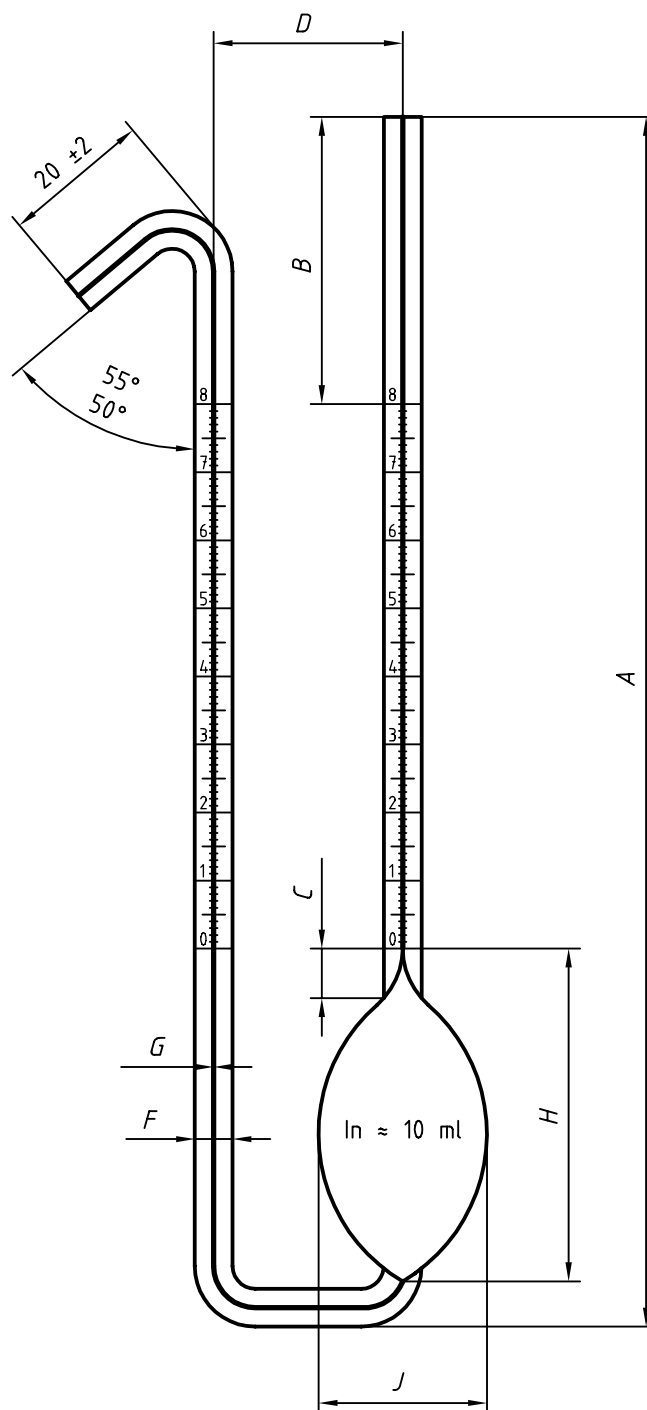

NOTE See Table 2 for definitions of symbols.

Figure 1 — Type 1 (Lipkin) pycnometer tube

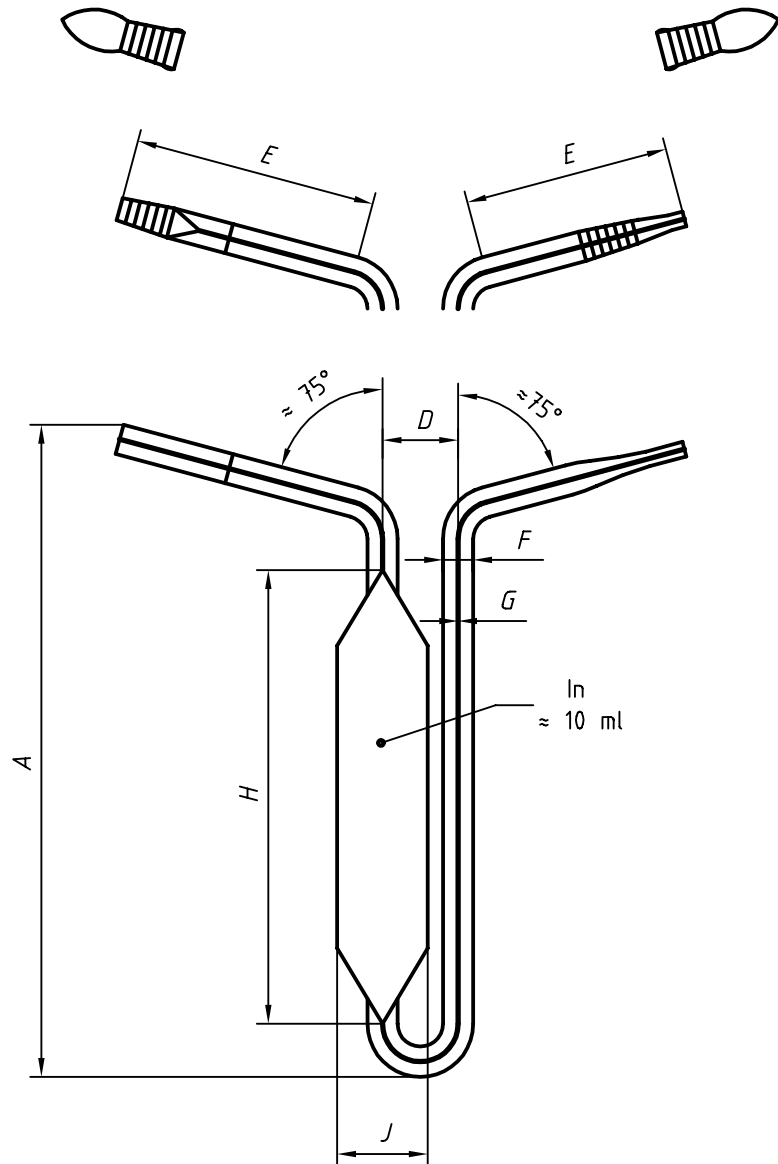

NOTE See Table 2 for definitions of symbols.

Figure 2 — Type 2 (Sprengel) pyknometer tube

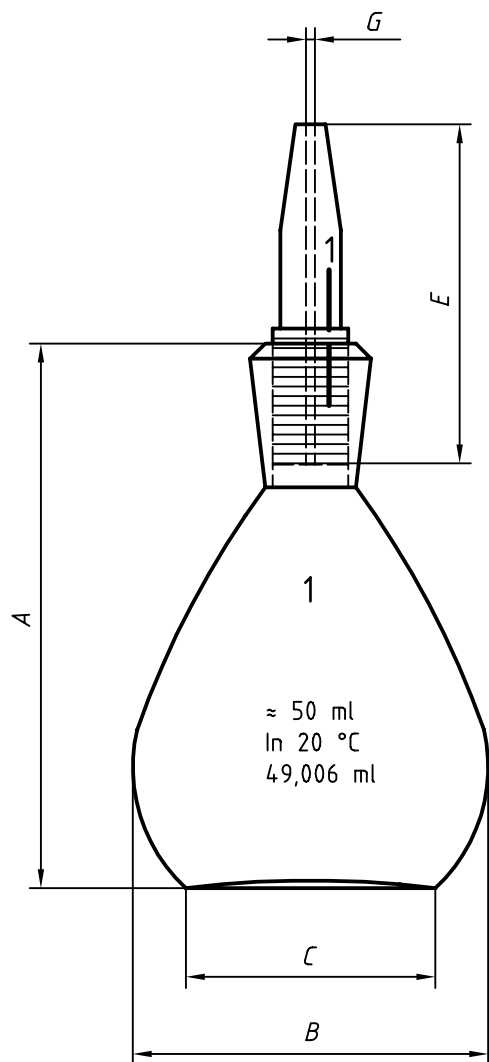

NOTE See Table 4 for definitions of symbols.

Figure 3 — Type 3 (Gay-Lussac) pycnometer flask

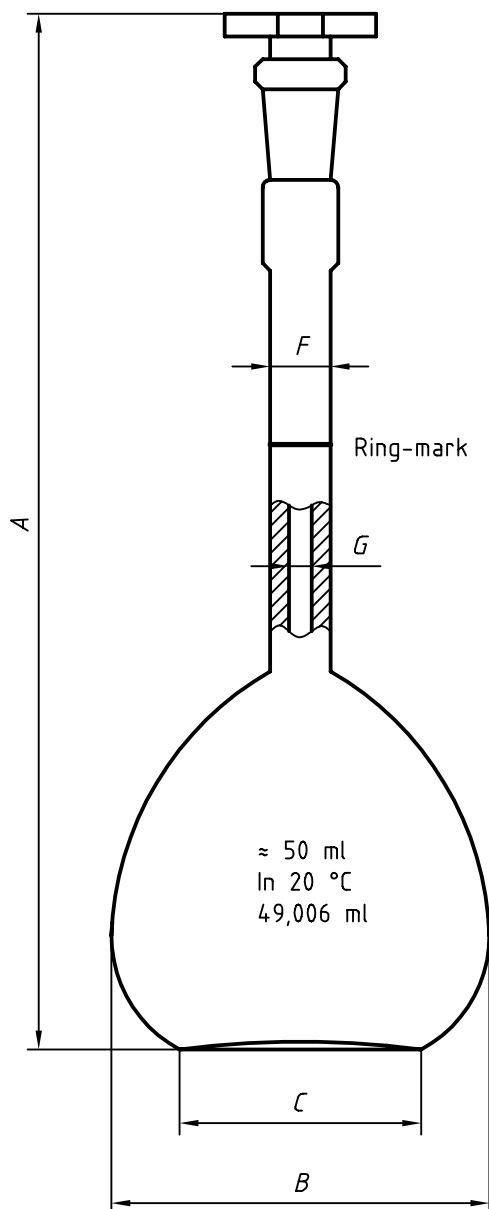

NOTE See Table 3 for definitions of symbols.

Figure 4 — Type 4 (Reischauer) pycnometer flask

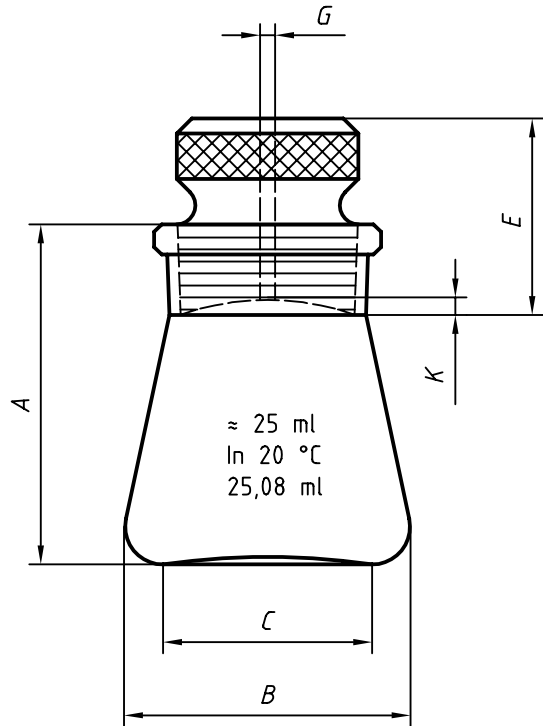

NOTE See Table 3 for definitions of symbols.

Figure 5 — Type 5 (Hubbard) pycnometer flask

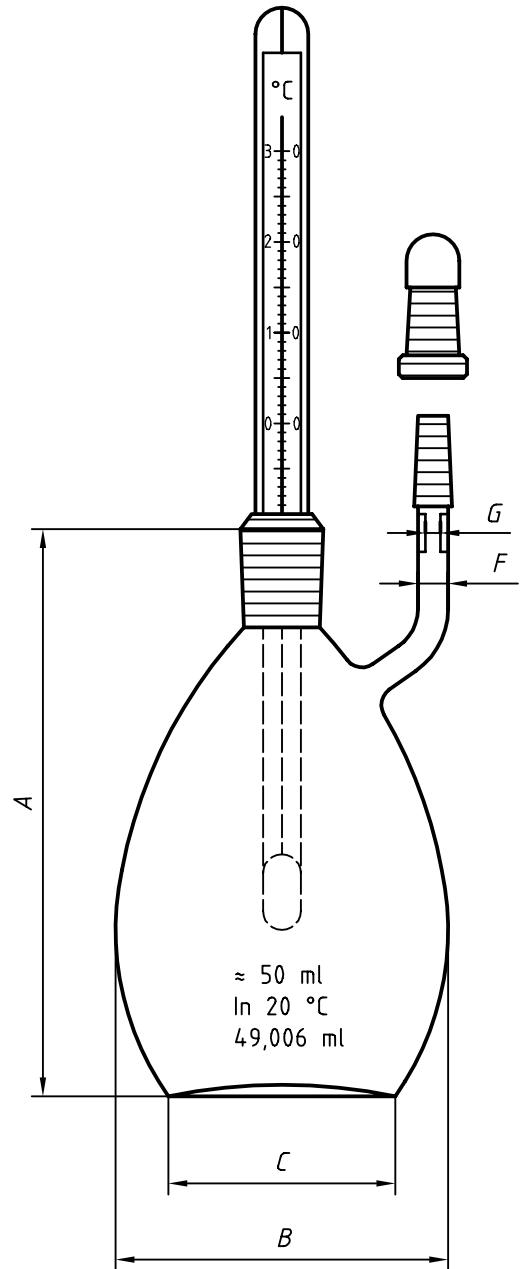

NOTE See Table 4 for definitions of symbols.

Figure 6 — Pycnometer flask with ground-in thermometer and capillary side tube

Annex A
(informative)

Device for adjusting the liquid level in a Reischauer-type pycnometer

See Figures A.1 and A.2.

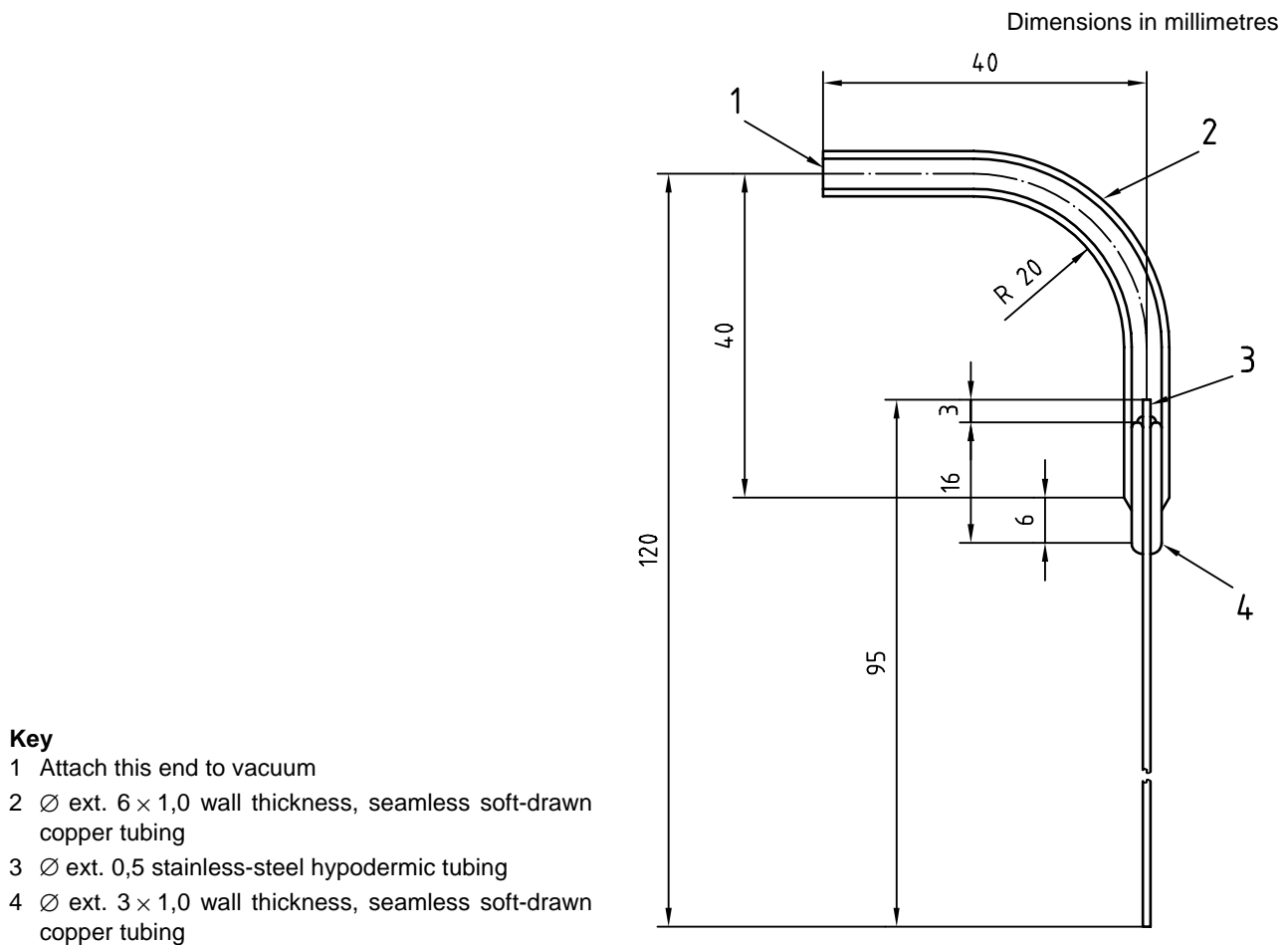

Figure A.1 — Draw-off needle

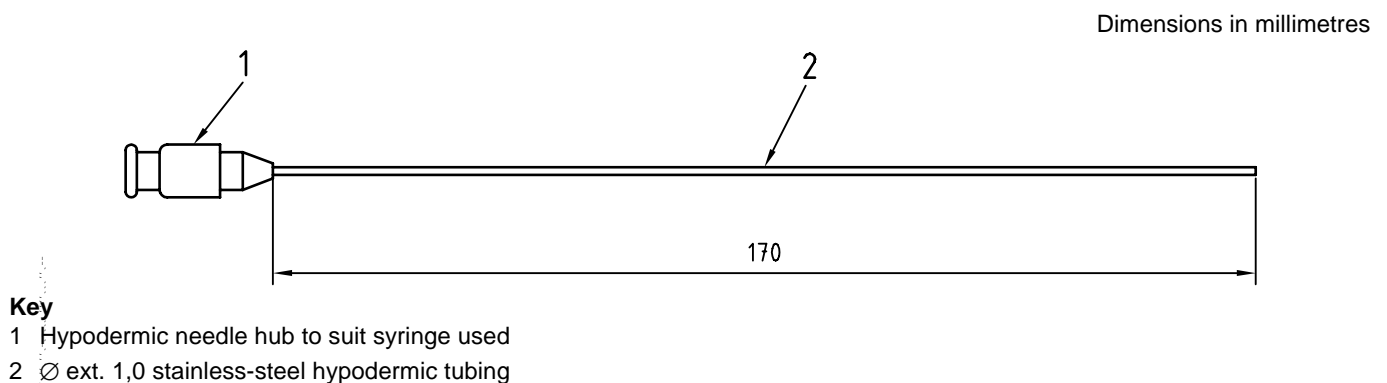

Figure A.2 — Filling needle

ICS 17.060

Price based on 14 pages
