

INTERNATIONAL STANDARD**3503**

INTERNATIONAL ORGANIZATION FOR STANDARDIZATION • МЕЖДУНАРОДНАЯ ОРГАНИЗАЦИЯ ПО СТАНДАРТИЗАЦИИ • ORGANISATION INTERNATIONALE DE NORMALISATION

Assembled joints between fittings and polyethylene (PE) pressure pipes — Test of leakproofness under internal pressure when subjected to bending

Assemblages entre raccords et tubes sous pression en polyéthylène (PE) — Essai d'étanchéité à la pression intérieure lorsqu'ils sont soumis à une courbure

First edition — 1976-06-01

UDC 621.643.29 : 678.742.2 : 620.162.4

Ref. No. ISO 3503-1976 (E)

Descriptors : plastic pipes, polyethylene, pressure pipes, pipe fittings, pipe joints, tests, high pressure tests.

Price based on 2 pages

ISO 3503-1976 (E)

FOREWORD

ISO (the International Organization for Standardization) is a worldwide federation of national standards institutes (ISO Member Bodies). The work of developing International Standards is carried out through ISO Technical Committees. Every Member Body interested in a subject for which a Technical Committee has been set up has the right to be represented on that Committee. International organizations, governmental and non-governmental, in liaison with ISO, also take part in the work.

Draft International Standards adopted by the Technical Committees are circulated to the Member Bodies for approval before their acceptance as International Standards by the ISO Council.

International Standard ISO 3503 was drawn up by Technical Committee ISO/TC 138, *Plastics pipes, fittings and valves for the transport of fluids*, and circulated to the Member Bodies in June 1974.

It has been approved by the Member Bodies of the following countries :

Australia	Ireland	South Africa, Rep. of
Austria	Israel	Spain
Belgium	Italy	Sweden
Chile	Mexico	Switzerland
Czechoslovakia	Netherlands	Turkey
Denmark	Norway	U.S.A.
Finland	Poland	U.S.S.R.
Germany	Portugal	Yugoslavia
India	Romania	

The Member Bodies of the following countries expressed disapproval of the document on technical grounds :

France
United Kingdom

© International Organization for Standardization, 1976 •

Printed in Switzerland

Assembled joints between fittings and polyethylene (PE) pressure pipes — Test of leakproofness under internal pressure when subjected to bending

1 SCOPE AND FIELD OF APPLICATION

This International Standard specifies a method for checking the leakproofness under internal pressure of assembled joints (excluding fusion-welded joints) between mechanical fittings and polyethylene (PE) pressure pipes when subjected to bending. It defines the calculation methods for the average bending radius and how to perform this bending.

Checking of the leakproofness under internal pressure is carried out in accordance with the method given in ISO 3458, and applies to pipes with a nominal diameter up to and including 63 mm (2.480 in).

2 REFERENCE

ISO 3458, *Assembled joints between fittings and polyethylene (PE) pressure pipes — Test of leakproofness under internal pressure.*

3 PRINCIPLE

Checking the leakproofness of joints of an assembly with one pipe and two connected end fittings, to which bending is applied according to its free length L .

This bending has an average radius calculated from the pipe nominal diameter and pressure:

4 APPARATUS

(A suitable apparatus is shown in the figure.)

4.1 Bending-gauge having a bearing length (l) equal to three-quarters of the free length between fittings, i.e. equal to 7,5 times the pipe nominal outside diameter.

This bearing length (l) shall have a bending radius equal to that specified for the pipe under test, as follows :

- 15 times the nominal outside diameter for pipe with nominal pressure 1 MPa (10 bar) or less;
- 20 times the nominal outside diameter for pipe with nominal pressure more than 1 MPa (10 bar).

4.2 Pressurizing system in accordance with the specification given in ISO 3458.

5 TEST SPECIMEN

The specimen shall consist of a polyethylene pipe of type and size conforming to the fittings to be tested. Its length shall be such that its free length (L) between the fittings is 10 times the pipe nominal outside diameter.

The assembly of the joints should be carried out in accordance with the individual national practices or standards and in such a way as to meet the requirements of ISO 3458.

6 PROCEDURE

The test shall be carried out at a temperature of 20 ± 2 °C with an average bending radius (R) of :

- 15 times the pipe nominal outside diameter, if its nominal pressure is equal to 1 MPa (10 bar) or less;
- 20 times this nominal outside diameter, with nominal pressure more than 1 MPa (10 bar).

After assembly, the pipe length shall be such that the free length between fittings is equal to 10 times its nominal diameter.

Set up the test specimens on the bending-gauge in such a way that :

- bending stresses are supported by fittings;
- pipe is applied to the bending-gauge's entire length, so that, at either end of it, two free pipe sections equal in length are available, about 1/8 of the free length each;
- hydrostatic pressure is applied to the mounting according to the specifications of ISO 3458. In addition the test shall be continued by increasing pressure until the pipe bursts.

The test specimen shall be free from leaks for at least 1 h under internal pressure equal to three times the nominal pressure, in accordance with the specifications of ISO 3458.

7 TEST REPORT

The test report shall include the following particulars :

- a) a reference to this International Standard;
- b) whether or not the fitting has failed during the test period and under what conditions;
 - if the assembly fails to meet the pressure test for

1 h in accordance with ISO 3458, indicate whether the joint leaked or the pipe burst, and at which pressure;

- c) details of variations in procedure not specified in this International Standard, as well as external conditions likely to have affected the results.

The joint shall be deemed satisfactory if no failure has been observed during the test period.

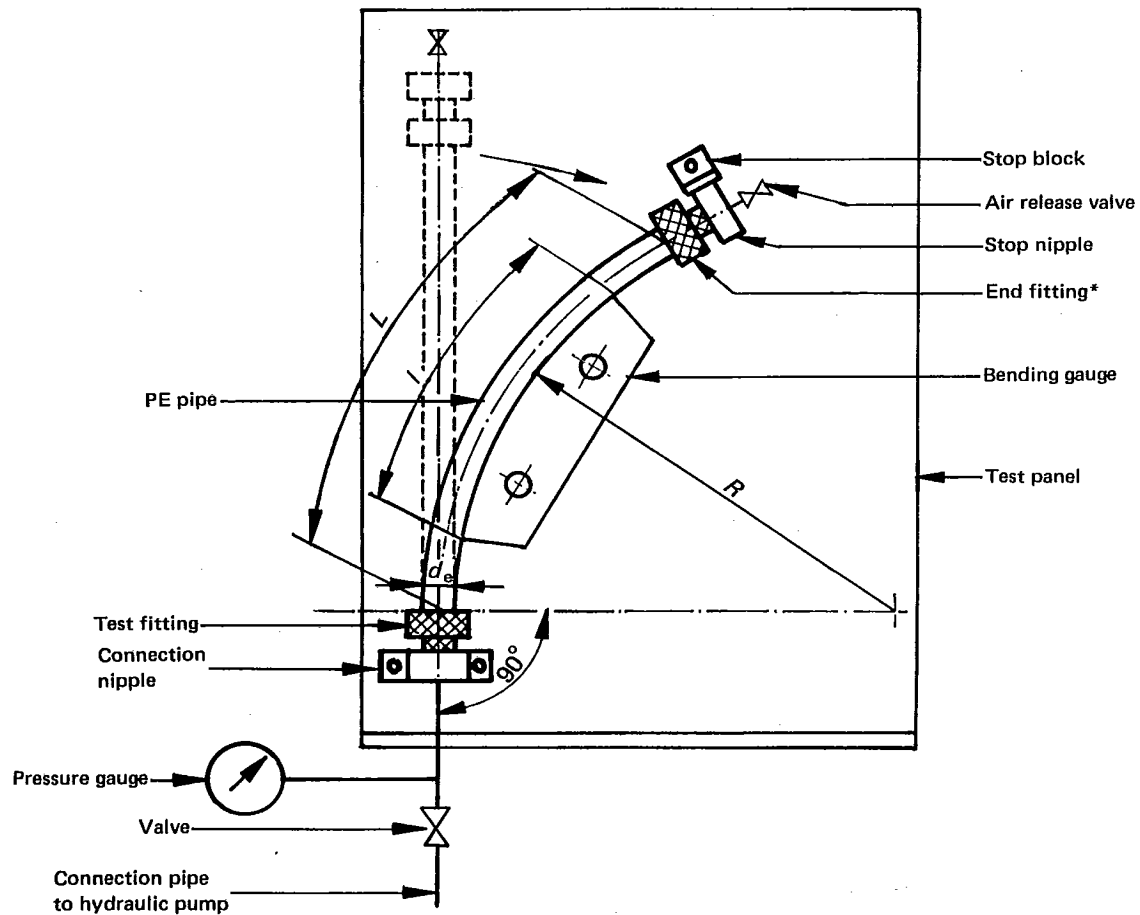

* The end fitting is only used for closing the test specimen.

FIGURE -- Diagram of suitable apparatus