**Non-destructive testing — Penetrant
testing —**

**Part 3:
Reference test blocks**

*Essais non destructifs — Examen par ressuage —
Partie 3: Pièces de référence*



Reference number
ISO 3452-3:2013(E)



COPYRIGHT PROTECTED DOCUMENT

© ISO 2013

All rights reserved. Unless otherwise specified, no part of this publication may be reproduced or utilized otherwise in any form or by any means, electronic or mechanical, including photocopying, or posting on the internet or an intranet, without prior written permission. Permission can be requested from either ISO at the address below or ISO's member body in the country of the requester.

ISO copyright office
Case postale 56 • CH-1211 Geneva 20
Tel. + 41 22 749 01 11
Fax + 41 22 749 09 47
E-mail copyright@iso.org
Web www.iso.org

Published in Switzerland

Contents

	Page
Foreword	iv
1 Scope	1
2 Normative references	1
3 Description of reference blocks	1
4 Type 1 reference block design and dimensions	1
5 Type 2 reference block design and dimensions	2
5.1 Design	2
5.2 Measurement	5
6 Identification	5
Bibliography	6

Foreword

ISO (the International Organization for Standardization) is a worldwide federation of national standards bodies (ISO member bodies). The work of preparing International Standards is normally carried out through ISO technical committees. Each member body interested in a subject for which a technical committee has been established has the right to be represented on that committee. International organizations, governmental and non-governmental, in liaison with ISO, also take part in the work. ISO collaborates closely with the International Electrotechnical Commission (IEC) on all matters of electrotechnical standardization.

The procedures used to develop this document and those intended for its further maintenance are described in the ISO/IEC Directives, Part 1. In particular the different approval criteria needed for the different types of ISO documents should be noted. This document was drafted in accordance with the editorial rules of the ISO/IEC Directives, Part 2. www.iso.org/directives

Attention is drawn to the possibility that some of the elements of this document may be the subject of patent rights. ISO shall not be held responsible for identifying any or all such patent rights. Details of any patent rights identified during the development of the document will be in the Introduction and/or on the ISO list of patent declarations received. www.iso.org/patents

Any trade name used in this document is information given for the convenience of users and does not constitute an endorsement.

For an explanation on the meaning of ISO specific terms and expressions related to conformity assessment, as well as information about ISO's adherence to the WTO principles in the Technical Barriers to Trade (TBT) see the following URL: [Foreword - Supplementary information](#)

The committee responsible for this document is ISO/TC 135, *Non-destructive testing*, Subcommittee SC 2, and by Technical Committee CEN/TC 138, *Non-destructive testing* in collaboration.

This second edition cancels and replaces the first edition (ISO 3452-3:1998), which has been technically revised. It also incorporates the Technical Corrigendum, ISO 3452-3:1998/Cor 1:2001.

ISO 3452 consists of the following parts, under the general title *Non-destructive testing — Penetrant testing*:

- *Part 1: General principles*
- *Part 2: Testing of penetrant materials*
- *Part 3: Reference test blocks*
- *Part 4: Equipment*
- *Part 5: Penetrant testing at temperatures higher than 50 °C*
- *Part 6: Penetrant testing at temperatures lower than 10 °C*

Non-destructive testing — Penetrant testing —

Part 3: Reference test blocks

1 Scope

This International Standard describes two types of reference blocks:

- Type 1 reference blocks are used to determine the sensitivity levels of both fluorescent and colour contrast penetrant product families;
- Type 2 reference blocks are used for routine assessment of the performance of both fluorescent and colour contrast penetrant testing.

The reference blocks are to be used in accordance with part 1 of this International Standard.

2 Normative references

The following referenced documents, in whole or in part, are normatively referenced in this document and are indispensable for its application. For dated references, only the edition cited applies. For undated references, the latest edition of the referenced document (including any amendments) applies.

EN 10088-1, *Stainless steels — Part 1: List of standard stainless steels*

EN 10204, *Metallic products — Types of inspection documents*

ISO 4957, *Tool steels*

ISO 10474, *Steel and steel products — Inspection documents*

ISO 15510, *Stainless steels — Chemical composition*

3 Description of reference blocks

The Type 1 reference block consists of a set of four nickel-chrome plated panels with 10 µm, 20 µm, 30 µm and 50 µm thickness of plating, respectively. The 10 µm, 20 µm, 30 µm and 50 µm panels can be used for determination of the sensitivity of fluorescent penetrant systems. The sensitivity of colour contrast penetrant systems is determined using the 30 µm and 50 µm panels.

The Type 2 reference block consists of a single panel of which one half has been plated with electroless nickel and a thin layer of chromium and the other half prepared to achieve areas of specific roughness. The plated side exhibits five star-shaped discontinuities.

4 Type 1 reference block design and dimensions

The Type 1 panels are rectangular in shape with typical dimensions of 35 mm × 100 mm × 2 mm (see [Figure 1](#)). Each panel consists of a uniform layer of nickel-chromium plated on to a brass base, the thickness of nickel-chromium being 10 µm, 20 µm, 30 µm and 50 µm respectively. Transverse cracks are made in each panel by stretching the panels in the longitudinal direction. The width to depth ratio of each crack should be approximately 1:20.

Dimensions in millimetres

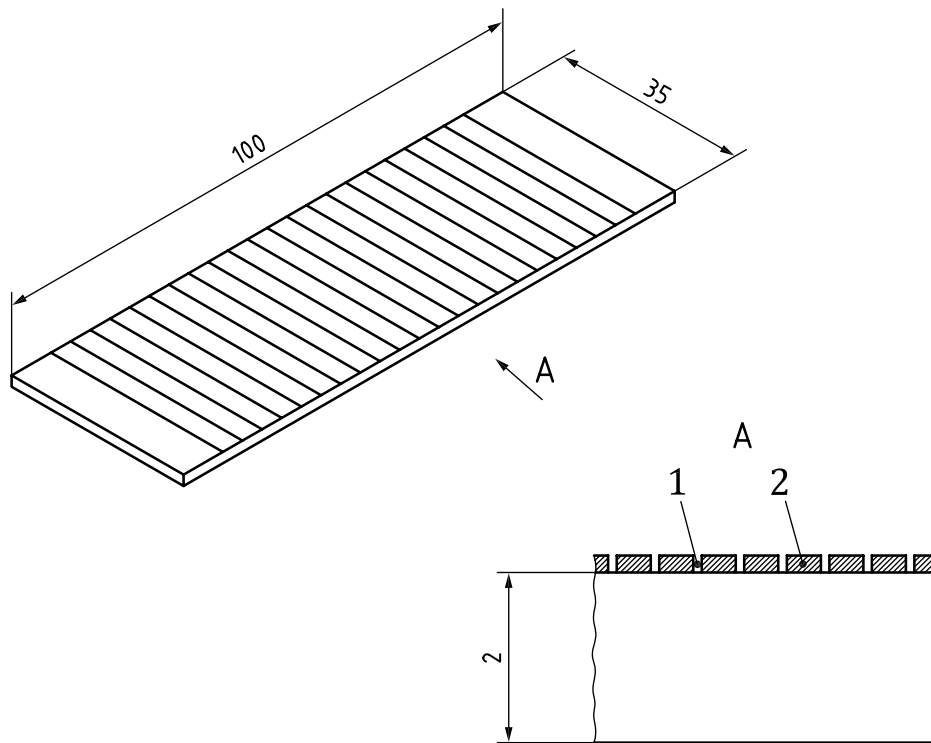

Key

- 1 Transverse cracks
- 2 Nickel chromium plating, thickness 10 µm, 20 µm, 30 µm or 50 µm

Figure 1 — Test panel, reference block Type 1 (schematic)

5 Type 2 reference block design and dimensions

5.1 Design

5.1.1 General

The test panel (see [Figure 2](#)) is rectangular in shape with dimensions of 155 mm × 50 mm × 2,5 mm.

NOTE All dimensional tolerances are ± 10 % unless otherwise stated.

The base material is a stainless steel type X2 Cr Ni Mo 17-12-3 according to EN 10088-1 and ISO 15510 with initial hardness of HV 20 = 150 ± 10 or equivalent.

Dimensions in millimetres

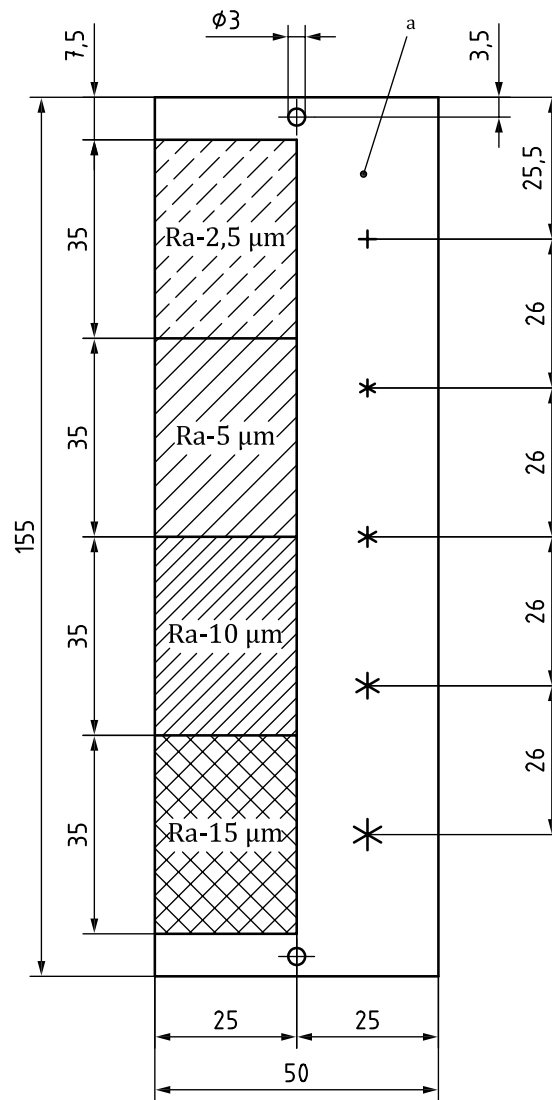

Figure 2 — Reference block Type 2

5.1.2 Rinsability area

For checking the rinsability of penetrants, four adjacent areas sized 25 mm by 35 mm are produced down on one half of the test surface of the panel with roughnesses of $R_a = 2,5 \mu\text{m}$, $R_a = 5 \mu\text{m}$, $R_a = 10 \mu\text{m}$ and $R_a = 15 \mu\text{m}$ (see [Figure 2](#)).

The area with $R_a = 2,5 \mu\text{m}$ may be produced by sand blasting and the other areas by electroerosion.

5.1.3 Defect area

5.1.3.1 General

The defect area is located on the other half of the test surface of the panel (see [Figure 2](#)).

5.1.3.2 Plating

A $60 \mu\text{m} \pm 3 \mu\text{m}$ thickness of electroless nickel shall be plated on to the test surface of the panel to achieve a hardness value ranging from HV 0,2 = 500 to 600.

The nickel layer shall be plated with a thin layer of hard chromium of 0,5 µm to 1,5 µm thickness. The panel shall then be heat treated to achieve a hardness value ranging from HV 0,3 = 900 to 1 000 by, for example, heating at 405 °C for 70 min. The roughness R_a of the chromium plating shall be 1,2 µm to 1,6 µm.

5.1.3.3 Artificial defect production

Five equidistant indentations shall be made under loads typically in the range 2 kN to 8 kN on the reverse side of the test surface (plated area).

For example, the production of the five artificial defects may be made using the following [Table 1](#).

Table 1 — Defect number

Defect	1	2	3	4	5
Applied force, kN	2,0	3,5	5,0	6,5	8,0

The indentations for artificial defect production are made using a compression machine (120 kN capacity) or an appropriate Vickers hardness machine fitted with a hemispherical indenter.

Details of the specific indenter are given in [Figure 3](#). The indentations are made using a speed loading of 0,05 kN/s and a speed unloading of 0,5 kN/s with continuous application of the load.

Dimensions in millimetres

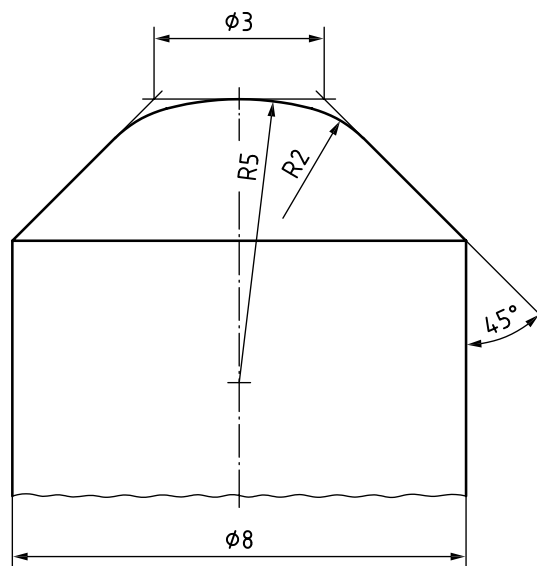

Figure 3 — Hemispherical indenter

Steel designation: 90 MnCrV8 according to ISO 4957 at quenched and tempered condition or equivalent quality of hardness HRC 53 to 62.

The five indentations shall be uniformly spaced and in size order, the smallest being adjacent to the least rough area.

The artificial defects shall lie within circles having the diameters given in [Table 2](#).

Table 2 — Typical diameter of crack areas

Defect number	Typical (diameter) dimensions (mm)
1	3
2	3,5
3	4
4	4,5
5	5,5

5.2 Measurement

The size of each defect is determined optically at its maximum diameter using calibrated scales.

A certificate, Type 3.1 according to ISO 10474 or EN 10204, giving the actual measured values of the five artificial defects and the roughnesses of the four rinsability areas shall accompany each reference block.

6 Identification

Each Type 1 reference block (set of panels) shall be identified with ISO 3452-3 followed by the identification of the supplier and a serial number. Each Type 2 reference block shall be identified with ISO 3452-3 followed the identification of the supplier and by serial number.

A declaration stating conformance to ISO 3452-3 and in line with ISO 10474 or EN 10204 Type 3.1 shall accompany each test block.

Bibliography

- [1] EN 10027-1, *Designation systems for steel — Part 1: Steel names, principal symbols*

ICS 19.100

Price based on 6 pages