

INTERNATIONAL STANDARD

ISO 3449

Fifth edition
2005-09-15

Earth-moving machinery — Falling-object protective structures — Laboratory tests and performance requirements

*Engins de terrassement — Structures de protection contre les chutes
d'objets — Essais de laboratoire et critères de performance*



Reference number
ISO 3449:2005(E)

© ISO 2005

PDF disclaimer

This PDF file may contain embedded typefaces. In accordance with Adobe's licensing policy, this file may be printed or viewed but shall not be edited unless the typefaces which are embedded are licensed to and installed on the computer performing the editing. In downloading this file, parties accept therein the responsibility of not infringing Adobe's licensing policy. The ISO Central Secretariat accepts no liability in this area.

Adobe is a trademark of Adobe Systems Incorporated.

Details of the software products used to create this PDF file can be found in the General Info relative to the file; the PDF-creation parameters were optimized for printing. Every care has been taken to ensure that the file is suitable for use by ISO member bodies. In the unlikely event that a problem relating to it is found, please inform the Central Secretariat at the address given below.

© ISO 2005

All rights reserved. Unless otherwise specified, no part of this publication may be reproduced or utilized in any form or by any means, electronic or mechanical, including photocopying and microfilm, without permission in writing from either ISO at the address below or ISO's member body in the country of the requester.

ISO copyright office
Case postale 56 • CH-1211 Geneva 20
Tel. + 41 22 749 01 11
Fax + 41 22 749 09 47
E-mail copyright@iso.org
Web www.iso.org

Published in Switzerland

Contents

Page

Foreword	iv
Introduction	v
1 Scope	1
2 Normative references	1
3 Terms and definitions	2
4 General	2
5 Laboratory tests	4
6 Performance requirements	8
7 Labelling	9
8 Reporting of test results	10
Annex A (normative) Typical test report	11
Bibliography	13

Foreword

ISO (the International Organization for Standardization) is a worldwide federation of national standards bodies (ISO member bodies). The work of preparing International Standards is normally carried out through ISO technical committees. Each member body interested in a subject for which a technical committee has been established has the right to be represented on that committee. International organizations, governmental and non-governmental, in liaison with ISO, also take part in the work. ISO collaborates closely with the International Electrotechnical Commission (IEC) on all matters of electrotechnical standardization.

International Standards are drafted in accordance with the rules given in the ISO/IEC Directives, Part 2.

The main task of technical committees is to prepare International Standards. Draft International Standards adopted by the technical committees are circulated to the member bodies for voting. Publication as an International Standard requires approval by at least 75 % of the member bodies casting a vote.

Attention is drawn to the possibility that some of the elements of this document may be the subject of patent rights. ISO shall not be held responsible for identifying any or all such patent rights.

ISO 3449 was prepared by Technical Committee ISO/TC 127, *Earth-moving machinery*, Subcommittee SC 2, *Safety requirements and human factors*.

This fifth edition cancels and replaces the fourth edition (ISO 3449:1992), which has been technically revised.

Introduction

This International Standard provides performance criteria for falling-object protective structures (FOPS). It recognizes that there are various classes and sizes of machines that operate in a variety of environmental conditions. It is intended to assure operators of reasonable protection from falling objects of different sizes and masses.

Its laboratory tests are a means of evaluating the characteristics of the structures used to protect the operator from localized impact penetration and, indirectly, of the load-carrying capacity of the supporting structure to resist impact loading.

This International Standard establishes a consistent, repeatable means of evaluating characteristics of FOPS under loading and prescribes performance requirements for these structures under such loading in a representative test.

For similar tests on FOPS for excavators and excavator-based machines, see ISO 10262.

Earth-moving machinery — Falling-object protective structures — Laboratory tests and performance requirements

1 Scope

This International Standard specifies laboratory tests for measuring the structural characteristics of, and gives performance requirements in a representative test for, falling-object protective structures (FOPS) intended for use on ride-on earth-moving machines as defined in ISO 6165. It is applicable to both FOPS supplied as an integral part of the machine and those supplied separately for attachment to the machine. It is not intended to apply to FOPS intended for use on landfill compactors, excavators, rollers, trenchers, pipelayers, for the additional seat for operation of an attachment (e.g. attachment backhoe), or on machines with a power rating of less than 15 kW.

NOTE This International Standard can be used to provide guidance to the manufacturers of roll-over or falling-object protective structures should it be decided to provide such protection for these or other machines for a particular application.

2 Normative references

The following referenced documents are indispensable for the application of this document. For dated references, only the edition cited applies. For undated references, the latest edition of the referenced document (including any amendments) applies.

ISO 148:1983, *Steel — Charpy impact test (V-notch)*¹⁾

ISO 898-1:1999, *Mechanical properties of fasteners made of carbon steel and alloy steel — Part 1: Bolts, screws and studs*

ISO 898-2:1992, *Mechanical properties of fasteners — Part 2: Nuts with specified proof load values — Coarse thread*

ISO 3164:1995, *Earth-moving machinery — Laboratory evaluations of protective structures — Specifications for deflection-limiting volume*

ISO 3471:1994, *Earth-moving machinery — Roll-over protective structures — Laboratory tests and performance requirements*

ISO 6165:—²⁾, *Earth-moving machinery — Basic types — Vocabulary*

1) Under revision.

2) To be published. (Revision of ISO 6165:2001)

3 Terms and definitions

For the purposes of this document, the following terms and definitions apply.

3.1 falling-object protective structure FOPS

system of structural members arranged in such a way as to provide operators with reasonable protection from falling objects (trees, rocks, small concrete blocks, hand tools, etc.)

3.2 roll-over protective structure ROPS

system of structural members whose primary purpose is to reduce the possibility of a seat-belted operator being crushed should the machine roll-over

NOTE Structural members include any subframe, bracket, mounting, socket, bolt, pin, suspension or flexible shock absorption used to secure the system to the machine frame, but exclude mounting provisions that are integral with the machine frame.

3.3 deflection-limiting volume DLV

orthogonal approximation of a large male, seated operator wearing normal clothing and a hard hat

NOTE See ISO 3164.

3.4 level I impact protection

impact strength for protection from small falling objects (e.g. bricks, small concrete blocks, hand tools) encountered in operations such as highway maintenance, landscaping and other construction site services

3.5 level II impact protection

impact strength for protection from heavy falling objects (e.g. trees, rocks) for machines involved in site clearing, overhead demolition or forestry

3.6 representative test

test of a specimen whose material, dimensional and processing requirements are typical of production FOPS

4 General

The FOPS may be integrated into the operator cab structure.

This test procedure is generally destructive of the FOPS assembly, as permanent deformation will occur to the structure, and might not reproduce structural deformations, owing to variation in the actual impact of the falling objects.

Two levels of performance criteria are specified for impact protection, based on the machine end use.

- a) Level I: protection against the impact of a round test object dropped from a height sufficient to develop an energy of 1 365 J. See Figures 1 a) and 2 a).
- b) Level II: protection against the impact of a cylindrical test object dropped from a height sufficient to develop an energy of 11 600 J. See Figures 1 b) and 2 b).

The drop height of the test object is defined as a function of its mass, as shown in Figure 1.

NOTE Although FOPS meeting these criteria do not give crush protection under all the circumstances in which the machine could be struck from above, it is expected that protection from penetration will be ensured under conditions a) and b).

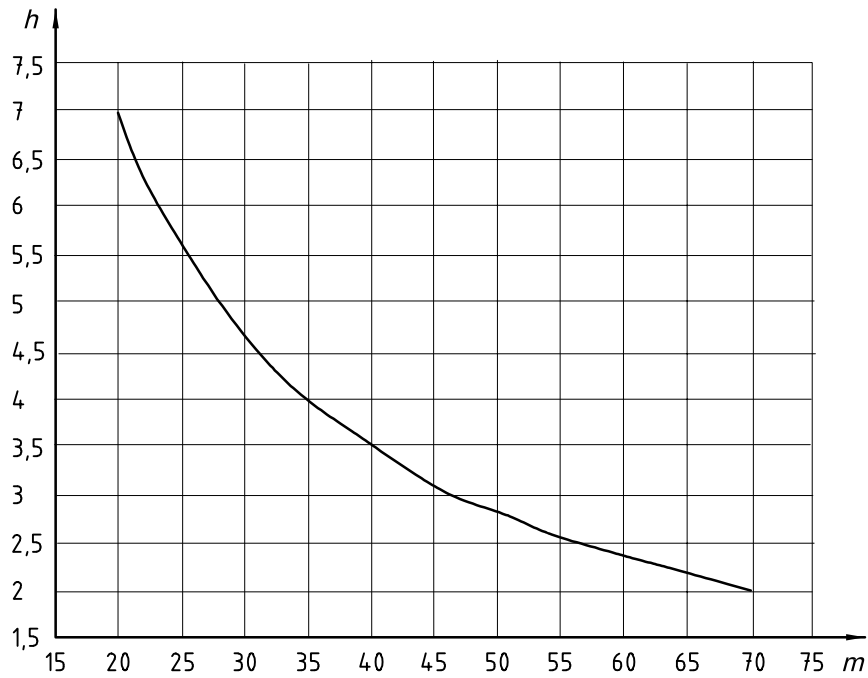

EXAMPLE $45 \text{ kg} \times 9,807 \text{ m/s}^2 \times 3,1 \text{ m} \approx 1\,365 \text{ J}$

a) Level I energy requirement curve

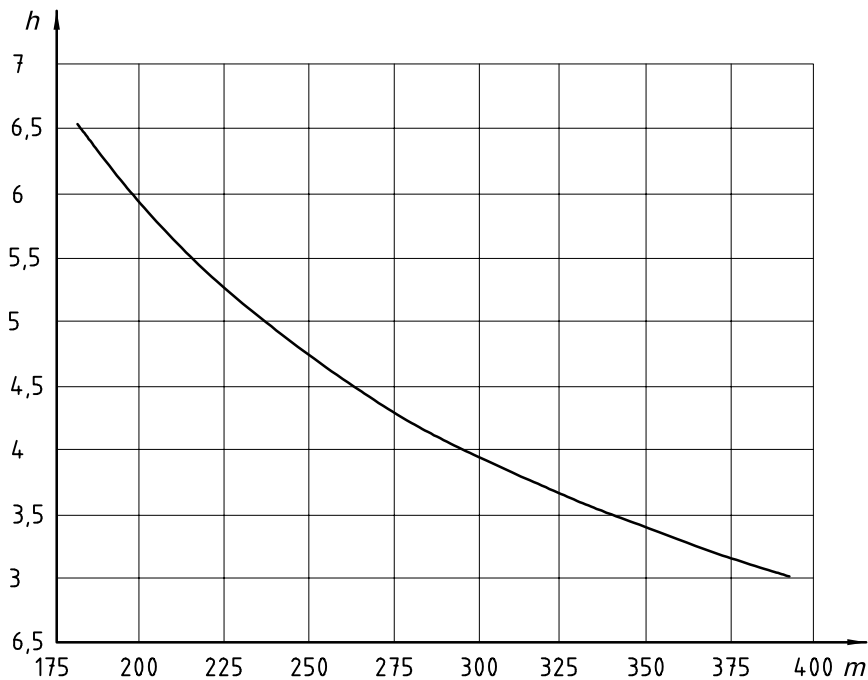

EXAMPLE $227 \text{ kg} \times 9,807 \text{ m/s}^2 \times 5,22 \text{ m} \approx 11\,600 \text{ J}$

b) Level II energy requirement curve

Key

- h* height, m
- m* mass, kg

Figure 1 — Height and mass for test object with capability of developing energy requirements

5 Laboratory tests

5.1 Test apparatus

5.1.1 Test object, whose impact surface has properties to protect against deformation during testing, and which

- for level I testing, has a solid steel or ductile iron cylinder, as shown in Figure 2 a), a typical mass of 45 kg and a spherical contact surface diameter of between 200 mm and 250 mm, and
- for level II testing, has a solid steel or ductile iron cylinder, as shown in Figure 2 b), and a typical mass of 227 kg.

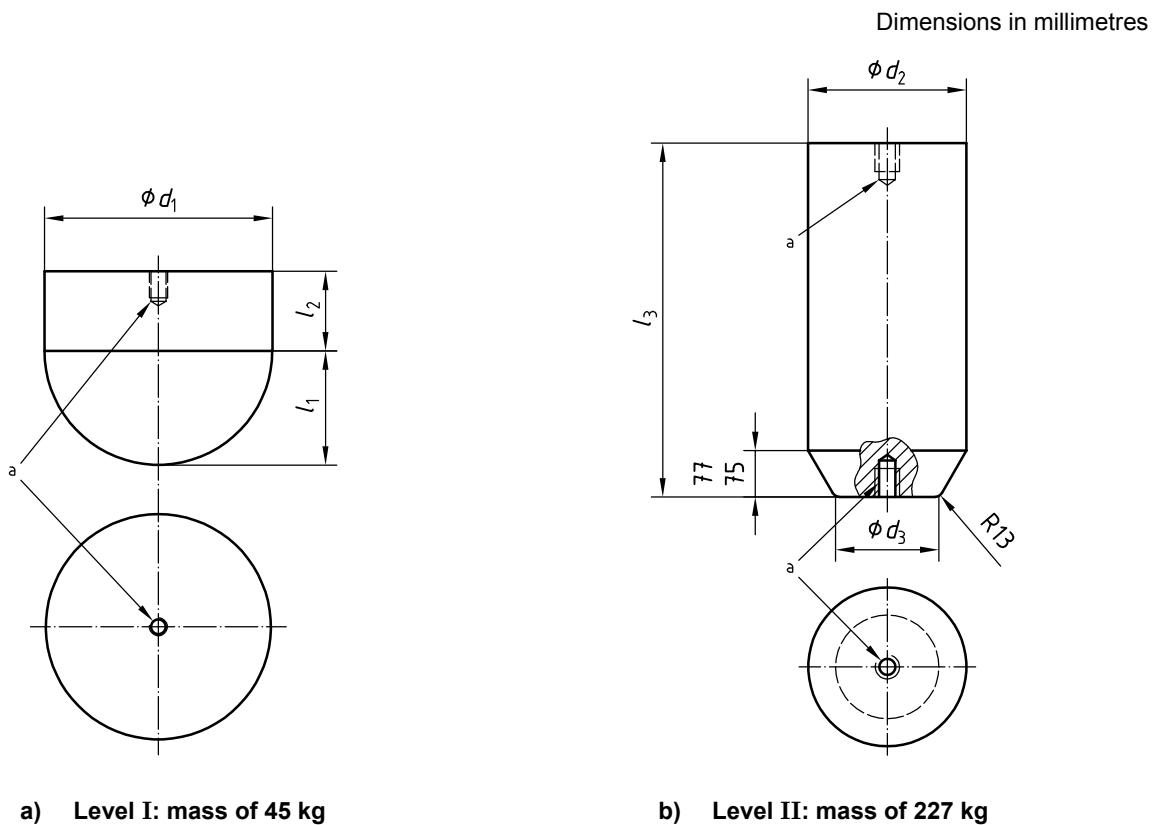

Key

- d_1 204 mm
- d_2 255 mm to 260 mm
- d_3 203 mm to 204 mm
- l_1 \approx 102 mm
- l_2 \approx 109 mm
- l_3 \approx 584 mm

NOTE 1 Actual values of dimensions are given here as examples.

NOTE 2 All the dimensions specified are variable, depending on the mass of the test object required to match the height of drop that will provide the energy according to Clause 4 a) and b). Dimensions of the drop test object are determined with respect to both its mass and drop-height (as determined from Figure 1), to provide the required energy.

a May be drilled and tapped for lifting eye.

Figure 2 — Example of test object

5.1.2 Test facility apparatus that provides a means to

- a) raise the test object to the required height,
- b) release it so that it drops without restraint, and
- c) determine whether the FOPS enters the deflection-limiting volume (DLV) during the test.

The means of determining c) may be either 5.1.3 or 5.1.4.

5.1.3 DLV structure, placed upright and made of a material that will indicate any penetration by the FOPS — grease or other suitable material being permitted to be put on the lower surface of the FOPS cover to indicate such penetration.

The DLV structure and its location shall be in accordance with ISO 3164. The DLV structure shall be fixed firmly to the same part of the machine as the operator's seat and shall remain there during the entire formal test period.

5.1.4 Suitable dynamic instrumentation system, with a dynamic measurement accuracy of $\pm 5\%$, for measuring the expected deflection of the FOPS with respect to the DLV.

5.2 Test conditions

5.2.1 Test bed

The FOPS to be evaluated shall be attached to the machine structure, as it would be in actual machine use. Although a complete machine is not required, the portion on which the FOPS is mounted shall be identical to the actual structure, and the vertical stiffness of the test bed shall be not less than that of an actual machine according to 5.2.2.

5.2.2 Machine-mounted FOPS

For FOPS mounted on a machine:

- the machine may be provided with equipment or attachments as specified by the manufacturer;
- all ground-engaging tools shall be in the normal transport position;
- all suspension systems, including pneumatic tyres, shall be set at operating levels, and variable suspensions shall be in the “maximum stiffness” range;
- all cab elements, such as windows, normally removable panels or non-structural fittings, shall be removed so that they do not contribute to the strength of the FOPS.

5.3 Test procedure

5.3.1 FOPS

The test procedure shall be performed as follows, in the sequence given.

- a) Place the test object on top of the FOPS, with the small end downwards for level II, at the impact location. The impact location shall touch, or be within the vertical projection of, the uppermost plane area of the DLV, as specified in the following three cases and shown in Figure 3. Major FOPS structural members that have a significant effect on FOPS deformation need to be considered according to each of these cases.

- 1) Where major, upper, horizontal members of the FOPS *do not* enter the vertical projection of the DLV on the FOPS top, select the test object impact location so as to produce the greatest deformation towards the uppermost horizontal plane of the DLV and be as close to the centroid of the FOPS structure as possible. See Figure 3 a).
 - 2) Where major, upper, horizontal members of the FOPS *do* enter the vertical projection of the DLV on the FOPS upper structural member, and the covering material of all the surface areas above the DLV is the same and of uniform thickness, select the test object impact location so as to produce the greatest deformation over, partially over, or tangent with, the uppermost horizontal plane of the DLV (depending on structure), with the least possible distance from the centroid, and outside the area of any upper structural member of the FOPS. See Figure 3 b).
 - 3) Where different materials or a different thickness are used in different areas above the DLV, subject each area to an impact test. Select the test object impact location for each area so as to produce the greatest deformation over, partially over, or tangent with, the uppermost horizontal plane of the DLV, with the least possible distance from the centroid, but outside the area of any upper structural members of the FOPS. If cut-outs in the FOPS cover are intended to be filled with devices or equipment to provide adequate protection, those devices or equipment shall be in place during the test. See Figure 3 c).
- b) Raise the test object vertically to a height above the position indicated in a) of this subclause to develop energy in accordance with Clause 4 a) or b), depending on the type of FOPS being tested.
- c) Release the test object so that it falls without restraint onto the FOPS.

As it is unlikely that the free fall will result in the test object hitting at the exact location and/or in the attitude according to a), the following limits are placed on deviations.

- For a level II FOPS, the initial impact of the small end of the test object shall be entirely within a circle of 200 mm radius whose centre coincides with the vertical centre line of the test object as positioned according to a).
- For a level I FOPS, the impact of the test sphere shall be entirely within a circle of 100 mm radius whose centre coincides with the vertical centre-line of the test object as positioned according to a).
- For the level II FOPS test, the first contact between the test object and the FOPS shall only be along the small end and/or the radius contiguous to that end (see Figure 2).

There is no limitation on location or attitude of subsequent impacts due to rebound.

5.3.2 Integral FOPS/ROPS

For integral FOPS/ROPS, if the same structure is used for the evaluation of both, the FOPS test according to 5.3.1 shall precede the ROPS test (see ISO 3471). The removal of impact dents or replacement of the FOPS cover is permitted.

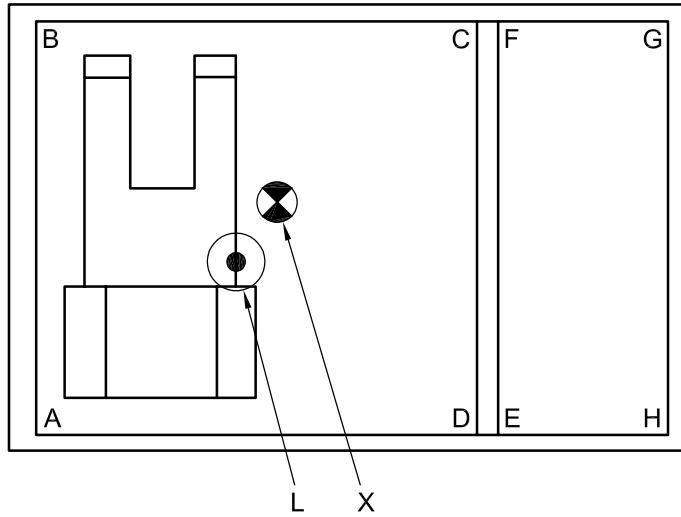

NOTE The centroid of the FOPS inside the major structural members is in area A, B, C, D.

a) Case 1

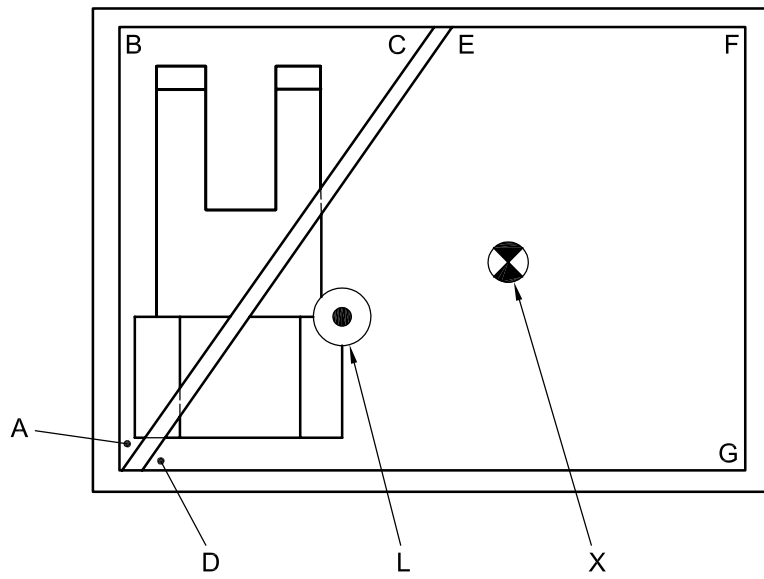

NOTE FOPS area A, B, C is less than area D, E, F, G, while the vertical projected DLV area is greater in the section represented by A, B, C.

b) Case 2

Figure 3 — Test impact locations

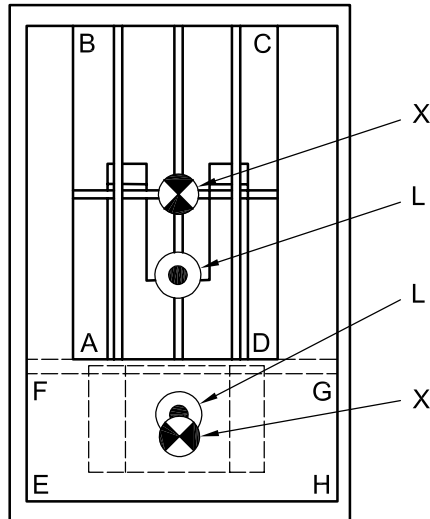

NOTE Impact location 1 is on FOPS area A, B, C, D. Impact location 2 is on FOPS area E, F, G, H.

c) Case 3

Key

- X centroid of FOPS surface area
- L impact location

Figure 3 (continued)

6 Performance requirements

6.1 FOPS

The protective properties of the FOPS system shall be evaluated according to the ability of the cab or protective structure to resist the impact. The FOPS shall completely cover and overlap the vertical projection of the DLV. The DLV shall not be entered by any part of the protective structure under the first or subsequent impact of the test object. Should the test object penetrate the FOPS, the FOPS shall be considered to have failed the test.

6.2 Integral FOPS/ROPS

Where the structure provides for ROPS and FOPS, the FOPS shall also meet the performance requirements for the appropriate ROPS as given in ISO 3471.

The FOPS of the integral FOPS/ROPS shall be in accordance with 6.1.

6.3 Material criteria

6.3.1 Material requirements

In addition to the impact requirements, there are material requirements for ensuring that the FOPS has meaningful resistance to brittle fracture. This does not necessarily relate to operating conditions. The material requirements can be verified by applying the test object impact at the test facility temperature if all FOPS structural members are fabricated from materials that meet the mechanical requirements given in 6.3.2 and 6.3.3. Alternatively, these requirements can be verified by applying the test object impact if all structural members are at, or below, - 18 °C. Steel less than 2,5 mm in thickness with a maximum carbon content of 0,2 % shall be considered as meeting the Charpy requirement.

6.3.2 Bolts and nuts

Bolts used structurally shall be metric property class 8.8, 9.8 or 10.9, as specified in ISO 898-1, or equivalent. Nuts used structurally shall be metric property class 8 or 10, as specified in ISO 898-2, or equivalent.

6.3.3 Structural members

The structural members of the FOPS and the mounts which attach it to the machine frame shall be made of steels that meet or exceed one of the Charpy V-notch (CVN) impact strengths at -20 °C or -30 °C given in Table 1.

NOTE The Charpy V-notch evaluation is primarily a quality control check for the toughness of steel and the indicated temperature does not directly relate to operating conditions.

Specimens shall be “longitudinal” and taken from flat stock, tubular or structural sections before forming or welding for use in the FOPS. Specimens from tubular or structural sections shall be taken from the middle of the side of greatest dimension and shall not include welds, in accordance with ISO 148.

Table 1 — Minimum Charpy V-notch impact strengths

Specimen size mm	Energy at	
	-30 °C J	-20 °C^b J
10×10^a	11	27,5
10×9	10	25
10×8	9,5	24
$10 \times 7,5^a$	9,5	24
10×7	9	22,5
$10 \times 6,7$	8,5	21
10×6	8	20
10×5^a	7,5	19
10×4	7	17,5
$10 \times 3,3$	6	15
10×3	6	15
$10 \times 2,5^a$	5,5	14

^a Indicates preferred size. Specimen size shall be no less than the largest preferred size that the material will permit.

^b The energy requirements at -20 °C is 2,5 times the value specified for -30 °C . Other factors affect impact energy strength, i. e. direction of rolling, yield strength, grain orientation and welding. These factors shall be considered when selecting and using a steel.

7 Labelling

A label shall be applied to every FOPS. When the structure meets the performance requirements for both FOPS and ROPS, the ROPS labelling shall be in accordance with ISO 3471.

The label shall be of a permanent type and permanently attached to the structure. The label and its contents shall be of a size that is legible.

The label shall be located on the structure so that it can be easily read and so that it is protected from defacing by the weather.

The label shall provide the following minimum information:

- a) name and address of the manufacturer or constructor of the FOPS;
- b) FOPS identification number, if any;
- c) machine make, model(s), or product identification number(s) the structure is designed to fit;
- d) International Standard number(s) for which the structure meets all of the performance requirements and the level being met (national regulations may be included);
- e) Year of construction for FOPS, supplied separately for attachment to a machine.

A combined FOPS/ROPS label shall include information from a) and c) of this clause.

The manufacturer may include such other information as deemed appropriate (e.g. installation, repair or replacement information).

8 Reporting of test results

The test report shall include the results of the test. For a typical test report see Annex A.

Annex A (normative)

Typical test report

A.1 Identification

A.1.1 Machine(s)

Type:

Manufacturer:

Model:

Product identification number:

Machine frame part number:

A.1.2 FOPS

Manufacturer:

Model:

Serial number (if any):

FOPS (may include ROPS) part number:

A.2 Information supplied by test facility

A.2.1 Test object description

Performance level tested:

Mass: kg

Drop height: m

Test object dimensions (sketch optional).

Documentation of impact location(s) showing location relative to DLV.

A.2.2 Photographs

One photograph of test object and test arrangement before application of test(s).

Additional photographs as necessary to show top and bottom of FOPS structure after the test(s).

A.2.3 Test results

A.2.3.1 Impact Test

Energy imparted to the test object without causing penetration of any part of the FOPS structure into the DLV nor penetration of the FOPS by the test object: J

A.2.3.2 Material criteria

The test was performed with FOPS and machine frame members soaked to °C

or

Verification of the Charpy V-notch impact strength requirements for FOPS and ROPS (or FOPS cover) structural metallic members:

Verification of the property class requirements for bolts and nuts (see 6.3.2):.....

A.3 Conclusion

Minimum performance requirements of ISO 3449 (level I or II) were met/not met in this test.

Date of test:

Name and address of the test facility:

Tested by (signature)

Date of report:

Bibliography

- [1] ISO 10262, *Earth-moving machinery — Hydraulic excavators — Laboratory tests and performance requirements for operator protective guards*

