

**INTERNATIONAL STANDARD ISO 3419-1981 (E)/ERRATUM**

Published 1982-09-01

INTERNATIONAL ORGANIZATION FOR STANDARDIZATION • МЕЖДУНАРОДНАЯ ОРГАНИЗАЦИЯ ПО СТАНДАРТИЗАЦИИ • ORGANISATION INTERNATIONALE DE NORMALISATION

**Non-alloy and alloy steel butt-welding fittings****ERRATUM***Page 10*

Column "T", DN = 80, line 1 : Delete "3,6" and substitute "3,2".

3419-81

4851903 0025137 0



International Standard

3419

G-65-07

INTERNATIONAL ORGANIZATION FOR STANDARDIZATION • МЕЖДУНАРОДНАЯ ОРГАНИЗАЦИЯ ПО СТАНДАРТИЗАЦИИ • ORGANISATION INTERNATIONALE DE NORMALISATION

## Non-alloy and alloy steel butt-welding fittings

*Accessoires à souder bout à bout en acier non allié et allié*

Second edition — 1981-07-15

UDC 621.643.411.4

Ref. No. ISO 3419-1981 (E)

**Descriptors** : piping, steel tubes, pipe fittings, unalloyed steels, alloy steels, pipe bends, welded tubes, designation, symbols, dimensions, dimensional tolerances, marking, pipe caps.

Price based on 17 pages

ISO 3419-1981 (E)

## Foreword

ISO (the International Organization for Standardization) is a worldwide federation of national standards institutes (ISO member bodies). The work of developing International Standards is carried out through ISO technical committees. Every member body interested in a subject for which a technical committee has been set up has the right to be represented on that committee. International organizations, governmental and non-governmental, in liaison with ISO, also take part in the work.

Draft International Standards adopted by the technical committees are circulated to the member bodies for approval before their acceptance as International Standards by the ISO Council.

International Standard ISO 3419 was developed by Technical Committee ISO/TC 5, *Metal pipes and fittings*, and was circulated to the member bodies in November 1979.

It has been approved by the member bodies of the following countries :

Australia	Germany, F.R.	South Africa, Rep. of
Austria	Hungary	Spain
Belgium	India	Sweden
Brazil	Israel	Switzerland
Canada	Italy	USA
Czechoslovakia	Korea, Rep. of	USSR
Finland	Netherlands	
France	Romania	

The member bodies of the following countries expressed disapproval of the document on technical grounds :

Japan  
United Kingdom

This second edition cancels and replaces the first edition (i.e. ISO 3419-1975).

3419-81

4851903 0025139 4

# Non-alloy and alloy steel butt-welding fittings

## 1 Scope and field of application

This International Standard specifies the dimensions, tolerances and generally used grades of non-alloy, low-alloy and alloy steels for butt-welding bends (type 2D (90° and 180°) and 3D (45°, 90° and 180°), concentric and eccentric reducers, tees, caps and stub ends with quality requirements as used for piping work.

## 2 References

ISO 404, *Steel and steel products — General technical delivery requirements.*<sup>1)</sup>

ISO 2604/2, *Steel products for pressure purposes — Quality requirements — Part 2 : Wrought seamless tubes.*

ISO 2604/3, *Steel products for pressure purposes — Quality requirements — Part 3 : Electric resistance and induction-welded tubes.*

ISO 2604/4, *Steel products for pressure purposes — Quality requirements — Part 4 : Plates.*

ISO 3183, *Oil and natural gas industries — Steel line pipe.*<sup>2)</sup>

ISO 3545, *Steel tubes and tubular shaped accessories with circular cross-section — Symbols to be used in specifications for steel tubes.*<sup>2)</sup>

ISO 3845, *Oil and natural gas industries — High-test steel line pipe.*<sup>2)</sup>

ISO 4200, *Plain end steel tubes, welded and seamless — General tables of dimensions and conventional masses per unit length.*

ISO 6708, *Pipe components — Definition of nominal size.*

## 3 Designation

The fittings shall be designated by the type (i.e. bend, reducer, cap, tee, stub end), the angle (for bends), the outside diameter(s), the thickness, and the grade of steel followed by a reference to this International Standard.

1) At present at the stage of draft. (Revision of ISO/R 404-1964.)

2) At present at the stage of draft.

### Example of designation :

Butt-welding bend 3D-90-60,3 × 2,9-TS 4 ISO 3419

Supplementary requirements may be agreed between the purchaser and the manufacturer and shall be specified in the enquiry and order.

## 4 Definitions and symbols

DN	= Nominal size (see ISO 6708)
$D$	= Major outside diameter
$D_1$	= Minor outside diameter
$d$	= Major inside diameter
$d_1$	= Minor inside diameter
$T$	= Thickness adjacent to $D$
$T_1$	= Thickness adjacent to $D_1$
$C$	= Centreline dimension for 180° bends
$B$	= Dimension from the back to the face for 180° bends
$F$	= Dimension from centreline to the face $d$ for 90° bends, for equal tees and for reducing tees
$H$	= Dimension from centreline tangent intersection to face for 45° bends and from centreline to face at $d_1$ for reducing tees
$K$	= Total height of caps
$L$	= Overall length of reducers
$R, R_1$	= Radii of curves of bends and reducers
$Q$	= Tolerance for angular alignment
$U$	= Tolerance for alignment of faces of 180° bends
$P$	= Tolerance for perpendicular alignment

## 5 Materials

5.1 The grades of steel to be used are as follows :

TS4, TS9, TS10, TS18, TS32, TS34, TS37, TS43  
(ISO 2604/2)

TW4, TW9, TW10 (ISO 2604/3)

P5, P9, P18, P32, P34, P43 (ISO 2604/4)

E24-1, E24-2 (ISO 3183)

E29, E32, E36, E39, E41, E45 (ISO 3845)

5.2 Other grades of steel specified in ISO 2604/2, ISO 2604/3 and ISO 2604/4 may be supplied by agreement between the purchaser and manufacturer.

5.3 The fittings shall be manufactured from

- a) seamless tubes;
- b) welded tubes or welded plate material; the welds shall be made with filler metal and tested by a non-destructive method to be agreed between purchaser and manufacturer;
- c) plate.

## 6 Dimensions and tolerances

### 6.1 Dimensions

The dimensions are specified in the tables below :

#### 6.1.1 Bends 2D

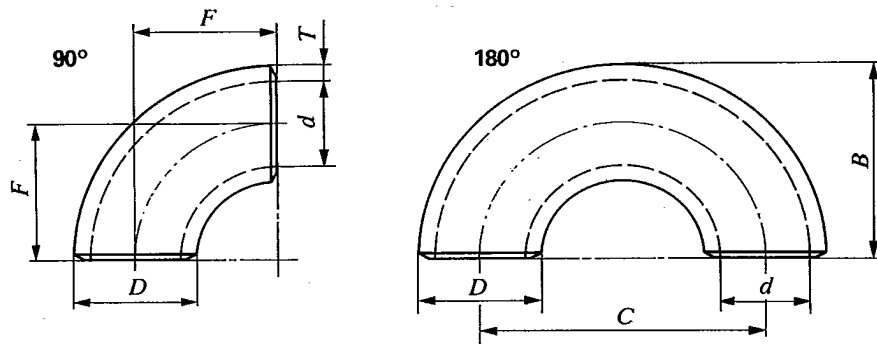

Figure 1 — Bends 2D

NOTE — Taking account of current usage and manufacture, only two series of thicknesses are specified.

Table 1 — Dimensions of bends 2D

DN	D mm	T mm	F mm	C mm	B mm	Conventional mass <sup>1)</sup> kg ≈ Bend 90°
50	60,3	4 5,6	51	102	81	0,44 0,60
65	76,1	5 7,1	63	127	102	0,87 1,2
80	88,9	5,6 8	76	152	121	1,4 1,9
100	114,3	6,3 8,8	102	203	159	2,6 3,6
125	139,7	6,3 10	127	254	197	4,1 6,4
150	168,3	7,1 11	152	305	237	6,7 10
200	219,1	8 12,5	203	406	313	13 20
250	273	10	254	508	391	26
300	323,9	10	305	610	467	37
350	355,6	11	356	711	533	52
400	406,4	12,5	406	813	610	77
450	457		457	914	686	
500	508		508	1 016	762	
600	610		610	1 220	914	

1) For information only.

6.1.2 Bends 3D

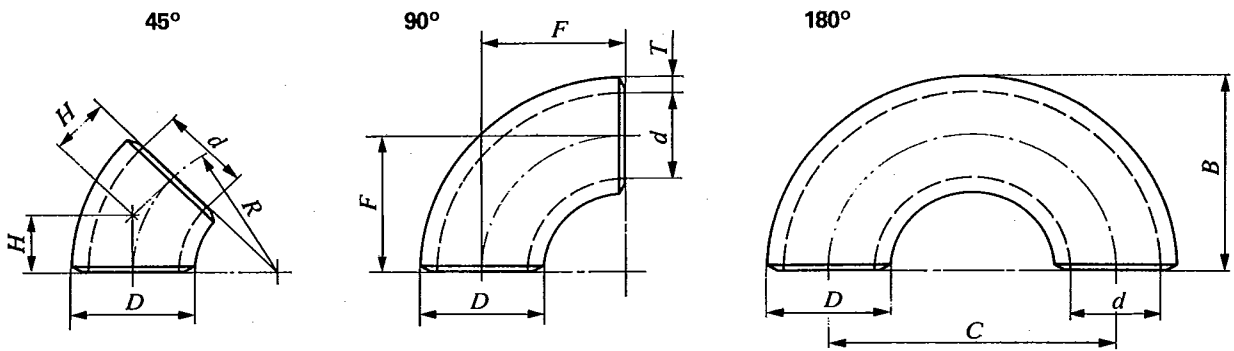

Figure 2 – Bends 3D

Table 2 – Dimensions of bends 3D

DN	D mm	T mm	F and R mm	H mm	C mm	B mm	Conventional mass <sup>1)</sup> kg ≈ Bends		
							45°	90°	180°
15	21,3	2	28	14	56	38	0,02	0,04	0,08
		3,2					0,06	0,12	
		4					0,07	0,14	
20	26,9	2	29	14	58	43	0,03	0,06	0,11
		3,2					0,08	0,17	
		4					0,10	0,20	
25	33,7	2,3	38	22	76	56	0,05	0,11	0,21
		3,2					0,16	0,32	
		4,5					0,19	0,38	
32	42,4	2,6	48	25	96	69	0,10	0,19	0,39
		3,6					0,26	0,52	
		5					0,35	0,60	
40	48,3	2,6	57	29	114	82	0,13	0,26	0,53
		3,6					0,36	0,72	
		5					0,47	0,95	
50	60,3	2,9	76	35	152	106	0,25	0,50	0,99
		4					0,67	1,3	
		5,6					0,89	1,8	
65	76,1	2,9	95	44	190	133	0,40	0,79	1,6
		5					1,5	2,9	
		7,1					1,8	3,6	
80	88,9	3,2	114	51	228	159	0,60	1,2	2,4
		5,6					2,1	4,1	
		8					2,8	5,7	
100	114,3	3,6	152	64	304	210	1,2	2,4	4,7
		6,3					4,0	8,0	
		8,8					5,4	11	
125	139,7	4	190	79	380	260	2,0	4,0	8,0
		6,3					6,2	12	
		10					9,6	19	

1) For information only.

Table 2 (concluded)

DN	D mm	T mm	F and R mm	H mm	C mm	B mm	Conventional mass <sup>1)</sup> kg $\approx$ Bends		
							45°	90°	180°
150	168,3	4,5 7,1 11	229	95	457	313	3,2 5,1 7,7	6,5 10 15	13 20 31
200	219,1	6,3 8 12,5	305	127	610	414	8,0 9,9 14	16 20 31	32 40 61
250	273	6,3 10	381	159	762	518	12 19	25 39	50 78
300	323,9	7,1 10	457	190	914	619	20 28	40 56	80 111
350	355,6	8 11	533	222	1 066	711	24 39	57 78	114 156
400	406,4	8,8 12,5	610	254	1 220	813	41 58	82 117	165 234
450	457	10	686	286	1 372	914	59 84	119 168	237 336
500	508	11	762	318	1 524	1 016	81	162	323
600	610	12,5	914	381	1 828	1 219	133	266	531
700	711		1 067	444	2 134	1 422			
800	813		1 219	507	2 238				
900	914		1 372	570	2 744				
1 000	1 016		1 524	634	3 048				

1) For information only.



6.1.3 Concentric and eccentric reducers

Recommended radii :

Concentric reducers  $R > 0,4 D$   
 $R_1 > 0,4 D_1$

Eccentric reducers  $R > 0,3 D$   
 $R_1 > 0,3 D_1$

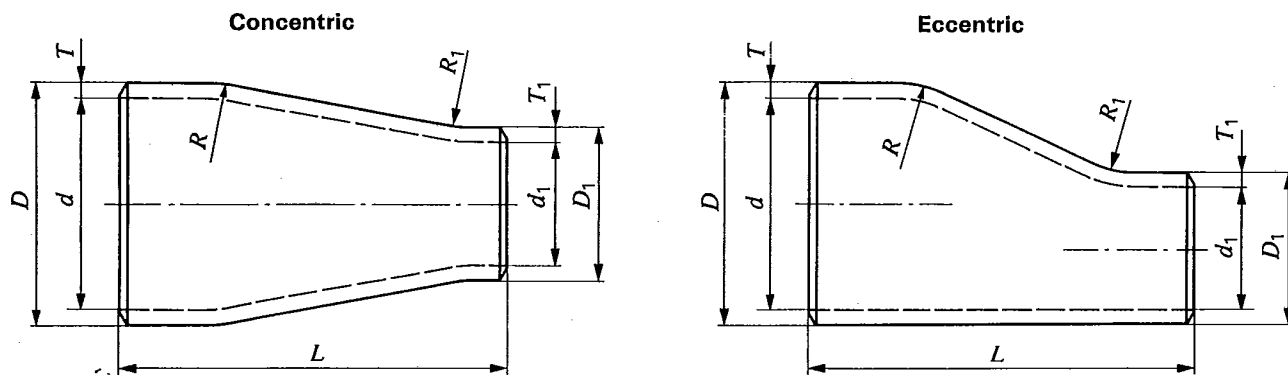

Figure 3 — Concentric and eccentric reducers

Table 3 — Dimensions of reducers

DN	Major diameter		Minor diameter		L mm	Conventional mass <sup>1)</sup> kg ≈
	D mm	T mm	D <sub>1</sub> mm	T <sub>1</sub> mm		
20	26,9	2	21,3	2	38	0,05
		3,2		3,2		0,07
		4		4		0,09
25	33,7	2,3	26,9	2	51	0,09
		3,2		3,2		0,12
		4,5		4		0,16
		2,3	21,3	2		0,09
		3,2		3,2		0,12
		4,5		4		0,16
32	42,4	2,6	33,7	2,3	51	0,13
		3,6		3,2		0,17
		5		4,5		0,23
		2,6	26,9	2		0,13
		3,6		3,2		0,17
		5		4		0,23
		2,6	21,3	2		0,13
		3,6		3,2		0,17
		5		4		0,23
40	48,3	2,6	42,4	2,6	64	0,19
		3,6		3,6		0,25
		5		5		0,34
		2,6	33,7	2,3		0,19
		3,6		3,2		0,25
		5		4,5		0,30
		2,6	26,9	2		0,19
		3,6		3,2		0,25
		5		4		0,34

1) For information only.

Table 3 (continued)

DN	Major diameter		Minor diameter		L mm	Conventional mass <sup>1)</sup> kg ≈
	D mm	T mm	D <sub>1</sub> mm	T <sub>1</sub> mm		
50	60,3	2,9	48,3	2,6	76	0,31
		4		3,6		0,42
		5,6		5		0,58
		2,9	42,4	2,6		0,31
		4		3,6		0,42
		5,6		5		0,58
		2,9	33,7	2,3		0,31
		4		3,2		0,42
		5,6		4,5		0,58
65	76,1	2,9	60,3	2,9	89	0,47
		5		4		0,78
		7,1		5,6		1,1
		2,9	48,3	2,6		0,47
		5		3,6		0,78
		7,1		5		1,1
		2,9	42,4	2,6		0,47
		5		3,6		0,78
		7,1		5		1,1
80	88,9	3,2	76,1	2,9	89	0,6
		5,6		5		1,0
		8		7,1		1,4
		3,2	60,3	2,9		0,6
		5,6		4		1,0
		8		5,6		1,4
		3,2	48,3	2,6		0,60
		5,6		3,6		1,0
		8		5		1,4
100	114,3	3,6	88,9	3,2	102	1,0
		6,3		5,6		1,7
		8,8		8		2,3
		3,6	76,1	2,9		1,0
		6,3		5		1,7
		8,8		7,1		2,3
		3,6	60,3	2,9		1,0
		6,3		4		1,7
		8,8		5,6		2,3
125	139,7	4	114,3	3,6	127	1,7
		6,3		6,3		2,6
		10		8,8		4,1
		4	88,9	3,2		1,7
		6,3		5,6		2,6
		10		8		4,1
		4	76,1	2,9		1,7
		6,3		5		2,6
		10		7,1		4,1
150	168,3	4,5	139,7	4	140	2,5
		7,1		6,3		3,9
		11		10		6,0
		4,5	114,3	3,6		2,5
		7,1		6,3		3,9
		11		8,8		6,0
		4,5	88,9	3,2		2,5
		7,1		5,6		3,9
		11		8		6,0

1) For information only.

Table 3 (concluded)

DN	Major diameter		Minor diameter		L mm	Conventional mass <sup>1)</sup> kg ≈
	D mm	T mm	D <sub>1</sub> mm	T <sub>1</sub> mm		
200	219,1	6,3	168,3	4,5	152	5,1
		8		7,1		6,3
		12,5		11		9,7
		6,3	139,7	4		5,1
		8		6,3		6,3
		12,5		10		9,7
		6,3	114,3	3,6		5,1
		8		6,3		6,3
		12,5		8,8		9,7
250	273	6,3	219,1	6,3	178	7,4
		10		8		12
		6,3		168,3		4,5
10	7,1	12				
6,3	139,7	4			7,4	
10		6,3		12		
300		323,9		7,1	273	6,3
	10		10	16		
	7,1		219,1	6,3		
10	8	16				
7,1	168,3	4,5			11	
10		7,1	16			
350		355,6	8		323,9	7,1
	11		10	31		
	8		273	6,3		
11	10	31				
8	219,1	6,3			23	
11		8	31			
400		406,4	8,8		355,6	8
	12,5		11	43		
	8,8		323,9	7,1		
12,5	10	43				
8,8	273	6,3			31	
12,5		10	43			
450		457	10		406,4	8,8
	10		8	42		
	10		7,1	42		
500	508	11	457	10	508	65
		11		8,8		65
		11		8		65
600	610	12,5	508	11	508	94
		12,5		10		94
		12,5		8,8		94
700	711		610	12,5	610	
				11		
				10		
800	813		711		610	
				12,5		
				11		
900	914		813		610	
				12,5		
1 000	1 016		914		610	
				12,5		
			711			

1) For information only.

## 6.1.4 Tees, equal and reducing

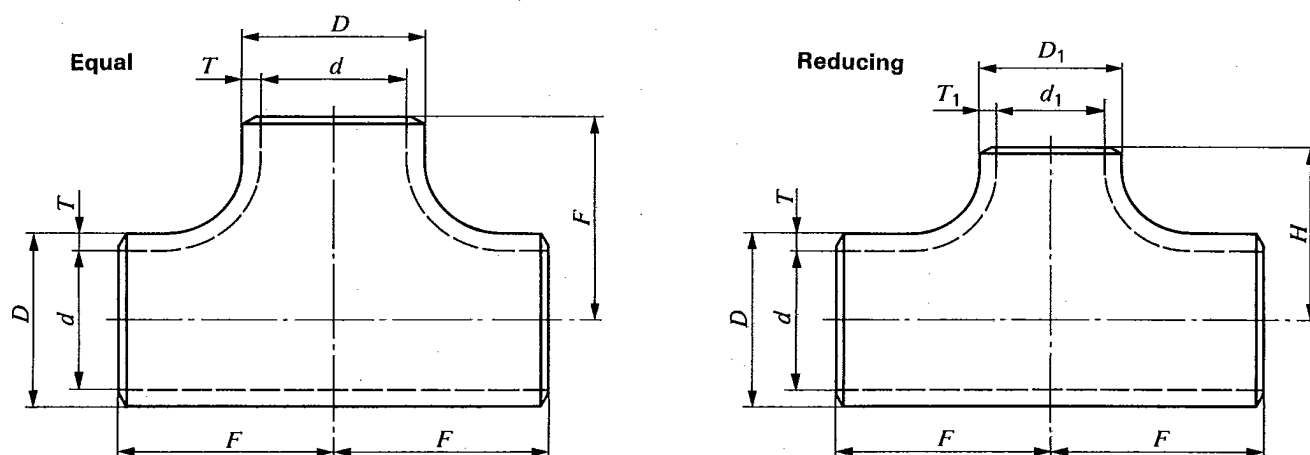

Figure 4 — Tees, equal and reducing

Table 4 — Dimensions of tees

DN	$D$ mm	$T$ mm	$D_1$ mm	$T_1$ mm	$F$ mm	$H$ mm	Conventional mass <sup>1)</sup> kg $\approx$
15	21,3	2	21,3	2	25	—	0,19
		3,2		3,2			0,30
		4		4			0,38
20	26,9	2	26,9	2	29	—	0,23
		3,2		3,2			0,37
		4		4			0,46
		2	21,3	2	29	29	0,26
		3,2		3,2			0,42
		4		4			0,52
25	33,7	2,3	33,7	2,3	38	—	0,40
		3,2		3,2			0,64
		4,5		4,5			0,80
		2,3	26,9	2	38	38	0,25
		3,2		3,2			0,35
		4,5		4			0,40
		2,3	21,3	2	38	38	0,25
		3,2		3,2			0,35
		4,5		4			0,40
32	42,4	2,6	42,4	2,6	48	—	0,79
		3,6		3,6			1,1
		5		5			1,5
		2,6	33,7	2,3	48	48	0,79
		3,6		3,2			1,1
		5		4,5			1,5
		2,6	26,9	2	48	48	0,79
		3,6		3,2			1,1
		5		4			1,5
		2,6	21,3	2	48	48	0,79
		3,6		3,2			1,1
		5		4			1,5

1) For information only.

Table 4 (continued)

DN	D mm	T mm	D <sub>1</sub> mm	T <sub>1</sub> mm	F mm	H mm	Conventional mass <sup>1)</sup> kg ≈
40	48,3	2,6 3,6 5	48,3	2,6 3,6 5	57	—	1,0 1,4 2,0
		2,6 3,6 5	42,4	2,6 3,6 5	57	57	1,0 1,4 2,0
		2,6 3,6 5	33,7	2,3 3,2 4,5	57	57	1,0 1,4 2,0
		2,6 3,6 5	26,9	2 3,2 4	57	57	1,0 1,4 2,0
50	60,3	2,9 4 5,6	60,3	2,9 4 5,6	64	—	1,6 2,2 3,0
		2,9 4 5,6	48,3	2,6 3,6 5	64	60	1,6 2,2 3,0
		2,9 4 5,6	42,4	2,6 3,6 5	64	57	1,6 2,2 3,0
		2,9 4 5,6	33,7	2,3 3,2 4,5	64	51	1,6 2,2 3,0
65	76,1	2,9 5 7,1	76,1	2,9 5 7,1	76	—	3,2 5,5 7,9
		2,9 5 7,1	60,3	2,9 4 5,6	76	70	3,2 5,5 7,9
		2,9 5 7,1	48,3	2,6 3,6 5	76	67	3,2 5,5 7,9
		2,9 5 7,1	42,4	2,6 3,6 5	76	64	3,2 5,5 7,9
80	88,9	3,6 5,6 8	88,9	3,2 5,6 8	86	—	2,5 4,5 6,2
		3,2 5,6 8	76,1	2,9 5 7,1	86	83	2,5 4,5 6,2
		3,2 5,6 8	60,3	2,9 4 5,6	86	76	2,2 4,0 5,5
		3,2 5,6 8	48,3	2,9 4 5,6	86	73	2,2 4,0 5,5
100	114,3	3,6 6,3 8,8	114,3	3,6 6,3 8,8	105	—	4,5 7,8 10
		3,6 6,3 8,8	88,9	3,2 5,6 8	105	98	4,5 7,8 10
		3,6 6,3 8,8	76,1	2,9 5 7,1	105	95	4,5 7,8 10
		3,6 6,3 8,8	60,3	2,7 4 5,6	105	89	3,8 6,7 10

1) For information only.

Table 4 (continued)

DN	D mm	T mm	D <sub>1</sub> mm	T <sub>1</sub> mm	F mm	H mm	Conventional mass <sup>1)</sup> kg ≈
125	139,7	4 6,3 10	139,7	4 6,3 10	124	—	3,4 5,3 16
		4 6,3 10	114,3	3,6 6,3 8,8	124	117	3,4 5,3 16
		4 6,3 10	88,9	3,2 5,6 8	124	111	3,4 5,3 16
		4 6,3 10	76,1	2,9 5 7,1	124	108	3,4 5,3 16
150	168,3	4,5 7,1 11	168,3	4,5 7,1 11	143	—	9,4 16 24
		4,5 7,1 11	139,7	4 6,3 10	143	137	9,4 16 24
		4,5 7,1 11	114,3	3,6 6,3 8,8	143	130	9,4 16 24
		4,5 7,1 11	88,9	3,2 5,6 8	143	124	9,4 16 24
200	219,1	6,3 8 12,5	219,1	6,3 8 12,5	178	—	23 29 44
		6,3 8 12,5	168,3	4,5 7,1 11	178	168	16 20 43
		6,3 8 12,5	139,7	4 6,3 10	178	162	16 20 43
		6,3 8 12,5	114,3	3,6 6,3 8,8	178	156	
250	273	6,3 10	273	6,3 10	216	—	33 52
		6,3 10	219,1	6,3 8	216	203	33 52
		6,3 10	168,3	4,5 7,1	216	194	33 52
		6,3 10	139,7	4 6,3	216	191	33 52
300	323,9	7,1 10	323,9	7,1 10	254	—	54 77
		7,1 10	273	6,3 10	254	241	54 77
		7,1 10	219,1	6,3 8	254	229	47 66
		7,1 10	168,3	4,5 7,1	254	219	47 66

1) For information only.

Table 4 (concluded)

DN	D mm	T mm	D <sub>1</sub> mm	T <sub>1</sub> mm	F mm	H mm	Conventional mass <sup>1)</sup> kg ≈	
350	355,6	8	355,6	8	279	—	68 94	
		11		11				
		8		323,9		7,1	279	270
		11		10				
400	406,4	8	406,4	8,8	305	—	88 131	
		12,5		12,5				
		8,8		355,6		8	305	305
		12,5		11				
450	457	8,8	323,9	7,1	305	295		
		12,5		10				
		8,8		273		6,3	305	283
		12,5		10				
500	508	10	457	10	343	—		
		10		406,4		8,8	343	330
		10		355,6		8	343	330
		10		11				
600	610	10	323,9	7,1	343	321		
		11		508		11	381	—
		11		457		10	381	368
		11		406,4		8,8	381	356
700	711	11	355,6	8	381	356		
		11		610		12,5	432	—
		12,5		508		11	432	432
		12,5		457		10	432	419
800	813	12,5	406,4	8,8	432	406		
		12,5		711		521	—	
		813		597		—		
		914		673		—		
900	914	914	914	673	—			
		1 000	1 016	1 016	749	—		

1) For information only.

## 6.1.5 Caps

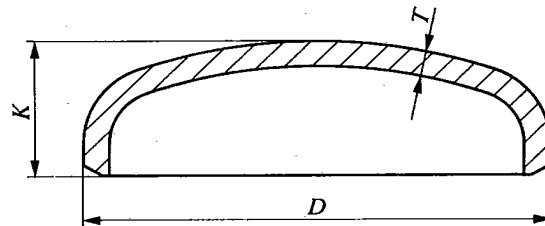

Figure 5 — Caps

NOTE — Caps are to be of semi-ellipsoid shape and are to have a length of straight section to make up the overall length as specified for  $K$ . The height of the semi-ellipsoid portion, measured externally, is to be not less than one quarter of the internal diameter of the cap.

Table 5 — Dimensions of caps

DN	$D$ mm	$T$ mm	$K$ mm	Conventional mass <sup>1)</sup> kg ≈
15	21,3	2	25	—
		3,2		0,04
		4		—
20	26,9	2	25	—
		3,2		0,07
		4		—
25	33,7	2,3	38	—
		3,2		0,10
		4,5		—
32	42,4	2,6	38	—
		3,6		0,14
		5		—
40	48,3	2,6	38	—
		3,6		0,17
		5		—
50	60,3	2,9	38	—
		4		0,24
		5,6		0,32
65	76,1	2,9	38	—
		5		0,39
		7,1		0,52
80	88,9	3,2	51	—
		5,6		0,67
		8		0,91
100	114,3	3,6	64	—
		6,3		1,2
		8,8		1,6
125	139,7	4	76	—
		6,3		1,8
		10		2,8
150	168,3	4,5	89	—
		7,1		2,9
		11		4,4
200	219,1	6,3	102	—
		8		5,0
		12,5		7,6

1) For information only.



Table 5 — Dimensions of caps (concluded)

DN	<i>D</i> mm	<i>T</i> mm	<i>K</i> mm	Conventional mass <sup>1)</sup> kg ≈
250	273	6,3 10	152	— 9,8
300	323,9	7,1 10	178	— 14
350	355,6	8 11	191	— 18
400	406,4	8,8 12,5	203	— 26
450	457	10	229	29
500	508	11	254	37
600	610	12,5	305	54
700	711		305	
800	813		305	
900	914		305	
1 000	1 016		305	

1) For information only.

#### 6.1.6 Stub ends

**Figure 6 — Stub ends**  
(Still under consideration)

**Table 6 — Dimensions of stub ends**  
(Still under consideration)

## 6.2 Tolerances

### 6.2.1 On dimensions

Table 7 — Tolerances on dimensions

Outside diameter mm	$D, D_1$ mm	$d, d_1$ mm	$T, T_1$ %	$F, H, L$ mm	$B$ mm	$C$ mm	$K$ mm
$D < 60,3$	+ 1,6 - 0,8	± 0,8	- 12,5	± 1,6	± 6,3	± 6,3	± 3,2
$60,3 < D < 114,3$	± 1,6	± 1,6					± 6,3
$114,3 < D < 219,1$	+ 2,4 - 1,6	± 1,6		± 6,3			
$219,1 < D < 457$	+ 4 - 3,2	± 3,2		± 2,4		± 9,5	± 6,3
$457 < D < 610$	+ 6,3 - 4,8	± 4,8		± 4,8		—	—
$610 < D < 1\ 016$	+ 6,3 - 4,8	± 4,8	—	—	—	—	± 9,5

### 6.2.2 On alignment

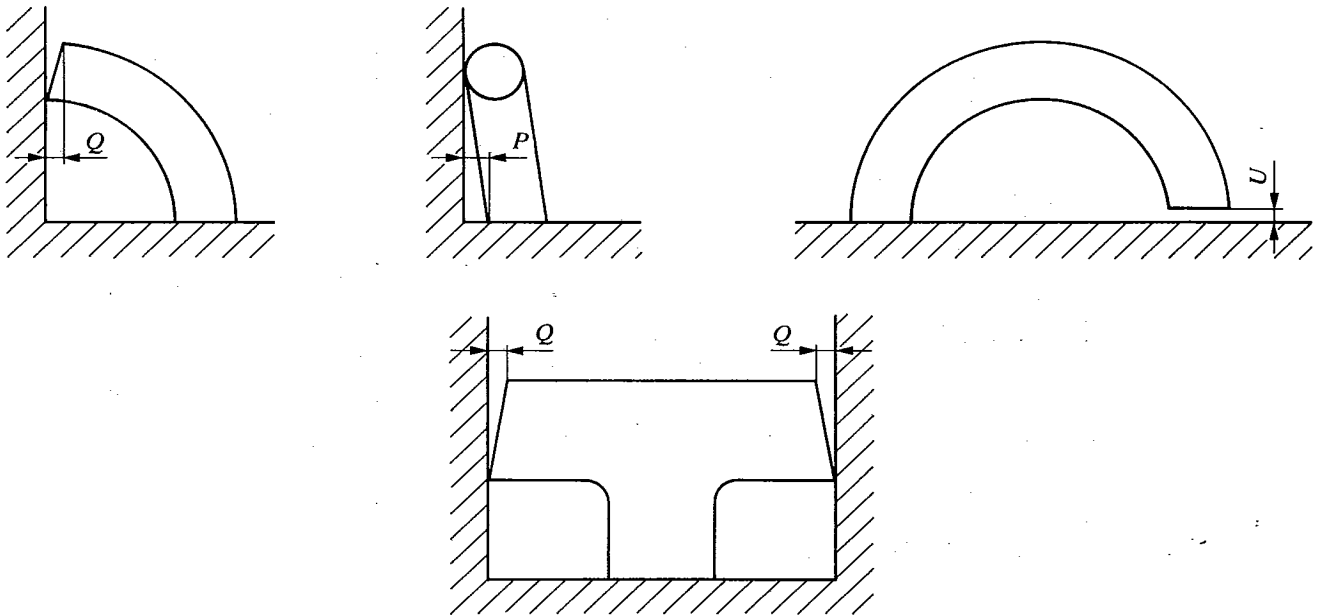

Figure 7 — Tolerances on alignment

Table 8 — Tolerances on alignment

Outside diameter mm	$P$ mm	$Q$ mm	$U$ mm
$D < 114,3$	1,6	0,8	± 0,8
$114,3 < D < 219,1$	3,2	1,6	
$219,1 < D < 323,9$	4,8	2,4	± 1,6
$323,9 < D < 406,4$	6,3	2,4	
$406,4 < D < 610$	9,5	3,2	
$610 < D < 711$	9,5	4,8	± 1,6
$711 < D$	12,7	4,8	

6.2.3 On the bevel

The ends of the accessories shall be cut square. For thicknesses exceeding 3,6 mm the ends shall be bevelled.

Table 9 — Shape and dimensions of the ends

Thickness mm	Ends	$\alpha$ degrees	$\beta$ degrees	$c$ mm	$f$ mm	$r$ mm	$r_1$ mm
$T < 3,6$		—	—	—	—	—	—
$3,6 < T < 20$		—	—	—	—	—	—
$T < 20$		$30 \begin{smallmatrix} + 5 \\ 0 \end{smallmatrix}$	$10 \pm 1$	$1,6 \pm 0,8$	19	$\approx 3$	—
							$\approx 6$

## 7 Heat treatment

### 7.1 Non-alloy steel fittings

Non-alloy steel fittings on which the final forming operation is completed between 640 and 940 °C need not be heat treated if cooled in still air.

For fittings finished above or below these temperature limits, the heat treatment for non-alloy steels detailed in the tables listed in 7.3 shall apply.

### 7.2 Alloy steel fittings

All alloy steel fittings shall be heat treated after the final forming operation. For each grade of material, the appropriate heat treatment specified in the tables in 7.3 shall apply.

### 7.3 Tables for heat treatment :

ISO 2604/2, Table 3;

ISO 2604/3, Table 3;

ISO 2604/4, Table 1.

## 8 Marking

The manufacturer shall mark on each place by painting, low

stress stamping or on a label,

- the trade mark or name;
- the outside diameter and thickness;
- the grade of steel;
- the number of this International Standard.

## 9 Testing

Normally acceptance tests are not required for fittings manufactured to the conditions of this International Standard.

By agreement between the purchaser and the manufacturer, tests may be specified in the enquiry and order.

## 10 Certificate

**10.1** When required by the purchaser, the manufacturer shall supply a certificate stating that the items supplied comply with this International Standard.

**10.2** This certificate shall comply with the requirements of 5.2.1 and 5.2.2 of ISO 404.