Rubber — Measurement of vulcanization characteristics with the oscillating disc curemeter

Caoutchouc — Détermination des caractéristiques de vulcanisation à l'aide du rhéomètre à disque oscillant



PDF disclaimer

This PDF file may contain embedded typefaces. In accordance with Adobe's licensing policy, this file may be printed or viewed but shall not be edited unless the typefaces which are embedded are licensed to and installed on the computer performing the editing. In downloading this file, parties accept therein the responsibility of not infringing Adobe's licensing policy. The ISO Central Secretariat accepts no liability in this area.

Adobe is a trademark of Adobe Systems Incorporated.

Details of the software products used to create this PDF file can be found in the General Info relative to the file; the PDF-creation parameters were optimized for printing. Every care has been taken to ensure that the file is suitable for use by ISO member bodies. In the unlikely event that a problem relating to it is found, please inform the Central Secretariat at the address given below.



COPYRIGHT PROTECTED DOCUMENT

© ISO 2008

All rights reserved. Unless otherwise specified, no part of this publication may be reproduced or utilized in any form or by any means, electronic or mechanical, including photocopying and microfilm, without permission in writing from either ISO at the address below or ISO's member body in the country of the requester.

ISO copyright office
Case postale 56 • CH-1211 Geneva 20
Tel. + 41 22 749 01 11
Fax + 41 22 749 09 47
E-mail copyright@iso.org
Web www.iso.org

Published in Switzerland

Contents

Page

Foreword.....	iv
1 Scope	1
2 Normative references	1
3 Terms and definitions.....	1
4 Principle.....	1
5 Apparatus	2
6 Calibration of torque transducer and recorder.....	4
7 Test piece	4
8 Curing temperature.....	4
9 Conditioning.....	4
10 Procedure	4
11 Expression of results	5
12 Test report	6

Foreword

ISO (the International Organization for Standardization) is a worldwide federation of national standards bodies (ISO member bodies). The work of preparing International Standards is normally carried out through ISO technical committees. Each member body interested in a subject for which a technical committee has been established has the right to be represented on that committee. International organizations, governmental and non-governmental, in liaison with ISO, also take part in the work. ISO collaborates closely with the International Electrotechnical Commission (IEC) on all matters of electrotechnical standardization.

International Standards are drafted in accordance with the rules given in the ISO/IEC Directives, Part 2.

The main task of technical committees is to prepare International Standards. Draft International Standards adopted by the technical committees are circulated to the member bodies for voting. Publication as an International Standard requires approval by at least 75 % of the member bodies casting a vote.

Attention is drawn to the possibility that some of the elements of this document may be the subject of patent rights. ISO shall not be held responsible for identifying any or all such patent rights.

ISO 3417 was prepared by Technical Committee ISO/TC 45, *Rubber and rubber products*, Subcommittee SC 2, *Testing and analysis*.

This third edition cancels and replaces the second edition (ISO 3417:1991), which has been technically revised.

Rubber — Measurement of vulcanization characteristics with the oscillating disc curemeter

WARNING — Persons using this International Standard should be familiar with normal laboratory practice. This standard does not purport to address all of the safety problems, if any, associated with its use. It is the responsibility of the user to establish appropriate safety and health practices and to ensure compliance with any national regulatory conditions.

CAUTION — Certain procedures specified in this International Standard may involve the use or generation of substances, or the generation of waste, that could constitute a local environmental hazard. Reference should be made to appropriate documentation on safe handling and disposal after use.

1 Scope

This International Standard specifies a method for determining selected vulcanization characteristics of a rubber compound by means of an oscillating disc curemeter. The use of the curemeter is described in ISO 6502.

2 Normative references

The following referenced documents are indispensable for the application of this document. For dated references, only the edition cited applies. For undated references, the latest edition of the reference document (including any amendments) applies.

ISO 6502, *Rubber — Guide to the use of curemeters*

3 Terms and definitions

For the purposes of this document, the terms and definitions given in ISO 6502 apply.

4 Principle

4.1 A test piece of rubber is contained in a sealed test cavity under an initial positive pressure and maintained at an elevated temperature. A biconical disc is embedded in the test piece and is oscillated through a small rotary amplitude. This action exerts a shear strain on the test piece, and the torque required to oscillate the disc depends on the stiffness (shear modulus) of the rubber. The torque is recorded autographically as a function of time.

Direct proportionality between torque and stiffness cannot be expected under all test conditions because — particularly in higher torque ranges — elastic deformation of the disc shaft and driving device have to be taken into account. Moreover, in cases of small amplitudes of deformation, the strain can be expected to have a considerable elastic component. For routine control purposes, however, corrections are not necessary.

4.2 The stiffness of the rubber test piece increases as vulcanization proceeds. The curve is complete when the recorded torque rises either to an equilibrium value or to a maximum value (see Figure 1). If the torque continues to increase, vulcanization is considered to be complete after a given time. The time required to

obtain a vulcanization curve is a function of the test temperature and the characteristics of the rubber compound.

4.3 The following parameters can be measured from the recorded curve of torque as a function of time, i.e. $M = f(t)$ (see Figure 1):

M_L	minimum torque;
M_{HF}	plateau torque;
M_{HR}	maximum torque (reverting curve);
M_H	highest torque value attained in a curve where no plateau or maximum value is reached after a specified time;
t_{sx}	time to incipient cure (scorch time);
$t_c(y)$	time to a given percentage of the highest measured torque;
$t'_c(y)$	time from the minimum torque to a given percentage of full cure;
$\frac{100}{t_c(y) - t_{sx}}$	cure rate index (average slope of curve, calculated as indicated by the formula).

The minimum torque M_L depends on the stiffness and the viscosity at low shear rate of the unvulcanized compound.

The highest torque (M_{HF} , M_{HR} or M_H) is a measure of the stiffness of the vulcanized rubber at the temperature of test.

The time to incipient cure t_{sx} is a measure of processing safety.

The times $t_c(y)$ and $t'_c(y)$ and the corresponding torques give information on the progress of vulcanization. The optimum time is often given by $t'_c(90)$.

5 Apparatus

5.1 Curemeter

The curemeter consists of a biconical disc in a temperature-controlled die cavity. The shaft of the disc is secured in a drive shaft and oscillated through a small rotary amplitude (see Figure 2).

The torque applied to the disc represents the resistance of the rubber test piece to deformation and is recorded autographically to yield a curve of torque versus time.

5.2 Die cavity

5.2.1 The dies shall be manufactured from a non-deforming tool steel having a minimum Rockwell hardness of 50 HRC.

The geometry of the dies is shown in Figures 3 and 4. Suitable means shall be employed, by the design of the dies or otherwise, to apply pressure on the test piece throughout the test in order to minimize slippage between the disc and the rubber. Holes shall be drilled in both the upper and lower dies at the locations shown in Figures 3 and 4 to enable temperature sensors to be inserted. The surfaces of the die cavity shall contain rectangular-shaped grooves located at 20° intervals to minimize slippage. The lower die dimensions shall be as given in Figure 3. The upper die shall contain identically shaped grooves. The dimensions of the upper die shall be as given in Figure 4.

5.2.2 The lower die shall have a hole in the centre to allow the insertion of disc stem. A suitable low constant friction seal shall be fitted in this hole to prevent material from leaking from the die cavity.

5.3 Die closure

The dies shall be closed, and held closed during the test, by a pneumatic cylinder exerting a force of $11,0 \text{ kN} \pm 0,5 \text{ kN}$.

5.4 Disc

The biconical disc shall be fabricated from a non-deforming tool steel having a minimum Rockwell hardness of 50 HRC. The disc is shown in Figure 5, and the critical dimensions are given in Table 1.

5.5 Disc oscillation

The frequency of the rotary oscillation of the disc shall be $1,7 \text{ Hz} \pm 0,1 \text{ Hz}$ except for particular purposes when other frequencies in the range 0,05 Hz to 2 Hz may be used. The maximum angular displacement of the disc shall be $1,00^\circ \pm 0,02^\circ$ about its central position (total amplitude 2°) when the die cavity is empty. If a torque is acting on the disc, the resulting decrease in the angle of oscillation with increasing torque shall be a linear function having a slope within the limits of $0,05^\circ/\text{N}\cdot\text{m} \pm 0,002^\circ/\text{N}\cdot\text{m}$.

Suitable devices shall be provided to verify both the initial amplitude of oscillation and the decrease in amplitude with applied torque.

Other amplitudes may be used when specified for particular purposes. With different frequencies or amplitudes, different results will be obtained.

NOTE An initial amplitude of oscillation of 3° can be used in cases where danger of slippage between test piece and die cavity or disc can be excluded (first of all by regular cleaning of the rotor, see 10.2.3). A higher sensitivity in testing may be obtained at this amplitude, which may be useful in production quality control.

5.6 Torque-measuring system

5.6.1 Measurement

A device which produces a signal that is directly proportional to the torque required to turn the disc shall be used to measure the torque acting on the disc.

5.6.2 Recording

A recorder with a paper feed shall be used to record the signal from the torque-measuring device. The recorder shall have a speed of response for full-scale deflection on the torque scale of 1 s or less. The torque shall be recorded with an accuracy of $\pm 0,5 \%$ of the torque range. Three torque ranges from 0 N·m to 2,5 N·m, 0 N·m to 5 N·m and 0 N·m to 10 N·m shall be provided.

Although the procedure is written for a pen recorder with a paper feed, automatic data acquisition and processing equipment may also be used.

5.7 Temperature measurement

5.7.1 The temperature-measuring systems shall enable the temperature of the dies to be measured to within $\pm 0,1^\circ\text{C}$ over the range 100°C to 200°C . Calibrated thermocouples, or other suitable temperature sensors, inserted in the dies, shall be used for periodically checking the die temperatures.

5.7.2 The dies shall be mounted in electrically heated aluminium platens. Temperature controllers shall be used to control the temperature of each platen to within $\pm 0,3^\circ\text{C}$ at steady state. After insertion of a test piece at $23^\circ\text{C} \pm 5^\circ\text{C}$, the temperature of the dies shall recover to within $0,3^\circ\text{C}$ of the test temperature within 3 min.

6 Calibration of torque transducer and recorder

6.1 Provision shall be made for electronic verification of the recorder and torque transducer. One way of doing this is calibration by means of a resistor incorporated in the torque-measuring circuit and which simulates an applied torque of specified value.

6.2 The torque-measuring system shall be calibrated by means of masses or by a standard torque system such as a calibrated torsion spring.

6.3 In order to detect differences between curemeters or changes with use in a single curemeter, tests on reference compounds are useful. The reference compound shall have a shear modulus equal to or greater than the production compounds being tested, and it shall be homogeneous and stable for several weeks. Several tests shall be made on calibrated curemeter(s) in good condition and, from each curve, parameters such as M_H , M_L or t_C' shall be determined. Each set of values obtained for each parameter shall be used to define a confidence interval at a chosen statistical confidence level (95 % or 99 %).

Small changes with use or small differences between curemeters shall not be compensated for if the material parameters measured (M_H , M_L or t_C' , for instance) are within the confidence intervals. In such a case, the differences observed are not statistically significant.

The cause of large deviations, i.e. the cause of statistically significant variations detected when one of the parameters is no more within its confidence interval, shall be determined and necessary repairs or maintenance performed.

7 Test piece

A test piece approximately 30 mm in diameter and 12,5 mm in thickness or of the equivalent volume shall be used for each test. Preferably, the test piece should be cut from a previously sheeted sample, which shall be as free from air as practical. A total volume of 8 cm³ for the test piece is considered optimum.

NOTE Suitable test piece size is assured if a small amount of compound is allowed to extrude between the edges of the dies. Oversized test pieces cool the cavity excessively during the early part of the test cycle and invalidate the test.

8 Curing temperature

The curing temperature is determined by the nature of the rubber compound or the application, but will normally be in the range 100 °C to 200 °C. The tolerances on the curing temperature shall be $\pm 0,3$ °C.

9 Conditioning

The test piece shall be conditioned at $23 \text{ °C} \pm 5 \text{ °C}$ for a minimum of 3 h before testing.

10 Procedure

10.1 Preparation for test

Bring the temperature of both dies (see 5.2) to the curing temperature, with the disc (5.4) in place and the die cavity in the closed position. With the disc in place and the dies closed, adjust the recorder pen to the zero-torque line on the chart. Position the pen at the zero-time position on the chart. Calibrate the recorder if needed (see 6.1) and select the correct torque range (see 5.6.2).

10.2 Loading the curemeter

10.2.1 Open the dies, place the test piece on top of the disc, and close the dies within 5 s. When testing sticky compounds, insert some suitable thin-film material below the rotor and above the test piece to keep the compound from sticking to the dies.

10.2.2 Time shall be counted from the instant the dies are closed. The disc may be oscillating (see 5.5) at zero time or started not later than 1 min after the dies are closed. The curve is complete when the recorded torque rises either to an equilibrium value or to a maximum value. If the torque continues to increase, vulcanization is considered to be complete after a given time.

10.2.3 A deposit of material from the rubber compounds under test may build up on the disc and dies. This may affect the final torque values. It is suggested that reference compounds be tested daily to detect this occurrence. If such contamination develops, it may be removed by very light blasting with a mild abrasive. Extreme care shall be used in this operation to retain sharpness of serrations and not change dimensions. Ultrasonic cleaning or cleaning with hot solvents or non-corrosive cleaning solutions may also remove the deposit. If solvent or solution cleaning is used, the first two sets of results after cleaning shall be rejected.

11 Expression of results

11.1 General

The applicable values of those indicated in 11.2 to 11.5 shall be taken from the cure curve.

11.2 Torque values

- M_L minimum torque, in newton metres;
- M_{HF} plateau torque, in newton metres;
- M_{HR} maximum torque (reverting curve), in newton metres;
- M_H highest torque value attained, in newton metres, in a curve where no plateau or maximum value is obtained after the specified time.

11.3 Time values

- t_{sx} time, in minutes, to an increase of x tenths of a unit of torque above M_L (see 11.4 and 11.5);
- $t_c(y)$ cure time, in minutes, to y % of full torque development (see 11.5);
- $t_c'(y)$ cure time, in minutes, for torque to increase from the minimum torque M_L to $M_L + 0,01y(M_H - M_L)$ (see 11.4).

11.4 Times to different percentages of full cure

Unless otherwise specified, it is recommended that the following specific parameters be used:

- t_{s1} time, in minutes, for torque to increase to 0,1 N·m above M_L ;
- $t_c'(50)$ time, in minutes, for torque to reach $M_L + 0,5(M_H - M_L)$;
- $t_c'(90)$ time, in minutes, for torque to reach $M_L + 0,9(M_H - M_L)$.

If an amplitude of 3° is used instead of the standard 1°, t_{s2} shall be used in place of t_{s1} ; i.e. the time, in minutes, for the torque to increase to 0,2 N·m above M_L .

11.5 Cure rate index

$100/[t_c(y) - t_{sx}]$ parameter representative of the average slope of the cure rate curve in the steep region.

12 Test report

The test report shall include the following information:

- a) sample details:
 - 1) a full description of the sample and its origin,
 - 2) details of the compound tested;
- b) test method:
 - 1) a reference to this International Standard,
 - 2) details of the curemeter used;
- c) test details:
 - 1) the nominal amplitude of oscillation, reported as half the total displacement, i.e. 1° for a total displacement of 2°,
 - 2) the frequency of oscillation, in hertz, if other than 1,7 Hz (see 5.5),
 - 3) the torque range selected, in newton metres,
 - 4) the paper feed speed of the recorder, in millimetres per minute,
 - 5) the heating-up time, in minutes (see 5.7.2.),
 - 6) the curing temperature, in degrees Celsius;
- d) test results:
 - 1) the type of vulcanization curve obtained (see Figure 1),
 - 2) the test results read from the curve;
- e) the date of the test.

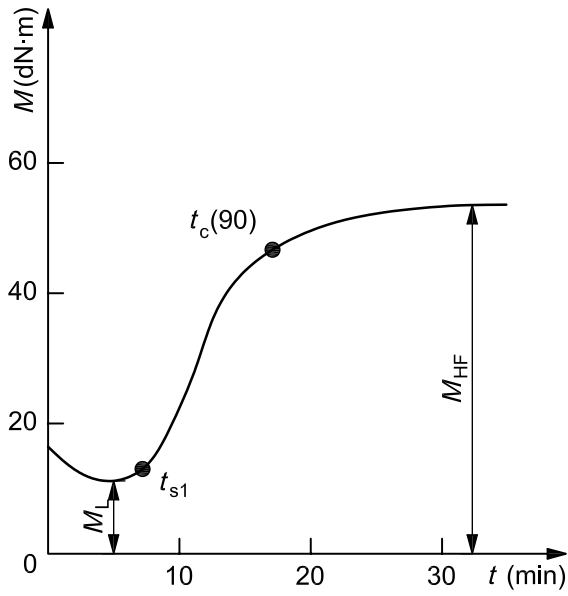

a) Cure to equilibrium

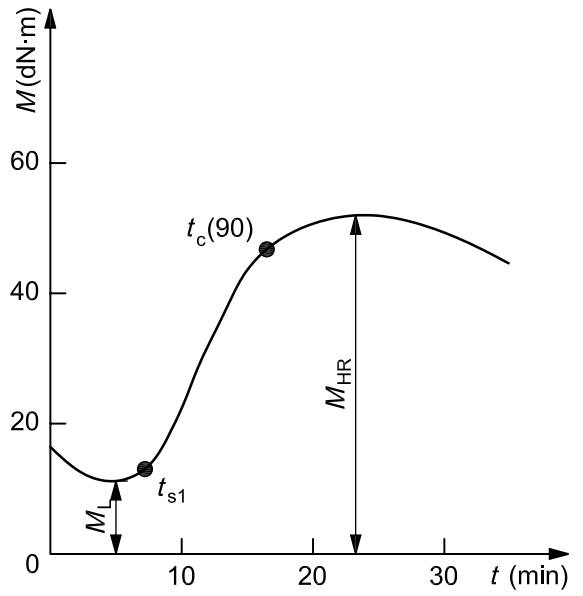

b) Cure to a maximum torque with reversion

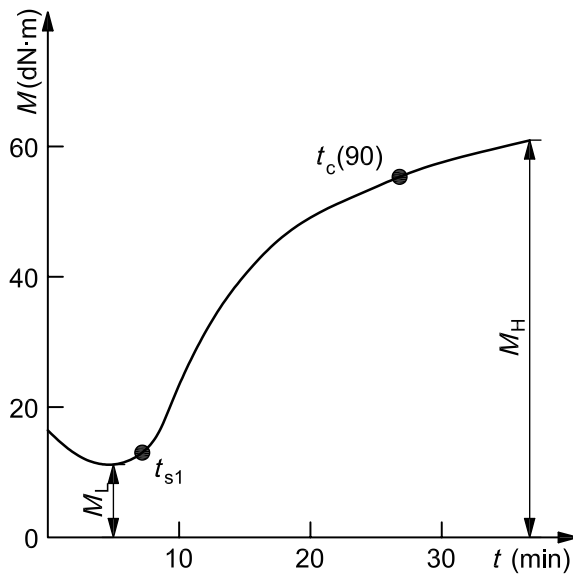

c) Cure to no equilibrium in maximum torque

Figure 1 — Types of vulcanization curve

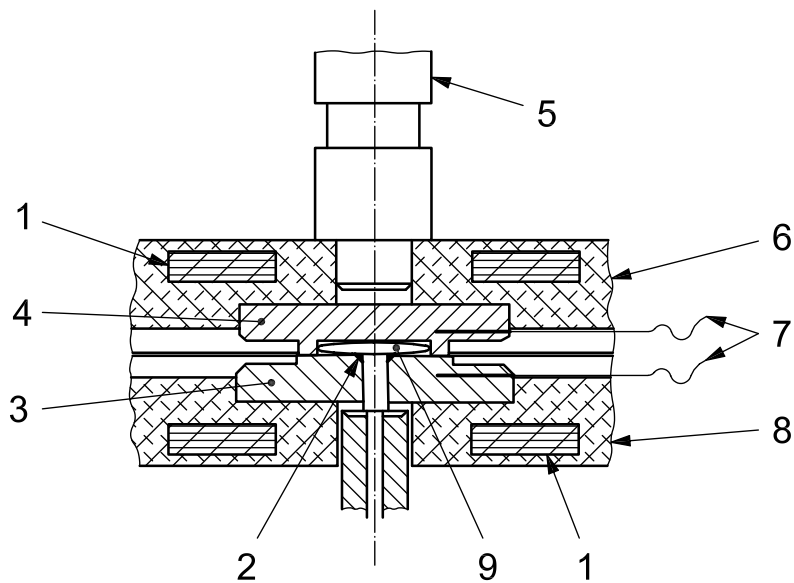

Key

- | | | | |
|---|--------------|---|--------------------------------|
| 1 | heater | 6 | upper platen |
| 2 | seal | 7 | calibrated temperature sensors |
| 3 | lower die | 8 | lower platen |
| 4 | upper die | 9 | biconical disc |
| 5 | cylinder rod | | |

Figure 2 — Curemeter assembly

Dimensions in millimetres

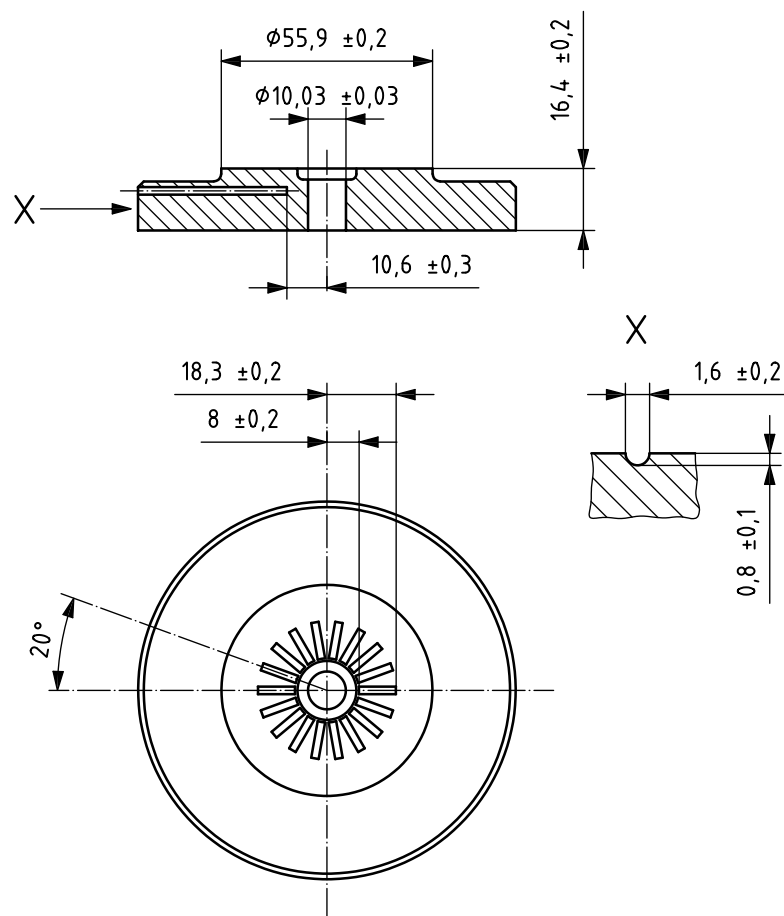

Figure 3 — Lower die

Dimensions in millimetres

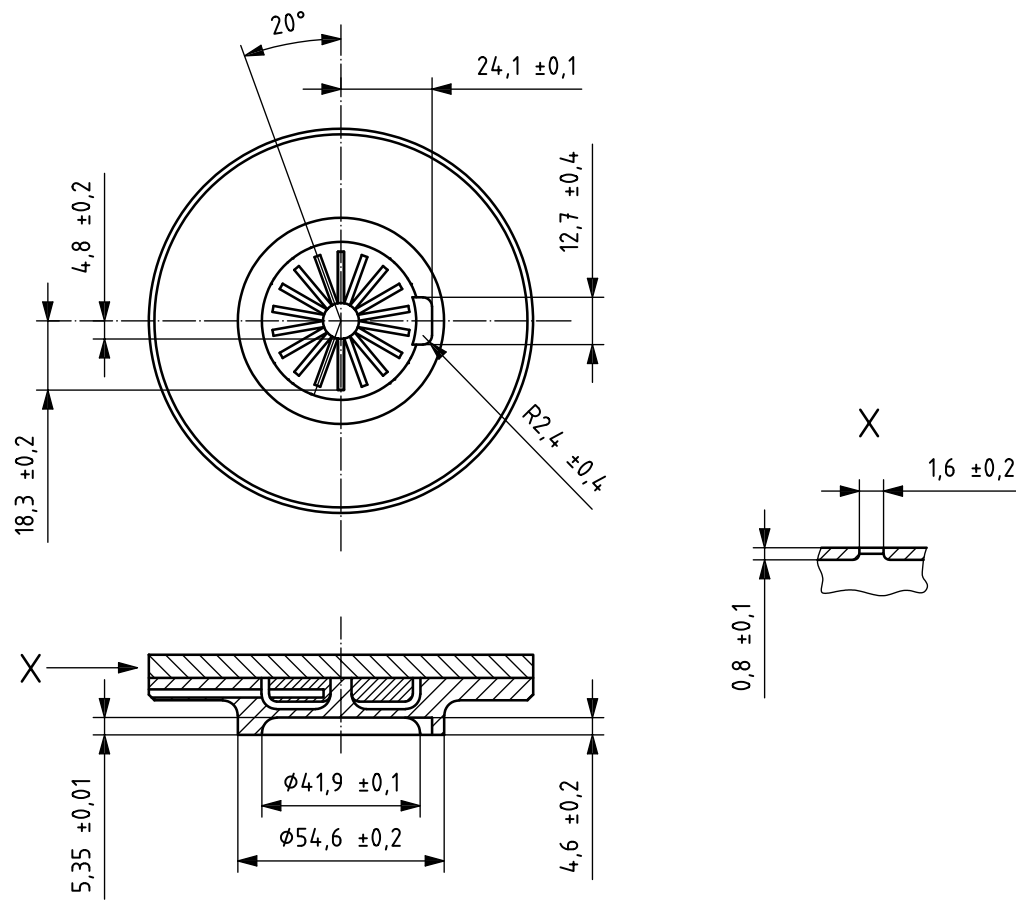
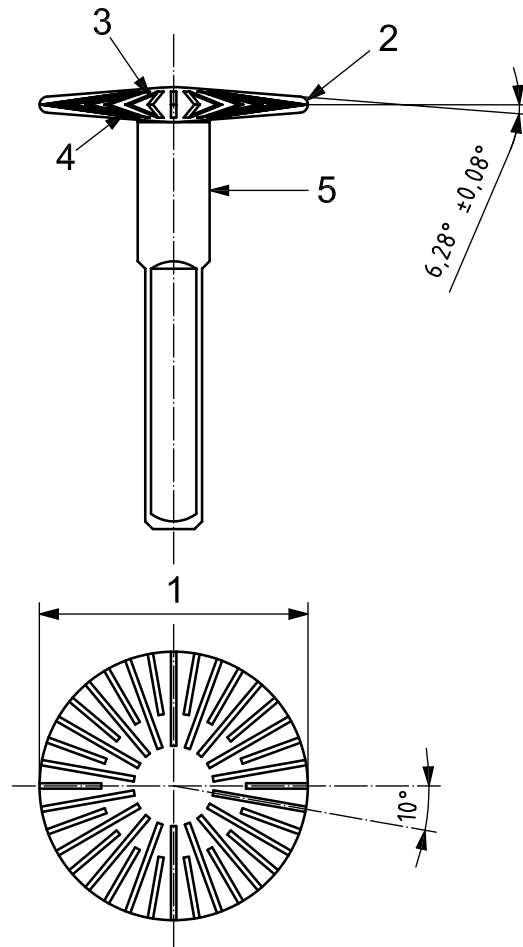

Figure 4 — Upper die



Key

See Table 1.

Figure 5 — Biconical disc

Table 1 — Disc dimensions

Dimensions in millimetres

Ref. No.	Dimension		Tolerance
1	Diameter	35,55	± 0,01
2	Radius	0,80	± 0,03
3 ^a	Groove width	0,80	± 0,05
	Groove depth	0,8	± 0,1
	Groove lengths	7,5 min. 12,5 min.	
4	Groove width	0,80	± 0,05
	Groove depth	0,8	± 0,1
	Groove lengths	7,5 min. 9,5 min.	
5	Diameter	9,51	± 0,01
	Length of the circular part of the disc shaft	20,0	± 0,5
	Length of the square part of the disc shaft	35,0	± 0,5

^a The grooves on the top and bottom surfaces shall be staggered by 5°.

