

INTERNATIONAL STANDARD

ISO
3382-3

First edition
2012-01-15

Acoustics — Measurement of room acoustic parameters —

Part 3: Open plan offices

*Acoustique — Mesurage des paramètres acoustiques des salles —
Partie 3: Bureaux ouverts*



Reference number
ISO 3382-3:2012(E)

© ISO 2012

ISO 3382-3:2012(E)



COPYRIGHT PROTECTED DOCUMENT

© ISO 2012

All rights reserved. Unless otherwise specified, no part of this publication may be reproduced or utilized in any form or by any means, electronic or mechanical, including photocopying and microfilm, without permission in writing from either ISO at the address below or ISO's member body in the country of the requester.

ISO copyright office
Case postale 56 • CH-1211 Geneva 20
Tel. + 41 22 749 01 11
Fax + 41 22 749 09 47
E-mail copyright@iso.org
Web www.iso.org

Published in Switzerland

Contents	Page
Foreword	iv
Introduction	v
1 Scope	1
2 Normative references	1
3 Terms and definitions	1
4 Single number quantities	2
5 Measurement conditions	3
5.1 Equipment	3
5.2 Measurement procedure	3
6 Determination of single number quantities	6
6.1 Sound power spectrum of normal speech	6
6.2 Spatial decay rate of A-weighted sound pressure level of speech	6
6.3 Distraction and privacy distances	9
6.4 Background noise	9
7 Test report	9
Annex A (informative) Examples of target values for evaluation of measurement data	11
Annex B (informative) Relation between speech transmission index and work performance	12
Bibliography	14

ISO 3382-3:2012(E)

Foreword

ISO (the International Organization for Standardization) is a worldwide federation of national standards bodies (ISO member bodies). The work of preparing International Standards is normally carried out through ISO technical committees. Each member body interested in a subject for which a technical committee has been established has the right to be represented on that committee. International organizations, governmental and non-governmental, in liaison with ISO, also take part in the work. ISO collaborates closely with the International Electrotechnical Commission (IEC) on all matters of electrotechnical standardization.

International Standards are drafted in accordance with the rules given in the ISO/IEC Directives, Part 2.

The main task of technical committees is to prepare International Standards. Draft International Standards adopted by the technical committees are circulated to the member bodies for voting. Publication as an International Standard requires approval by at least 75 % of the member bodies casting a vote.

Attention is drawn to the possibility that some of the elements of this document may be the subject of patent rights. ISO shall not be held responsible for identifying any or all such patent rights.

ISO 3382-3 was prepared by Technical Committee ISO/TC 43, *Acoustics*, Subcommittee SC 2, *Building acoustics*.

ISO 3382 consists of the following parts, under the general title *Acoustics — Measurement of room acoustic parameters*:

- *Part 1: Performance spaces*
- *Part 2: Reverberation time in ordinary rooms*
- *Part 3: Open plan offices*

Introduction

The phrase “open plan offices” in the context of this part of ISO 3382 covers offices and similar spaces where a large number of people can work, have a conversation, or concentrate independently in well-defined work stations. In open plan offices, the occupants are affected by activities surrounding them. Insufficient acoustic conditions lead to distraction and a lack of speech privacy. Distraction weakens the ability to concentrate and reduces productivity, especially in tasks requiring cognitive resources. Low speech privacy prevents confidential or partly confidential conversations. Speech can be intrusive for the listener, whereas for the speaker, it can be desirable to avoid involuntary spread of speech of a private nature.

The design of open plan spaces includes careful consideration of the layout of the workstations and mutual arrangement of teams or workgroups. Other factors affecting the acoustical performance of open plan spaces are sound absorption, height of screens and storage units, background noise, degree of workstation enclosure, distance between workstations, and room dimensions. The reverberation time of a room used to be regarded as the predominant indicator of its acoustical properties. However, there is evidence that other types of measurements such as rate of spatial decay of sound pressure levels, speech transmission index and background noise levels are needed for a more complete evaluation. If reverberation time is considered relevant, it should be measured in accordance with ISO 3382-2.

This part of ISO 3382 specifies a measurement method which results in single number quantities indicating the general acoustical performance of open plan offices. The principal aim is good speech privacy between workstations. The measurement method and resulting single number quantities correspond well with perceived acoustic conditions of the worker.

Furniture strongly affects acoustic conditions. Therefore, the measurements are performed only when the room is completely finished, including furniture. Measurement in an unfurnished room does not describe the perceived acoustical conditions. It is also important that the measurements are carried out when people are absent, but with the normal daytime background noise, whether it is caused by ventilation, traffic noise or an artificial masking sound system. If people are present, the background noise level varies strongly with time and the determination of reliable results becomes impossible.

The single number quantities are designed to represent the situation where a single person is talking and the rest are silent. Therefore, the measurements are made by using a single loudspeaker. If many people speak simultaneously, the masking is increased and the degree of distraction gets weaker (see Reference [10]). Therefore, the results describe the most distracting situation. However, this part of ISO 3382 can be used to determine the room acoustic quality of, for example, call centres where many speakers are active continuously. In such cases, the sound environment caused by many simultaneous speakers may cause a positive speech masking effect and the results of this part of ISO 3382 may underestimate the perceived speech privacy.

Acoustics — Measurement of room acoustic parameters —

Part 3: Open plan offices

1 Scope

This part of ISO 3382 specifies methods for the measurement of room acoustic properties in open plan offices with furnishing. It specifies measurement procedures, the apparatus needed, the coverage required, the method for evaluating the data, and the presentation of the test report.

The measurement results can be used to evaluate room acoustic properties in open plan offices. This part of ISO 3382 is intended for medium and large size open plan offices.

2 Normative references

The following referenced documents are indispensable for the application of this document. For dated references, only the edition cited applies. For undated references, the latest edition of the referenced document (including any amendments) applies.

ISO 3382-1, *Acoustics — Measurement of room acoustic parameters — Part 1: Performance spaces*

ISO 3740, *Acoustics — Determination of sound power levels of noise sources — Guidelines for the use of basic standards*

ISO 3744, *Acoustics — Determination of sound power levels and sound energy levels of noise sources using sound pressure — Engineering methods for an essentially free field over a reflecting plane*

ISO 14257, *Acoustics — Measurement and parametric description of spatial sound distribution curves in workrooms for evaluation of their acoustical performance*

ISO 16032, *Acoustics — Measurement of sound pressure level from service equipment in buildings — Engineering method*

IEC 61672-1, *Electroacoustics — Sound level meters — Part 1: Specifications*

IEC 61260, *Electroacoustics — Octave-band and fractional-octave-band filters*

IEC 60268-16:2011, *Sound system equipment — Part 16: Objective rating of speech intelligibility by speech transmission index*

3 Terms and definitions

For the purposes of this document, the following terms and definitions apply.

3.1

spatial sound distribution of the A-weighted sound pressure level of speech

curve which shows how the A-weighted sound pressure level decreases as a function of the distance from the sound source emitting noise with the sound power spectrum of normal speech

ISO 3382-3:2012(E)

3.2 spatial decay rate of speech

$D_{2,S}$

rate of spatial decay of A-weighted sound pressure level of speech per distance doubling

NOTE This definition is an application of DL_2 defined in ISO 14257, but using the spectrum of normal speech and A-weighting over the whole frequency range. The spatial decay is not determined for individual octave bands.

3.3 A-weighted sound pressure level of speech at a distance of 4 m

$L_{p,A,S,4\text{ m}}$

nominal A-weighted sound pressure level of normal speech at a distance of 4,0 m from the sound source

NOTE The measurement position does not need to be located at this distance from the sound source. $L_{p,A,S,4\text{ m}}$ is obtained using a linear regression line from the spatial sound distribution of the A-weighted sound pressure level (SPL) of speech.

3.4 speech transmission index

STI

physical quantity representing the transmission quality of speech with respect to intelligibility

[IEC 60268-16:2011]

3.5 spatial sound distribution of the speech transmission index

curve which shows how the speech transmission index decreases from a reference sound source when distance increases

3.6 distraction distance

r_D

distance from speaker where the speech transmission index falls below 0,50

NOTE 1 Distraction distance is expressed in metres.

NOTE 2 Above the distraction distance, concentration and privacy start to improve rapidly (see References [8][14]).

3.7 privacy distance

r_P

distance from speaker where the speech transmission index falls below 0,20

NOTE 1 Privacy distance is expressed in metres.

NOTE 2 Above the privacy distance, concentration and privacy are experienced very much the same as between separate office rooms (see References [8][14]). STI values less than 0,20 are difficult to achieve in offices with poor speech privacy or small volume.

3.8 background noise level

$L_{p,B}$

sound pressure level in octave bands present at the workstation during working hours with people absent

NOTE Background noise here means all such continuous sounds, which are not caused by people, e.g. heating, ventilation and air conditioning (HVAC) devices, environmental traffic noise, office equipment or a sound-masking system.

4 Single number quantities

The sound pressure levels and STI shall be measured in octave bands from 125 Hz to 8 000 Hz. STI shall be determined in accordance with the full method specified in IEC 60268-16.

The measurement data shall be converted into four simple single number quantities to facilitate the use in acoustic design and to enable the future establishment of simple target values. The single number quantities that are determined are:

- distraction distance, r_D ;
- spatial decay rate of A-weighted SPL of speech, $D_{2,S}$;
- A-weighted SPL of speech at 4 m, $L_{p,A,S,4\text{ m}}$;
- average A-weighted background noise level, $L_{p,A,B}$.

In addition to these, STI in the nearest workstation and the privacy distance, r_P , may also be determined.

5 Measurement conditions

5.1 Equipment

5.1.1 Sound source. In all measurements an omnidirectional sound source producing pink noise shall be used. Alternatively, it is also possible to use deterministic signals that have a pink spectrum like maximum-length sequence (MLS) or sweeps to measure the impulse response and derive the results from that (see Reference [13]).

An omnidirectional sound source is used since people in an open plan office do not continuously speak in any fixed direction. The requirements given in ISO 3382-1 for the omnidirectional sound source shall be fulfilled for measurements to be in accordance with this part of ISO 3382. Verification of the sound power of the source is performed as in ISO 3382-1, with the sound source positioned at the height of 1,2 m.

5.1.2 Microphone. Sound pressure levels in each octave band and at each microphone position shall be measured using a sound level meter meeting the requirements of IEC 61672-1, class 1. The microphone shall be omnidirectional (taking into account any supplementary equipment connected to it). Octave-band filters shall comply with IEC 61260.

If the signal is recorded (e.g. by using analogue or digital recorders) for off-line processing, it shall be ensured that the instrumentation as a whole complies with the above-mentioned requirements.

5.2 Measurement procedure

5.2.1 Measurement conditions

Measurements in accordance with this part of ISO 3382 shall be made in furnished rooms, but without the presence of people, except the persons needed to carry out the measurements.

The background noise level is measured and applied for the determination of the STI value. The HVAC devices and other noise sources shall operate on the same power as during typical working hours. If the sources operate at reduced power, the STI values are too high, leading to overestimation of r_D and r_P . If the office is equipped with a sound-masking system, it shall be switched on during the measurement.

Measurements in accordance with this part of ISO 3382 have to be carried out when people are absent. Thus the noise from people talking in the room is not included in the measured background noise level. It is recognized that noise from people talking in the open plan office can sometimes cause a positive masking effect (see Reference [10]). In such cases, the actual distraction distance and privacy distance are shorter than the measured r_D and r_P , respectively. The evaluation of the acoustic conditions with people talking is not within the scope of this part of ISO 3382.

5.2.2 Measurement positions

It is recommended that measurements be carried out along a line which crosses over workstations, as shown in Figure 1. The preferred number of successive measurement positions in the line is 6 to 10; the minimum

ISO 3382-3:2012(E)

number is 4. The first measurement position shall be located at the nearest workstation on the line. The distance to the most remote measurement position depends on the size of the room; however, only positions within the range 2 m to 16 m are used for the determination of $D_{2,S}$; see 6.2.

NOTE The measurement positions need not be on a straight line; see Figure 1.

Open plan offices consist very often of two or more zones where the ceiling materials are of different types or the furniture design differs significantly. Then the measurements should preferably be made in each zone. Single number quantities are calculated for each zone separately. If the measurement line crosses zones, the spatial distribution curves can have different slopes along the line.

The measurements shall be carried out using source and microphone positions in workstations in the position of the person's head. The positions of loudspeaker and microphone shall be at least 0,5 m from tables and at least 2,0 m from walls and other reflecting surfaces. At least two sound source positions shall be used. If only one line of measurement positions is possible, measurements shall be made with two source positions in opposite directions on the measurement line.

The loudspeaker shall be placed at the height of 1,2 m above the floor.

The microphone shall be placed at 1,2 m above the floor. Standing working positions are not applicable for this part of ISO 3382.

5.2.3 Measurement quantities

At every measurement point, four measurements are made:

- a) sound pressure level in octave bands of pink noise, $L_{p,Ls}$;
- b) STI;
- c) background noise level in octave bands, $L_{p,B}$;
- d) distance to the sound source, r .

Sound pressure level of pink noise and background noise level are measured in octave bands in the frequency range 125 Hz to 8 000 Hz in every measurement position. The integration time should be at least 10 s.

NOTE Integration times longer than 10 s are needed for non-stationary noise, e.g. traffic noise.

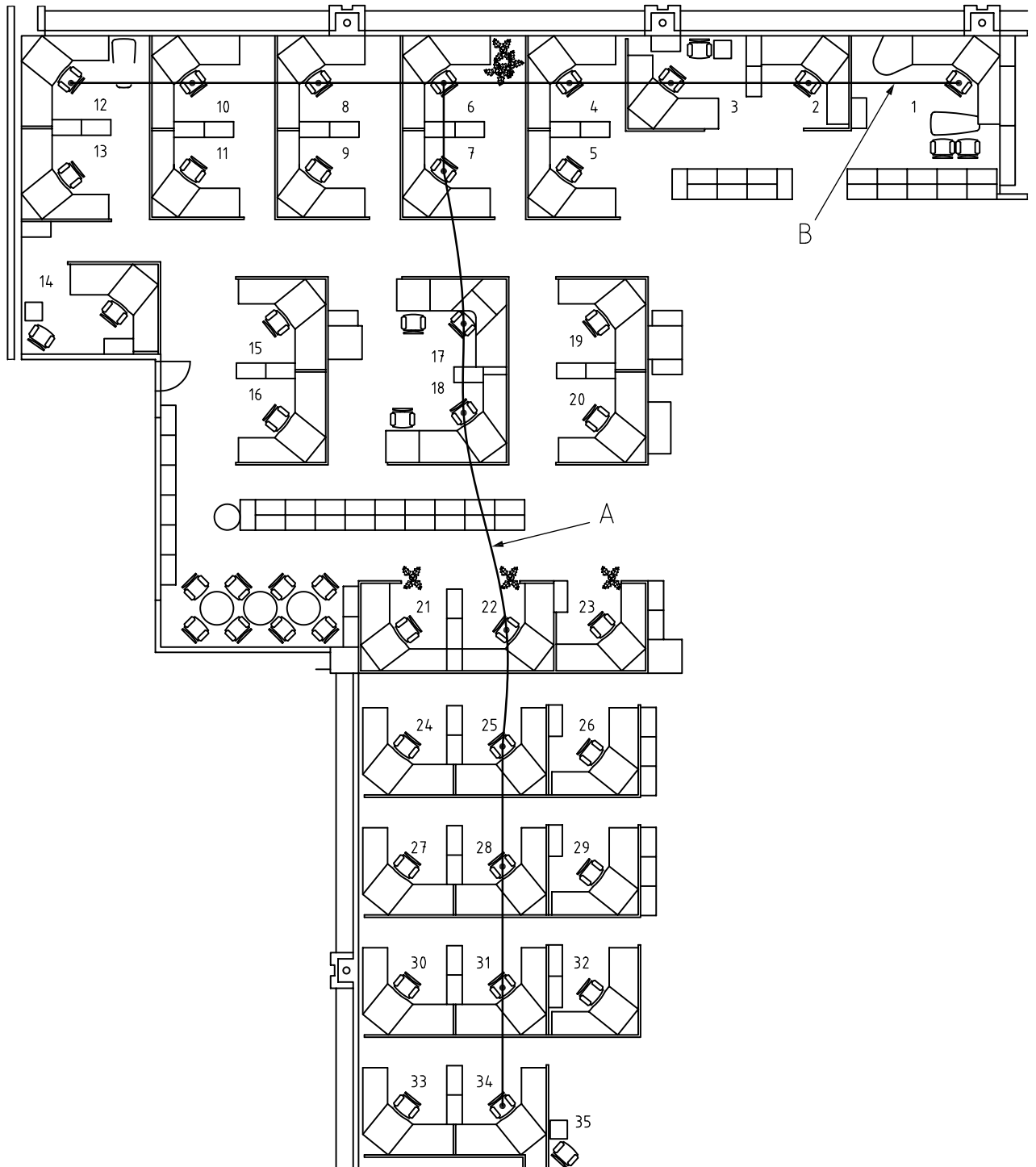

Key

- A non-straight measurement path
- B straight measurement path

Figure 1 — Example of a straight and a non-straight measurement path in an open plan office

ISO 3382-3:2012(E)

6 Determination of single number quantities

6.1 Sound power spectrum of normal speech

In this part of ISO 3382, the sound power spectrum of normal speech is used. The octave band values represent normal effort unisex speech (average of female and male speech). The octave band sound pressure levels at a distance of 1,0 m from the acoustic centre of the sound source in the free field ($L_{p,S,1\text{ m}}$) are presented in Table 1. The resulting A-weighted sound pressure level is 57,4 dB. Since an omnidirectional source is preferred for the measurements, the sound pressure levels represent the average sound radiation in all directions from the source.

Table 1 — The linear sound pressure levels of speech at a distance of 1 m in free field from the speaker and the A-weighting of octave bands

Band No. <i>i</i>	Frequency Hz	Sound power level $L_{W,S}$ dB re 1 pW	Sound pressure level $L_{p,S,1\text{ m}}$		A-weighting <i>A</i> dB
			Directional source dB re 20 µPa	Omnidirectional source dB re 20 µPa	
1	125	60,9	51,2	49,9	-16,1
2	250	65,3	57,2	54,3	-8,6
3	500	69,0	59,8	58,0	-3,2
4	1 000	63,0	53,5	52,0	0,0
5	2 000	55,8	48,8	44,8	1,2
6	4 000	49,8	43,8	38,8	1,0
7	8 000	44,5	38,6	33,5	-1,1
	A-weighted	68,4	59,5	57,4	

NOTE The spectrum in Table 1 is based on ANSI S 3.5-1997 (R 2007)^[5]. The averaged data for male and female speakers and for normal voice effort are from Reference [16]. As an omnidirectional sound source is preferred here, the sound power levels in octave bands have been calculated from the sound pressure levels on axis for a directional source, taking the directional characteristics into account. The directivity data are also from Reference [16].

6.2 Spatial decay rate of A-weighted sound pressure level of speech

The sound power level of the loudspeaker should be sufficiently high in each octave band so that the sound pressure level exceeds the background noise level by 6 dB at the most distant measurement point. The sound power level of the omnidirectional loudspeaker, $L_{W,LS}$, is determined using a measurement standard having at least engineering grade accuracy. Consult the overview of appropriate methods given in ISO 3740.

NOTE Appropriate methods are ISO 3741^[1], ISO 3743-1^[2], ISO 3743-2^[3], ISO 3744 or ISO 3745^[4].

This calibrated output of pink noise is used when spatial sound distribution of the A-weighted SPL of speech is determined in the open plan office. The sound pressure level at a distance of 1 m from the acoustic centre of the loudspeaker in a free field, $L_{p,LS,1\text{ m}}$, in decibels, is then

$$L_{p,LS,1\text{ m},i} = L_{W,LS,i} + 10 \lg \frac{1}{4\pi \times 1,0^2} \approx L_{W,LS,i} - 11 \text{ dB} \quad (1)$$

where

$L_{W,LS,i}$ is the sound power level of the loudspeaker in octave bands;

i denotes the octave band.

In an open plan space, the loudspeaker is placed in a selected source position and the sound pressure level, $L_{p,LS,n,i}$ caused by the calibrated loudspeaker is determined in the N selected measurement positions. Correct for background noise in accordance with ISO 3744.

The attenuation $D_{n,i}$, in decibels, of pink noise at the considered measurement point n at distance r_n is determined by:

$$D_{n,i} = L_{p,LS,1m,i} - L_{p,LS,n,i} \quad (2)$$

where

- $L_{p,LS,1m,i}$ is the sound pressure level at a distance of 1 m;
- $L_{p,LS,n,i}$ is the sound pressure level at measurement point n ;
- i denotes the octave band.

The spectrum of speech in each octave band i is presented in Table 1. The same attenuation $D_{n,i}$ is valid for any sound power level of the loudspeaker. Therefore, the attenuation is applied to the sound power level of speech, $L_{W,S}$. The sound power level of normal speech is related to the speech spectrum sound pressure level in a distance of 1 m by $L_{W,S} = L_{p,S,1m} + 11$ dB.

The sound pressure level of normal speech in position n and octave band i , $L_{p,S,n,i}$ is the difference of sound pressure level of normal speech reduced by $D_{n,i}$:

$$L_{p,S,n,i} = L_{p,S,1m,i} - D_{n,i} \quad (3)$$

where

- $L_{p,S,1m,i}$ is the sound pressure level of normal speech at a distance of 1 m from the omnidirectional source;
- $D_{n,i}$ is the attenuation at measurement point n determined from Equation (2);
- i denotes the octave band.

Finally, the A-weighted speech level in position n , $L_{p,A,S,n}$, is obtained by adding the values for A-weighting at each octave band and summing on energy basis:

$$L_{p,A,S,n} = 10 \lg \left(\sum_{i=1}^7 10^{\frac{L_{p,S,n,i} + A_i}{10}} \right) \quad (4)$$

where

- $L_{p,S,n,i}$ is the sound pressure level of normal speech in measurement point n determined from Equation (3);
- A_i is the A-weighting correction tabulated in Table 1.

The determination of $D_{2,S}$ is made from the results at measurement positions at distances within the range 2 m to 16 m from the sound source. A logarithmic distance axis and linear regression shall be used. If the last measurement position is close to a reflecting wall, the SPL and STI values increase. In such cases, the last measurement position should be ignored when determining $D_{2,S}$ and r_D .

ISO 3382-3:2012(E)

The determination of the SPL of speech at measurement position n is shown in Figure 2. The spatial decay of A-weighted speech $D_{2,S}$ is determined using the least squares method:

$$D_{2,S} = -\lg(2) \frac{N \sum_{n=1}^N \left[L_{p,A,S,n} \lg\left(\frac{r_n}{r_0}\right) \right] - \sum_{n=1}^N L_{p,A,S,n} \sum_{n=1}^N \lg\left(\frac{r_n}{r_0}\right)}{N \sum_{n=1}^N \left[\lg\left(\frac{r_n}{r_0}\right) \right]^2 - \left[\sum_{n=1}^N \lg\left(\frac{r_n}{r_0}\right) \right]^2} \quad (5)$$

where

- $L_{p,A,S,n}$ is the A-weighted speech level in position n ;
- n is the index number of the single measurement position;
- N is the total number of measurement positions;
- r_n is the distance to measurement position n ;
- r_0 is the reference distance, 1 m.

The determination of $D_{2,S}$ is presented graphically in Figure 3 a).

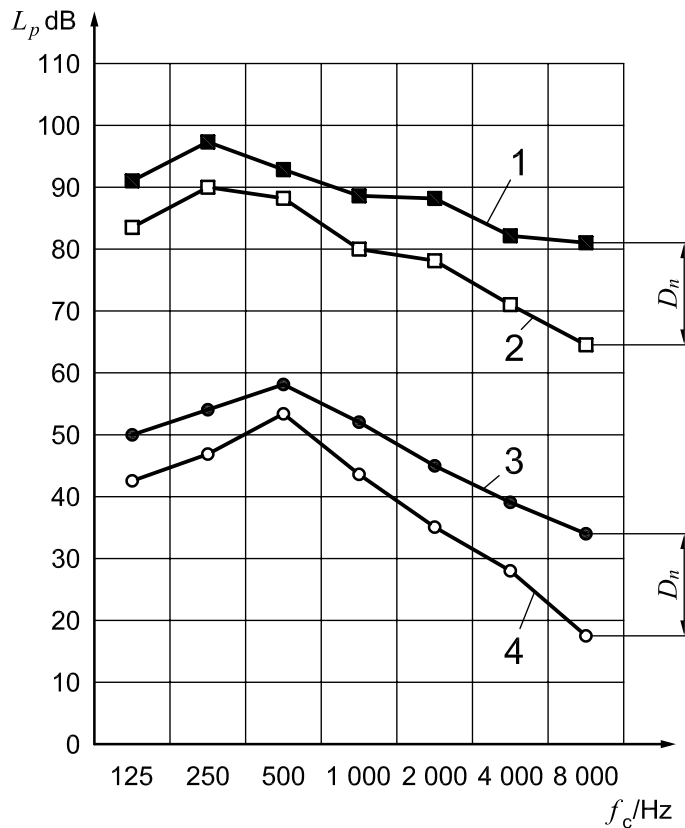

Key

- | | | | |
|---|--|-------|--------------------------------------|
| 1 | sound pressure level of loudspeaker at 1 m in free field, $L_{p,LS,1m}$ | L_p | SPL of octave bands |
| 2 | measured sound pressure level of loudspeaker at point n , $L_{p,LS,n}$ | f_c | centre frequency of octave band |
| 3 | sound pressure level of normal speech at 1 m in free field, $L_{p,S,1m}$ | D_n | attenuation at measurement point n |
| 4 | calculated sound pressure level of speech at point n , $L_{p,S,n}$ | | |

Figure 2 — Determination of the sound pressure level of speech in measurement position n . The attenuation D_n between 1 and 2 is the same as between 3 and 4

6.3 Distraction and privacy distances

The STI is determined according to the full method in accordance with IEC 60268-16 for each source-receiver combination on the measurement path. Auditory masking, hearing threshold and gender-specific differences are not included. A unisex speech spectrum is used because the average result of genders is of primary interest. The STI can also be determined from the impulse response, e.g. using MLS or sweeps, and adjusted for the influence of the background noise.

The background noise level averaged over the measurement positions of the measurement line is used for the determination of STI. This is used because spatial variation of background noise level can cause strong variations in STI and the determination of distraction and privacy distances may not always be unambiguous.

NOTE In addition, STI can be determined by using any other measured or simulated background noise, e.g. from a sound-masking system or from human activities; see IEC 60268-16. However, this provides additional information not within the scope of this part of ISO 3382.

The distraction distance and privacy distance are determined using a linear regression line determined from the STI values as a function of the distance on a linear axis as shown in Figure 3 b).

NOTE It can prove impossible to determine the privacy distance if $STI > 0,20$ in all positions.

6.4 Background noise

Background noise level, $L_{p,B}$, is measured at each measurement position in octave bands. The A-weighted sound pressure level, $L_{p,A,B}$, is determined accordingly. The average background noise level of all the measurement positions is determined.

7 Test report

The test report shall include the following information:

- a) a statement that the measurements were made in conformity with this part of ISO 3382 (ISO 3382-3:2012);
- b) name and location of the room tested;
- c) a sketch of the room plan, with an indication of scale and, if relevant, a section of the room;
- d) room height, and main room dimensions;
- e) condition of the room (furniture, number of persons present, operation of ventilation);
- f) description of floor and ceiling finishes;
- g) description of type and height of screens;
- h) type of sound source, and statement of the directivity characteristics;
- i) a description of the sound signals, measuring apparatus and the microphones;
- j) source and microphone positions shown on the room plan, including screens and storage units between the source and microphone and the height;
- k) measuring results as single number quantities (see Table 2);
- l) spatial sound distribution curves as shown in Figure 3, including measurement data for $L_{p,A,S}$, $L_{p,A,B}$ and STI;
- m) measurement date and name of the measuring organization.

ISO 3382-3:2012(E)

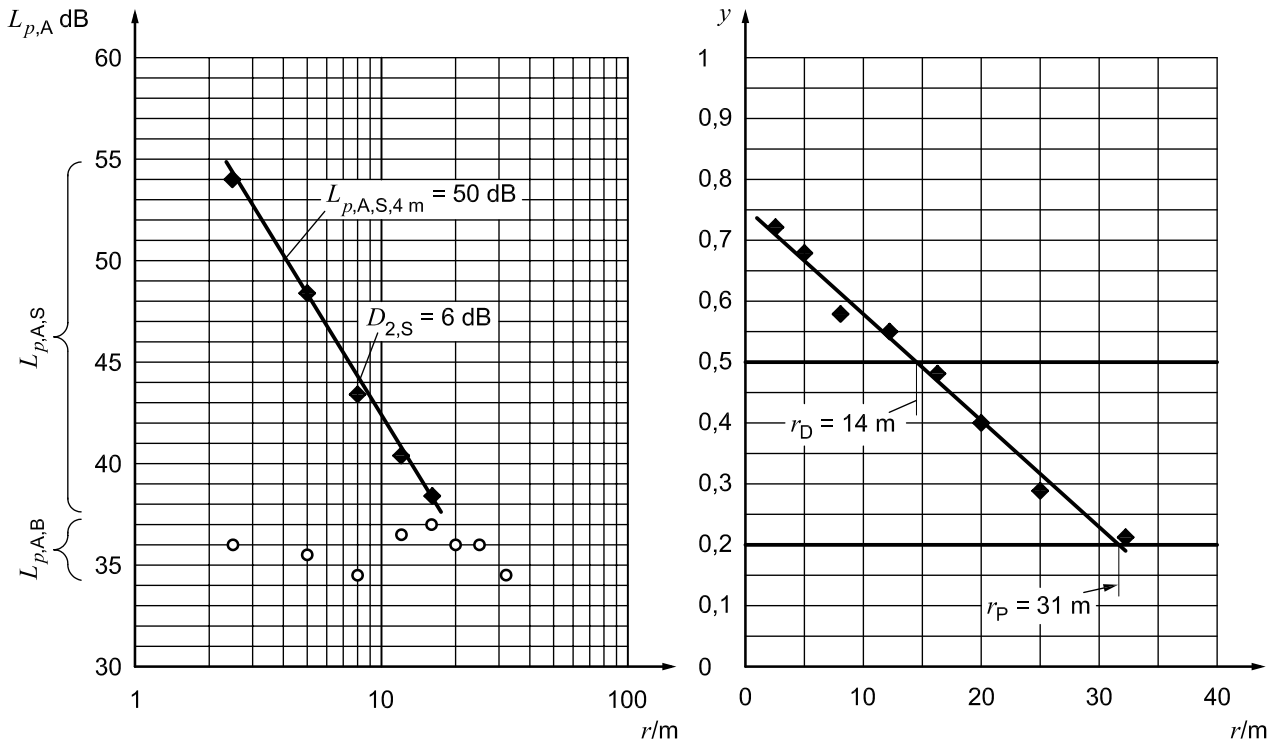

a) The determination of $D_{2,S}$ and $L_{p,A,S,4\text{ m}}$

b) The determination of distraction distance r_D

Key

- $L_{p,A}$ A-weighted sound pressure level
- r distance to the speaker
- $D_{2,S}$ spatial decay rate of speech
- $L_{p,A,B}$ A-weighted sound pressure level of background noise
- $L_{p,A,S}$ A-weighted sound pressure level of speech
- $L_{p,A,S,4\text{ m}}$ A-weighted sound pressure level of speech at 4 m from the sound source

Key

- y speech transmission index
- r distance to the speaker
- r_D distraction distance
- r_P privacy distance

Figure 3 — Examples of the determination of single number quantities from spatial distribution curves

Table 2 — Reporting single number quantities

	Line 1	Line 2
STI in the nearest workstation		
Distraction distance, r_D , in m		
Privacy distance, r_P , in m (if measured)		
Spatial decay rate of A-weighted SPL of speech, $D_{2,S}$, in dB		
A-weighted SPL of speech at 4 metres, $L_{p,A,S,4\text{ m}}$, in dB		
Average A-weighted background noise, $L_{p,A,B}$, in dB		

Annex A (informative)

Examples of target values for evaluation of measurement data

This annex provides some background for the evaluation of measurement results. Results from measurements performed in 16 open plan offices appear in Reference [14]. Further results from five offices (in some cases before and after refurbishment) have been published in Reference [20]. The selected open plan offices varied strongly in geometry, acoustic absorption, furniture, and background noise level.

Most open plan offices have poor or insufficient acoustic conditions. Typical single number values in offices with poor acoustic conditions have $D_{2,S} < 5$ dB, $L_{p,A,S,4\text{ m}} > 50$ dB, and $r_D > 10$ m.

Open plan offices with good acoustic conditions are rare, but an example of target values could be $D_{2,S} \geq 7$ dB, $L_{p,A,S,4\text{ m}} \leq 48$ dB, and $r_D \leq 5$ m.

Annex B (informative)

Relation between speech transmission index and work performance

The noise in open plan offices can consist of many different sounds like speech and laughter, phone ringing tones, footsteps, ventilation noise, external noise, appliance noises, cleaning noises, and artificial masking sounds. According to several field studies, speech is the most annoying and the loudest sound source. It is present in every open plan office, while the existence of the other sounds depends on architectural design and the user's habits.

Speech is necessary, especially during team work where interaction and knowledge exchange is required. Open plan offices were initially intended for this kind of job type. However, open plan offices are more and more often applied for all job types. If the work requires concentration and cognitive resources instead of being routine work, surrounding intelligible speech is often distracting and may affect work performance. In addition, confidential conversations can be impossible to carry out in open plan offices. In such situations, low speech intelligibility, i.e. high speech privacy, between nearby workstations, is desirable. This part of ISO 3382 aims at a method to determine the degree of speech privacy in the office to support the acoustic design.

The effects of irrelevant speech on work performance have been studied using psychological laboratory experiments (see Reference [8]). Perfectly intelligible speech (an STI of 1,00) reduces significantly the performance of cognitively demanding tasks compared to silence when the speech is absent. Cognitively demanding tasks include, e.g. verbal, mathematical, short-term memory, and complex dual tasks. The performance is typically measured by monitoring the error rate. The error rate has been reported at 4 % to 41 % higher during speech than during silence. The large variation is explained by differences in experimental design, like task demands, speech types, time pressure, and exposure time. The evidence is so robust that it is plausible to suggest that cognitive work performance in open plan offices is reduced during irrelevant speech. Questionnaire studies support this suggestion (References [17][18]).

The speech intelligibility is seldom either perfect (an STI of 1,00) or zero (an STI of 0,00). The acoustic conditions of the office (absorption materials, background noise level, screens, etc.) and the distance between the speaker and the listener cause the STI to vary between 0,00 and 1,00. Reference [8] creates a model (Figure B.1) which predicts the reduction of task performance as a function of STI. The results in Reference [19] give strong support to this model.

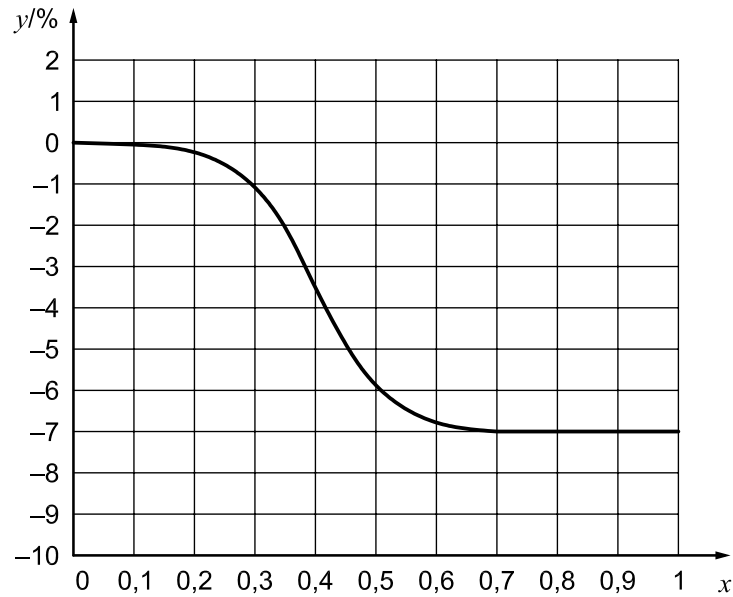

Key

- y minimum change in task performance
- x speech transmission index

Figure B.1 — The effect of STI on the performance of cognitively demanding tasks (see Reference [8])

The model describes the shape of the change in performance, not the exact magnitude. Tasks requiring intensive concentration are more vulnerable to speech than routine tasks. Stress and other work-related factors will amplify the decrease in overall performance in real workplaces. The model has two major consequences to this part of ISO 3382:

- a) The negative effects of speech on work performance start to vanish rapidly if the STI is below 0,50. Therefore, the distraction distance r_D has been set at the distance where STI reaches 0,50.
- b) The negative effects of speech on work performance disappear if the STI is below 0,20. Therefore, the privacy distance r_P has been set at the distance where STI reaches 0,20.

Bibliography

- [1] ISO 3741, *Acoustics — Determination of sound power levels and sound energy levels of noise sources using sound pressure — Precision methods for reverberation test rooms*
- [2] ISO 3743-1, *Acoustics — Determination of sound power levels and sound energy levels of noise sources using sound pressure — Engineering methods for small movable sources in reverberant fields — Part 1: Comparison method for a hard-walled test room*
- [3] ISO 3743-2, *Acoustics — Determination of sound power levels of noise sources using sound pressure — Engineering methods for small, movable sources in reverberant fields — Part 2: Methods for special reverberation test rooms*
- [4] ISO 3745, *Acoustics — Determination of sound power levels and sound energy levels of noise sources using sound pressure — Precision methods for anechoic rooms and hemi-anechoic rooms*
- [5] ANSI S 3.5-1997 (R 2007), *Methods for the calculation of the speech intelligibility index*
- [6] BRADLEY, J.S. The acoustical design of conventional open plan offices. *Can. Acoust.* 2003, **31**(2), pp. 23-31
- [7] CHU, W.T., WARNOCK, A.C.C. *Measurements of sound propagation in open offices*. Ottawa: National Research Council Canada, Institute for Research in Construction, 2002. (IRC Internal Report IR-836.) Available (viewed 2011-12-21) at: <http://www.nrc-cnrc.gc.ca/obj/irc/doc/pubs/ir/ir836/ir836.pdf>
- [8] HONGISTO, V. A model predicting the effect of speech of varying intelligibility on work performance. *Indoor Air* 2005, **15**(6), pp. 458-68
- [9] HOUTGAST, T., STEENEKEN, H.J.M. A review of the MTF concept in room acoustics and its use for estimating speech intelligibility in auditoria. *J. Acoust. Soc. Am.* 1985, **77**(3), pp. 1069-1077
- [10] JONES, D.M., MACKEN, W.J. Auditory babble and cognitive efficiency — Role of number of voices and their location. *J. Exp. Psychol. Appl.* 1995, **1**, pp. 216-226
- [11] KERÄNEN, J., VIRJONEN, P., HONGISTO, V. Characterization of acoustics in open offices — Four case studies. *Proceedings of Acoustics '08*, Paris, 2008-06-29/07-04, paper 713. Available (viewed 2011-12-21) at: <http://intelligence.eu.com/acoustics2008/acoustics2008/cd1/data/articles/000713.pdf>
- [12] POP, C.B., RINDEL, J.H. Speech privacy in open plan offices. *Proceedings of Inter-Noise 2005*, Rio de Janeiro, Brazil, 2005
- [13] SCHROEDER, M.R. Modulation transfer functions: Definition and measurement. *Acustica* 1981, **49**, pp. 179-182
- [14] VIRJONEN, P., KERÄNEN, J., HONGISTO, V. Determination of acoustical conditions in open plan offices — Proposal for new measurement method and target values. *Acta Acust. Acust.* 2009, **95**, pp. 279-290
- [15] VIRJONEN, P., KERÄNEN, J., HELENIUS, R., HAKALA, J., HONGISTO, V. Speech privacy between neighboring workstations in an open office — A laboratory study. *Acta Acust. Acust.* 2007, **93**, pp. 771-782
- [16] *Guidance on computer prediction models to calculate the speech transmission index for BB93*. Version 1.0. Department for Education and Skills, Schools Capital and Building Division, 2004
- [17] HAAPAKANGAS, A., HELENIUS, R., KESKINEN, E., HONGISTO, V. Perceived acoustic environment, work performance and well-being — Survey results from Finnish offices. In: *9th International Congress on Noise as a Public Health Problem (ICBEN)* 2008-07-21/25, Foxwoods, CT, pp. 434-441
- [18] KAARLELA-TUOMAALA, A., HELENIUS, R., KESKINEN, E., HONGISTO, V. Effects of acoustic environment on work in private office rooms and open plan offices — Longitudinal study during relocation. *Ergonomics* 2009, **52**(11), pp. 1423-1444

- [19] HAKA, M., HAAPAKANGAS, A., KERÄNEN, J., HAKALA, J., KESKINEN, E., HONGISTO, V. Performance effects and subjective disturbance of speech in acoustically different office types — A laboratory experiment., *Indoor Air* 2009, **19**(6), pp. 454-467
- [20] NILSSON, E. HELLSTRÖM, B. *Acoustic design of open plan offices*. Nordic Innovation Centre, 2011. 100 p. Available (viewed 2011-12-21) at: <http://www.nordicinnovation.net/nordtestfiler/rep619.pdf>

ISO 3382-3:2012(E)

ICS 91.120.20

Price based on 15 pages