

INTERNATIONAL
STANDARD

ISO
3377-1

IULTCS/IUP
40-1

Second edition
2011-12-15

**Leather — Physical and mechanical
tests — Determination of tear load —**

**Part 1:
Single edge tear**

*Cuir — Essais physiques et mécaniques — Détermination de la force
de déchirement —*

Partie 1: Déchirement d'un seul bord



Reference number
ISO 3377-1:2011(E)
IULTCS/IUP 40-1:2011(E)

© ISO 2011



COPYRIGHT PROTECTED DOCUMENT

© ISO 2011

All rights reserved. Unless otherwise specified, no part of this publication may be reproduced or utilized in any form or by any means, electronic or mechanical, including photocopying and microfilm, without permission in writing from either ISO at the address below or ISO's member body in the country of the requester.

ISO copyright office
Case postale 56 • CH-1211 Geneva 20
Tel. + 41 22 749 01 11
Fax + 41 22 749 09 47
E-mail copyright@iso.org
Web www.iso.org

Published in Switzerland

Foreword

ISO (the International Organization for Standardization) is a worldwide federation of national standards bodies (ISO member bodies). The work of preparing International Standards is normally carried out through ISO technical committees. Each member body interested in a subject for which a technical committee has been established has the right to be represented on that committee. International organizations, governmental and non-governmental, in liaison with ISO, also take part in the work. ISO collaborates closely with the International Electrotechnical Commission (IEC) on all matters of electrotechnical standardization.

International Standards are drafted in accordance with the rules given in the ISO/IEC Directives, Part 2.

The main task of technical committees is to prepare International Standards. Draft International Standards adopted by the technical committees are circulated to the member bodies for voting. Publication as an International Standard requires approval by at least 75 % of the member bodies casting a vote.

Attention is drawn to the possibility that some of the elements of this document may be the subject of patent rights. ISO shall not be held responsible for identifying any or all such patent rights.

ISO 3377-1 was prepared by the European Committee for Standardization (CEN) Technical Committee CEN/TC 289, *Leather*, in collaboration with the Physical Test Commission of the International Union of Leather Technologists and Chemists Societies (IUP Commission, IULTCS), in accordance with the Agreement on technical cooperation between ISO and CEN (Vienna Agreement).

IULTCS, originally formed in 1897, is a world-wide organization of professional leather societies to further the advancement of leather science and technology. IULTCS has three Commissions, which are responsible for establishing international methods for the sampling and testing of leather. ISO recognizes IULTCS as an international standardizing body for the preparation of test methods for leather.

This second edition cancels and replaces the first edition (ISO 3377-1:2002), which has been technically revised with respect to Figure 1 and Table 1, and also Clauses 6 and 7.

ISO 3377 consists of the following parts, under the general title *Leather — Physical and mechanical tests — Determination of tear load*:

- *Part 1: Single edge tear*
- *Part 2: Double edge tear*

Leather — Physical and mechanical tests — Determination of tear load —

Part 1: Single edge tear

1 Scope

This part of ISO 3377 specifies a method for determining the tear strength of leather using a single edge tear. The method is sometimes described as a trouser tear. It is applicable to all types of leather.

2 Normative references

The following referenced documents are indispensable for the application of this document. For dated references, only the edition cited applies. For undated references, the latest edition of the referenced document (including any amendments) applies.

ISO 2418, *Leather — Chemical, physical and mechanical and fastness tests — Sampling location*

ISO 2419, *Leather — Physical and mechanical tests — Sample preparation and conditioning*

ISO 2589, *Leather — Physical and mechanical tests — Determination of thickness*

ISO 7500-1, *Metallic materials — Verification of static uniaxial testing machines — Part 1: Tension/compression testing machines — Verification and calibration of the force-measuring system*

3 Principle

A rectangular test specimen partially slit from one short edge is pulled so that a tear is propagated from the end of the slit. The mean force exerted during separation of the test piece is recorded.

4 Apparatus

4.1 Tensile testing machine, with

- a force range appropriate to the specimen under test,
- a means of recording the force to an accuracy of at least 2 % as specified by Class 2 of ISO 7500-1,
- a uniform speed of separation of the jaws of 100 mm/min \pm 20 mm/min,
- a means of recording the force, e.g. as an extension curve,
- jaws of minimum width 50 mm \pm 2 mm.

4.2 **Thickness gauge**, as specified in ISO 2589.

4.3 **Press knife**, as specified in ISO 2419, capable of cutting rectangular test pieces of the type shown in Figure 1 in one operation. All parts of the press knife shall lie in the same plane.

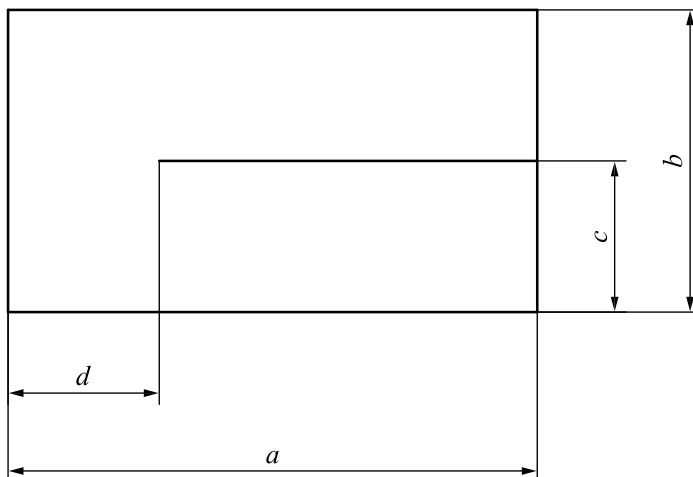

Figure 1 — Test piece for single edge tear

Table 1 — Dimensions of test piece

Dimensions in millimetres (tolerance ± 1 mm)

Designation	a	b	c	d
Standard	70	40	$b/2$	20
Large	100	50	$b/2$	50

If “large” test pieces are used, the size of the test piece shall be mentioned in the test report.

NOTE For manual evaluation, it is advantageous to use the “large” specimen.

5 Sampling and sample preparation

5.1 Sample in accordance with ISO 2418. From the sample, cut six test pieces in accordance with ISO 2419, three test pieces with the longer side parallel to the backbone and three test pieces with the longer side perpendicular to the backbone.

If there is a requirement for more than two hides or skins to be tested in one batch, then only one test piece in each direction need be taken from each hide or skin, provided that the overall total is not less than three test pieces in each direction.

5.2 Condition the test pieces in accordance with ISO 2419.

5.3 Measure the thickness of the test pieces in accordance with ISO 2589.

6 Procedure

6.1 Set the jaws of the tensile testing machine (4.1) so that the clamps are at a suitable distance to firmly hold the test piece (e.g. 50 mm).

6.2 Clamp one leg of the test piece in one jaw of the tensile test machine (see Figure 2). Fold the other leg through 180° and clamp in the other jaw. Ensure that the long edges of the test piece are parallel to the testing direction of the machine.

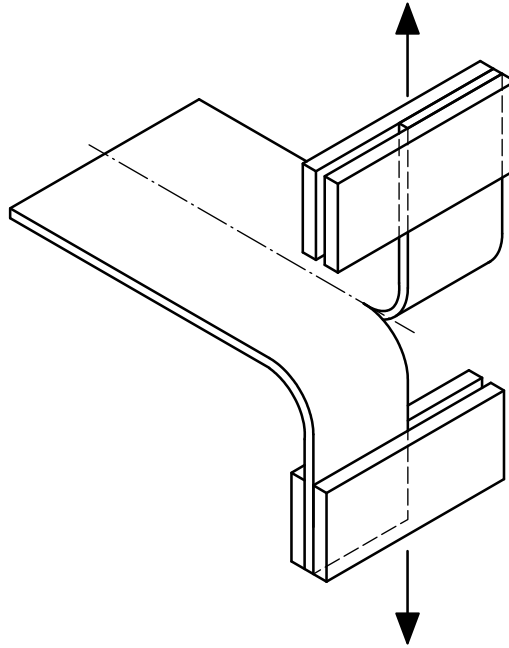

Figure 2 — Method of fixing test piece in jaws of the tensile test machine

6.3 Run the tensile test machine until the test piece is torn apart and record the force-extension plot.

6.4 Determine the tear load of the test piece as the arithmetic mean of the forces on the peak trace, proceeding in the following way.

Divide the peak trace into four equal parts, beginning with the first peak and ending with the last peak. The first part and the last part shall not be used to calculate the mean value. Determine the tear load as the mean value, in newtons, of the two remaining middle subsections. In the electronic evaluation method, all the data points of the force in the middle subsections of the trace are taken into consideration.

If the manual calculation method is used, select and note the two highest peaks (maxima) and the two lowest valleys (minima) from each of the middle subsections (i.e. eight values). Peaks and valleys suitable for calculation are characterized by a 10 % minimum rising and falling of force. Tear load is defined by the arithmetic mean of these values. The use of this evaluation method shall be mentioned in the test report.

Depending on the evaluation procedure chosen, a different number of values is taken into consideration as the calculation basis. Consequently, the results of the two calculation methods may differ. Being more precise, the electronic method shall be preferred.

In some cases, due to the lack of distinguishable peaks and valleys, evaluating the trace can be difficult. Such results shall be rejected and the test repeated.

In case of litigation, the tear load shall only be determined using the electronic evaluation method on test pieces with standard dimensions (4.3).

6.5 Repeat 6.2 to 6.4 for other test pieces.

7 Test report

The test report shall include the following:

- a) a reference to this part of ISO 3377, i.e. ISO 3377-1:2011;
- b) full details for the identification of the sample and any deviations from ISO 2418 with respect to sampling;
- c) if the “standard” test piece size was not used, a mention that the “large” test piece size was used;
- d) if the electronic evaluation method was not used, a mention that the manual evaluation method was used;
- e) the thickness of the leather, in millimetres (mm);
- f) the mean tear load, in newtons (N), to the nearest 0,1 N for test pieces with the longer edge cut parallel to the backbone;
- g) the mean tear load, in newtons (N), to the nearest 0,1 N for test pieces with the longer edge perpendicular to the backbone;
- h) the average tear load to the nearest 0,1 N [i.e. the arithmetic mean of f) and g)], if required by the customer or by specifications;
- i) the standard atmosphere used for conditioning and testing, as given in ISO 2419;
- j) any deviations from the method specified in this part of ISO 3377.

ICS 59.140.30

Price based on 4 pages