

---

---

**Textile glass — Determination of stiffness  
of rovings**

*Verre textile — Détermination de la rigidité des stratifils*



Reference number  
ISO 3375:2009(E)

© ISO 2009

**PDF disclaimer**

This PDF file may contain embedded typefaces. In accordance with Adobe's licensing policy, this file may be printed or viewed but shall not be edited unless the typefaces which are embedded are licensed to and installed on the computer performing the editing. In downloading this file, parties accept therein the responsibility of not infringing Adobe's licensing policy. The ISO Central Secretariat accepts no liability in this area.

Adobe is a trademark of Adobe Systems Incorporated.

Details of the software products used to create this PDF file can be found in the General Info relative to the file; the PDF-creation parameters were optimized for printing. Every care has been taken to ensure that the file is suitable for use by ISO member bodies. In the unlikely event that a problem relating to it is found, please inform the Central Secretariat at the address given below.



**COPYRIGHT PROTECTED DOCUMENT**

© ISO 2009

All rights reserved. Unless otherwise specified, no part of this publication may be reproduced or utilized in any form or by any means, electronic or mechanical, including photocopying and microfilm, without permission in writing from either ISO at the address below or ISO's member body in the country of the requester.

ISO copyright office  
Case postale 56 • CH-1211 Geneva 20  
Tel. + 41 22 749 01 11  
Fax + 41 22 749 09 47  
E-mail [copyright@iso.org](mailto:copyright@iso.org)  
Web [www.iso.org](http://www.iso.org)

Published in Switzerland

## Foreword

ISO (the International Organization for Standardization) is a worldwide federation of national standards bodies (ISO member bodies). The work of preparing International Standards is normally carried out through ISO technical committees. Each member body interested in a subject for which a technical committee has been established has the right to be represented on that committee. International organizations, governmental and non-governmental, in liaison with ISO, also take part in the work. ISO collaborates closely with the International Electrotechnical Commission (IEC) on all matters of electrotechnical standardization.

International Standards are drafted in accordance with the rules given in the ISO/IEC Directives, Part 2.

The main task of technical committees is to prepare International Standards. Draft International Standards adopted by the technical committees are circulated to the member bodies for voting. Publication as an International Standard requires approval by at least 75 % of the member bodies casting a vote.

Attention is drawn to the possibility that some of the elements of this document may be the subject of patent rights. ISO shall not be held responsible for identifying any or all such patent rights.

ISO 3375 was prepared by Technical Committee ISO/TC 61, *Plastics*, Subcommittee SC 13, *Composites and reinforcement fibres*.

This second edition cancels and replaces the first edition (ISO 3375:1975), of which it constitutes a minor revision. The main changes are as follows:

- a) the sampling clause has been deleted (the sampling standard referred to in the previous edition, ISO 1886, has been withdrawn without replacement);
- b) the specimen-conditioning time has been changed from 48 h to a minimum of 6 h.

Copyright International Organization for Standardization

# Textile glass — Determination of stiffness of rovings

## 1 Scope

This International Standard specifies a method for the determination of the stiffness of textile glass rovings.

## 2 Normative references

The following referenced documents are indispensable for the application of this document. For dated references, only the edition cited applies. For undated references, the latest edition of the referenced document (including any amendments) applies.

ISO 291, *Plastics — Standard atmospheres for conditioning and testing*

## 3 Principle

A test specimen of defined length is suspended at its centre, and the separation of the two hanging ends of the specimen measured at a standard distance below the point of suspension.

## 4 Apparatus

**4.1 Means for the controlled unwinding of the roving** (see Figure 1).

**4.2 Roving stiffness tester**, consisting of a stainless-steel hook of circular cross-section and a sliding scale positioned 60 mm below the point of suspension (see Figure 2).

## 5 Conditioning

The roving shall be unpacked and the packages conditioned for at least 6 h in one of the standard laboratory atmospheres specified in ISO 291.

## 6 Procedure

**6.1** Carry out the test in one of the standard atmospheres specified in ISO 291.

**6.2** Unwind the roving from the outside of the package as shown in Figure 1, pulling it through the guide eye and round the stainless-steel rollers.

**6.3** The speed of unwinding shall be about 100 mm/s, since the roving must be handled carefully, without too much tension.

**6.4** Before taking test specimens from the outer layer of the package, first remove at least 10 m of the roving.

Then cut off five test specimens, each  $(500 \pm 5)$  mm long, with a sharp knife.

**6.5** Drape one of the test specimens over the hook, ensuring that an equal length of the test specimen is hanging down on each side, and wait  $(30 \pm 5)$  s before making any measurements.

**6.6** Stand directly in front of the end of the test specimen hanging to the left of the hook (to avoid any parallax error) and align the zero point of the sliding scale with the centre of the roving.

**6.7** Move to stand directly in front of the end of the test specimen hanging on the right of the hook (to avoid any parallax error) and read off the distance, in millimetres, between the centres of the hanging ends of the roving.

**6.8** Always take the readings at the position where the centres of the draped test specimen intersect the top of the sliding scale, situated 60 mm below the top of the hook.

**6.9** Proceed in the same way with the remaining four test specimens.

## **7 Expression of results**

Report the arithmetic mean of the five measurements, expressed in millimetres, as the stiffness of the roving.

## **8 Test report**

The test report shall include the following particulars:

- a) a reference to this International Standard;
- b) all details necessary for complete identification of the roving tested;
- c) the outer diameter of the package from which the specimens were taken;
- d) details of the conditioning and test atmosphere used;
- e) the individual results and their mean;
- f) the date of the test.

Dimensions in millimetres

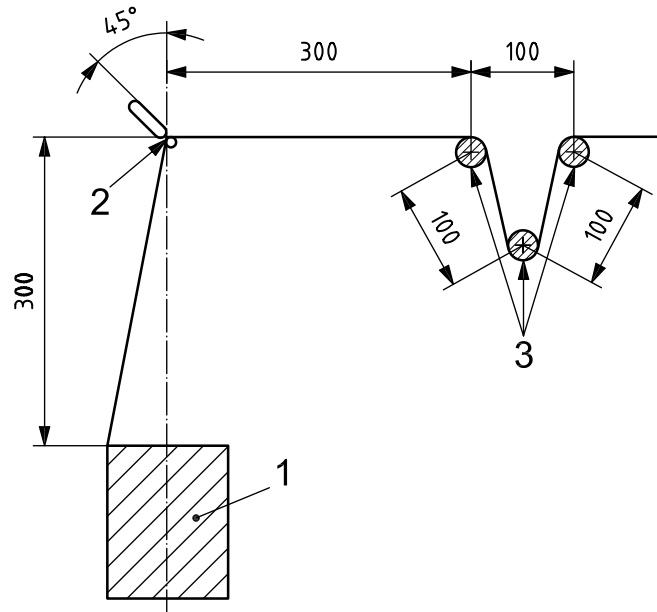

**Key**

- 1 roving package
- 2 ceramic guide eye
- 3 stainless-steel rollers, diameter 10 mm

**Figure 1 — Means for the controlled unwinding of the roving**

Dimensions in millimetres

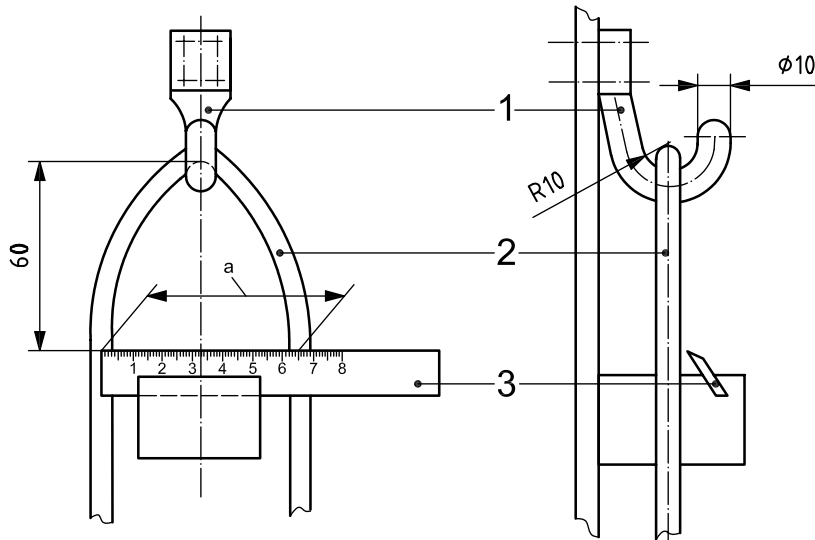

**Key**

- 1 stainless-steel hook
- 2 test specimen
- 3 sliding scale
- a Stiffness of the roving.

**Figure 2 — Roving stiffness tester**

---

---

**ICS 59.100.10**

Price based on 3 pages