

# INTERNATIONAL STANDARD

**ISO**  
**3366**

Second edition  
1999-10-15

---

---

## **Coated abrasives — Abrasive rolls**

*Abrasifs appliqués — Rouleaux abrasifs*



Reference number  
ISO 3366:1999(E)

## Foreword

ISO (the International Organization for Standardization) is a worldwide federation of national standards bodies (ISO member bodies). The work of preparing International Standards is normally carried out through ISO technical committees. Each member body interested in a subject for which a technical committee has been established has the right to be represented on that committee. International organizations, governmental and non-governmental, in liaison with ISO, also take part in the work. ISO collaborates closely with the International Electrotechnical Commission (IEC) on all matters of electrotechnical standardization.

International Standards are drafted in accordance with the rules given in the ISO/IEC Directives, Part 3.

Draft International Standards adopted by the technical committees are circulated to the member bodies for voting. Publication as an International Standard requires approval by at least 75 % of the member bodies casting a vote.

International Standard ISO 3366 was prepared by Technical Committee ISO/TC 29, *Small tools*, Subcommittee SC 5, *Grinding wheels and abrasives*.

This second edition cancels and replaces the first edition (ISO 3366:1975) as well as ISO 3367:1975 and ISO 3368:1975 the contents of which, after technical revision, have been combined.

© ISO 1999

All rights reserved. Unless otherwise specified, no part of this publication may be reproduced or utilized in any form or by any means, electronic or mechanical, including photocopying and microfilm, without permission in writing from the publisher.

International Organization for Standardization  
Case postale 56 • CH-1211 Genève 20 • Switzerland  
Internet iso@iso.ch

Printed in Switzerland

# Coated abrasives — Abrasive rolls

## 1 Scope

This International Standard specifies the dimensions and limit deviations for coated abrasive rolls and their designation.

## 2 Normative reference

The following normative document contains provisions which, through reference in this text, constitute provisions of this International Standard. For dated references, subsequent amendments to, or revisions of, any of these publications do not apply. However, parties to agreements based on this International Standard are encouraged to investigate the possibility of applying the most recent edition of the normative document indicated below. For undated references, the latest edition of the normative document referred to applies. Members of ISO and IEC maintain registers of currently valid International Standards.

ISO 554:1976, *Standard atmospheres for conditioning and/or testing — Specifications.*

### 3 Requirements

#### 3.1 Types and dimensions

See Figures 1 and 2 and Table 1.

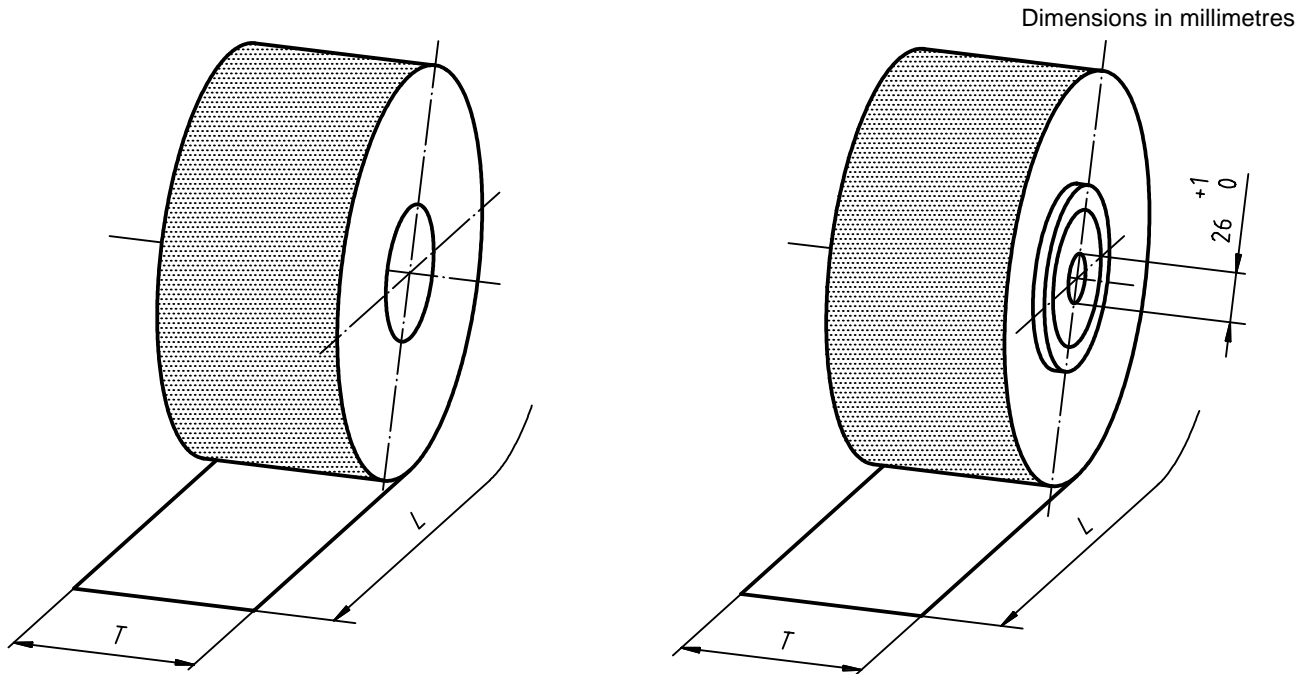

Figure 1 — Type A — Roll without flange and without core

Figure 2 — Type B — Roll incorporate flange or core

Table 1 — Dimensions

$T$ mm		$L$ mm $\pm 1\%$	Type A	Type B
nominal	tolerance		(without flange)	(incorporate)
12,5	$\pm 1$	25 000 or 50 000	×	×
15			×	×
25			×	×
35	$\pm 2$		×	×
40			×	×
50			×	×
80			×	×
93			×	×
100		50 000 <sup>a</sup>	×	—
115	×			
150	×			
200	×			
300	×			
600	×			

<sup>a</sup> If longer rolls are required for these widths they shall have the multiple length of 50 000 mm.

### 3.2 Test conditions

The limit deviations given in Table 1 are valid under the following conditions:

- temperature:  $20\text{ °C} \pm 2\text{ °C}$
  - relative humidity:  $65\% \pm 5\%$
- } in accordance with ISO 554

When abrasive rolls are tested they shall be stored for at least 24 h under the above conditions.

## 4 Designation

Abrasive rolls conforming to this International Standard shall be designated by

- a) "Abrasive roll";
- b) reference to this International Standard, i.e. ISO 3366;
- c) Type A or B;
- d) width  $T$  in millimetres;
- e) length  $L$  in millimetres.

EXAMPLE An abrasive roll of Type A, width  $T = 25\text{ mm}$  and length  $L = 50\ 000\text{ mm}$  is designated as follows:

**Abrasive roll ISO 3366 A 25 × 50 000**

## 5 Marking

Marking shall be at the manufacturer's discretion.

www.iso.org

---

---

**ICS 25.100.70**

Price based on 3 pages

---

---

