**Indexable hardmetal (carbide) inserts
with wiper edges, without fixing
hole — Dimensions**

*Plaquettes amovibles en métaux-durs (carbures métalliques) avec
arêtes de planage, sans trou de fixation — Dimensions*



COPYRIGHT PROTECTED DOCUMENT

© ISO 2016, Published in Switzerland

All rights reserved. Unless otherwise specified, no part of this publication may be reproduced or utilized otherwise in any form or by any means, electronic or mechanical, including photocopying, or posting on the internet or an intranet, without prior written permission. Permission can be requested from either ISO at the address below or ISO's member body in the country of the requester.

ISO copyright office
Ch. de Blandonnet 8 • CP 401
CH-1214 Vernier, Geneva, Switzerland
Tel. +41 22 749 01 11
Fax +41 22 749 09 47
copyright@iso.org
www.iso.org

Contents

Page

Foreword	iv
1 Scope	1
2 Normative references	1
3 Types of inserts	1
4 Interchangeability	2
4.1 Tolerances	2
4.2 Dimensions <i>m</i>	2
5 Designation and marking	2
5.1 Designation	2
5.2 Marking	2
6 Measurement	2
7 Recommended dimensions	3
7.1 Triangular inserts	3
7.1.1 Symmetrical triangular inserts with 90° cutting edge angle, 11° normal clearance, and 11° wiper edge normal clearance	3
7.1.2 Asymmetrical triangular inserts with chamfered corners, 90° cutting edge angle, 11° normal clearance, and 15° wiper edge normal clearance	4
7.1.3 Asymmetrical triangular inserts with chamfered corners, 90° cutting edge angle, 20° normal clearance, and 20° wiper edge normal clearance	5
7.2 Square inserts	6
7.2.1 Symmetrical square inserts with chamfered corner, 75° cutting edge angle, 0° normal clearance, and 0° wiper edge normal clearance	6
7.2.2 Asymmetrical square inserts with chamfered corner, 75° cutting edge angle, 11° normal clearance, and 15° wiper edge normal clearance	7
7.2.3 Symmetrical square inserts with 45° cutting edge angle, 0° normal clearance, and 0° wiper edge normal clearance	8
7.2.4 Asymmetrical square inserts without chamfered corner, 75° cutting edge angle, 20° normal clearance, and 20° wiper edge normal clearance	9
Annex A (normative) Tolerances for <i>d</i>, <i>m</i>, and <i>s</i>	10
Annex B (normative) Method of measurement of “<i>m</i>” dimension	11
Annex C (normative) Range of sizes for inserts with wiper edges, without fixation hole	12
Annex D (informative) Relationship between designations in this International Standard and ISO 13399	14
Bibliography	15

Foreword

ISO (the International Organization for Standardization) is a worldwide federation of national standards bodies (ISO member bodies). The work of preparing International Standards is normally carried out through ISO technical committees. Each member body interested in a subject for which a technical committee has been established has the right to be represented on that committee. International organizations, governmental and non-governmental, in liaison with ISO, also take part in the work. ISO collaborates closely with the International Electrotechnical Commission (IEC) on all matters of electrotechnical standardization.

The procedures used to develop this document and those intended for its further maintenance are described in the ISO/IEC Directives, Part 1. In particular the different approval criteria needed for the different types of ISO documents should be noted. This document was drafted in accordance with the editorial rules of the ISO/IEC Directives, Part 2 (see www.iso.org/directives).

Attention is drawn to the possibility that some of the elements of this document may be the subject of patent rights. ISO shall not be held responsible for identifying any or all such patent rights. Details of any patent rights identified during the development of the document will be in the Introduction and/or on the ISO list of patent declarations received (see www.iso.org/patents).

Any trade name used in this document is information given for the convenience of users and does not constitute an endorsement.

For an explanation on the meaning of ISO specific terms and expressions related to conformity assessment, as well as information about ISO's adherence to the WTO principles in the Technical Barriers to Trade (TBT) see the following URL: [Foreword - Supplementary information](#)

The committee responsible for this document is ISO/TC 29, *Small tools*, Subcommittee SC 9, *Tools with defined cutting edges, cutting items*.

This third edition cancels and replaces the second edition (ISO 3365:1985), of which it constitutes a minor revision.

Indexable hardmetal (carbide) inserts with wiper edges, without fixing hole — Dimensions

1 Scope

This International Standard specifies the dimensions of indexable hardmetal (carbide) inserts with wiper edges, without fixing hole. These inserts are primarily intended to be mounted on milling cutters by top or wedge clamping.

2 Normative references

The following documents, in whole or in part, are normatively referenced in this document and are indispensable for its application. For dated references, only the edition cited applies. For undated references, the latest edition of the referenced document (including any amendments) applies.

ISO 513, *Classification and application of hard cutting materials for metal removal with defined cutting edges — Designation of the main groups and groups of application*

ISO 1832, *Indexable inserts for cutting tools — Designation*

3 Types of inserts

The types of indexable hardmetal (carbide) inserts specified in this International Standard are the following:

— TP ... PPN

symmetrical triangular inserts with 11° normal clearance, 90° cutting edge angle, and 11° wiper edge normal clearance;

— TP ... PDR; TP ... PDL

asymmetrical triangular inserts with chamfered corners, 11° normal clearance, 90° cutting edge angle, and 15° wiper edge normal clearance;

— TE ... PER; TE ... PEL

asymmetrical triangular inserts with chamfered corners, 20° normal clearance, 90° cutting edge angle, and 20° wiper edge normal clearance;

— SN ... ENN

symmetrical square insert with chamfered corners, 0° normal clearance, 75° cutting edge angle, and 0° wiper edge normal clearance;

— SP ... EDR; SP ... EDL

asymmetrical square insert with chamfered corners, 11° normal clearance, 75° cutting edge angle, and 15° wiper edge normal clearance;

— SN ... ANN

symmetrical square insert with 0° normal clearance, 45° cutting edge angle, and 0° wiper edge normal clearance;

— SE.... EER; SE.... EEL

asymmetrical square insert with 20° normal clearance, 75° cutting edge angle, and 20° wiper edge normal clearance.

Inserts with wiper edges, without fixing hole, are standardized only without chip breakers.

4 Interchangeability

4.1 Tolerances

Indexable hardmetal (carbide) inserts specified in this International Standard are provided in the following tolerance classes in accordance with ISO 1832:

- a) inserts with 0° and 11° normal clearance (TP, SN, and SP)
tolerance classes A, C, and K, where class C is used mainly for coated inserts;
- b) inserts with 20° normal clearance (TE and SE)
tolerance class C.

The values of the tolerances in accordance with ISO 1832 are given in [Annex A](#).

Other tolerances are included in the diagrams and tables with the insert dimensions in [Clause 7](#).

4.2 Dimensions *m*

Dimension *m* specified in the tables refers to a theoretically perfect insert. In practice, as the points on which the inserts are located in both manufacturing and measuring may be different, the nominal value of dimension *m* may vary from one manufacturer to another within a range of $\pm 0,05$ mm. Nevertheless, for inserts of the same manufacturer, dimension *m* shall comply with the tolerances in accordance with ISO 1832 (see [Annex A](#)).

5 Designation and marking

5.1 Designation

The designation of the indexable hardmetal (carbide) inserts complying with this International Standard shall conform to ISO 1832.

In addition to this designation, one or both of the following may be indicated:

- the symbol of the group of application, in accordance with ISO 513;
- the commercial designation of the hardmetal (carbide) grade.

5.2 Marking

The following symbol, at least, shall be marked on the insert itself (except when this would be difficult on the smaller inserts):

- symbol of the group of application or commercial designation of the hardmetal (carbide) grade (or both, if possible, on large inserts).

6 Measurement

[Annex B](#) indicates the methods of measuring the dimension *m* of the indexable inserts covered by this International Standard.

7 Recommended dimensions

The choice of the more common dimensions is restricted to the specifications given in [Tables 1](#) to [12](#). It is strongly recommended that these standard inserts be used wherever possible.

7.1 Triangular inserts

7.1.1 Symmetrical triangular inserts with 90° cutting edge angle, 11° normal clearance, and 11° wiper edge normal clearance

TPAN ... PPN

TPCN ... PPN

TPKN ... PPN

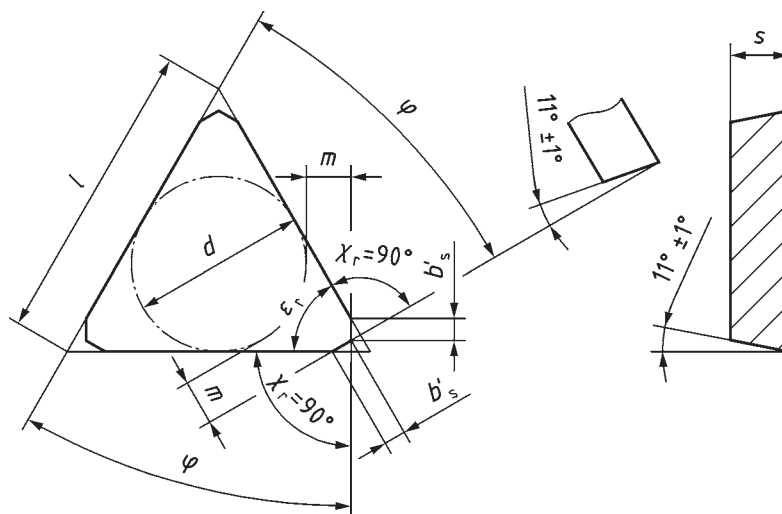

Figure 1

Table 1

Values in millimetres

Insert			l	d^a	s^a	m^a	b'_s	ϵ_r	φ
			\approx				\approx		
TPAN1103 PPN	TPCN1103 PPN	TPKN1103 PPN	11,0	6,35	3,175	1,72	0,7	60°	30°
TPAN1603 PPN	TPCN1603 PPN	TPKN1603 PPN	16,5	9,525		2,45	1,2		
TPAN2204 PPN	TPCN2204 PPN	TPKN2204 PPN	22,0	12,70		3,55	1,3		

^a Tolerances in accordance with ISO 1832. See [Annex A](#).

Table 2

Tolerance class	Tolerances on	
	ϵ_r	φ
A	$\pm 8'$	$+ 15'$ 0
C		
K	$\pm 30'$	$+ 30'$ 0

7.1.2 Asymmetrical triangular inserts with chamfered corners, 90° cutting edge angle, 11° normal clearance, and 15° wiper edge normal clearance

TPAN ... PD.

TPCN ... PD.

TPKN ... PD.

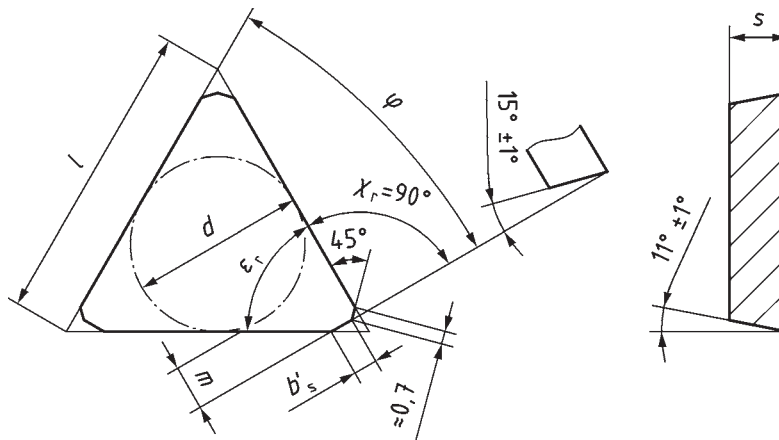

Figure 2

Table 3

Values in millimetres

Insert			l	d^a	s^a	m^a	b'_s	ϵ_r	φ
			\approx				\approx		
TPAN1603 PDR	TPCN1603 PDR	TPKN1603 PDR	16,5	9,525	3,175	2,45	1,3	60°	30°
TPAN1603 PDL	TPCN1603 PDL	TPKN1603 PDL							
TPAN2204 PDR	TPCN2204 PDR	TPKN2204 PDR	22,0	12,70	4,76	3,55			
TPAN2204 PDL	TPCN2204 PDL	TPKN2204 PDL							

^a Tolerances in accordance with ISO 1832. See Annex A.

Table 4

Tolerance class	Tolerances on	
	ε_r	φ
A	$\pm 8'$	$+15'$ 0
C		
K	$\pm 30'$	$+30'$ 0

7.1.3 Asymmetrical triangular inserts with chamfered corners, 90° cutting edge angle, 20° normal clearance, and 20° wiper edge normal clearance

TECN ... PE.

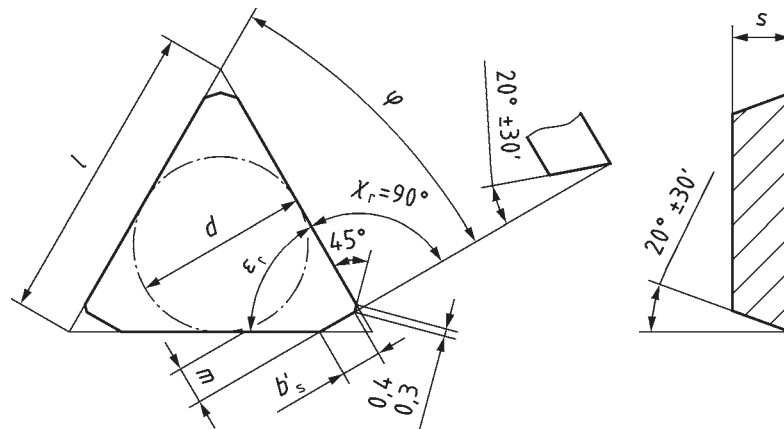

Figure 3

Table 5

Values in millimetres

Insert	l \approx	d^a	s^a	m^a	b'_s \approx	ε_r	φ $+15'$ 0
TECN1603 PER TECN1603 PEL	16,5	9,525	3,175	2,19	2,0	60°	30°

^a Tolerances in accordance with ISO 1832. See [Annex A](#).

7.2 Square inserts

7.2.1 Symmetrical square inserts with chamfered corner, 75° cutting edge angle, 0° normal clearance, and 0° wiper edge normal clearance

SNAN ... ENN
 SNCN ... ENN
 SNKN ... ENN

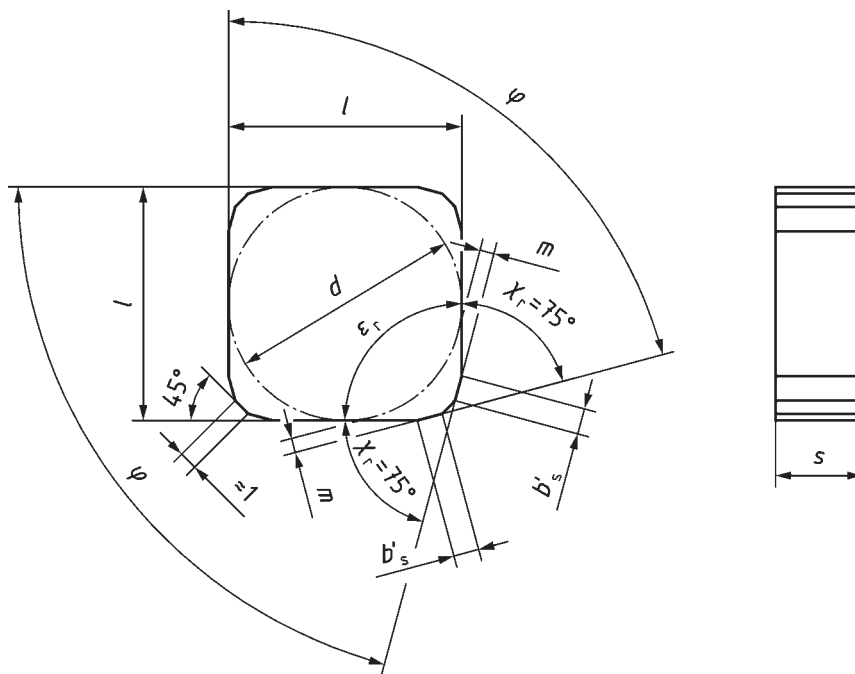

Figure 4

Table 6

Values in millimetres

Insert			d^a	s^a	m^a	b'_s \approx	ϵ_r	ϕ
SNAN1204 ENN	SNCN1204 ENN	SNKN1204 ENN	12,70	4,76	0,80	1,4	90°	75°
SNAN1504 ENN	SNCN1504 ENN	SNKN1504 ENN	15,875		1,50			
SNAN1904 ENN	SNCN1904 ENN	SNKN1904 ENN	19,05	4,76 ^b	1,30	2,0		

^a Tolerances in accordance with ISO 1832. See Annex A.
^b For national standards, a thickness of 5,56 mm (SN. N1905 ENN) may be used as an alternative to that of 4,76 mm.

Table 7

Tolerance class	Tolerances on	
	ϵ_r	φ
A	$\pm 8'$	$+15'$ 0
C		
K	$\pm 30'$	$+30'$ 0

7.2.2 Asymmetrical square inserts with chamfered corner, 75° cutting edge angle, 11° normal clearance, and 15° wiper edge normal clearance

SPAN ... ED.

SPCN ... ED.

SPKN ... ED.

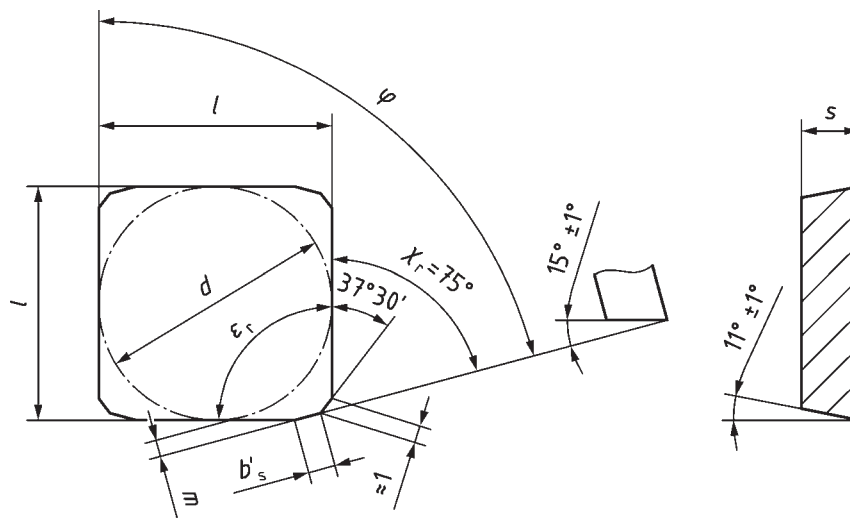

Figure 5

Table 8

Values in millimetres

Insert			d^a	s^a	m^a	b'_s ≈	ϵ_r	φ
SPAN1203 EDR	SPCN1203 EDR	SPKN1203 EDR	12,70	3,175	0,90	1,4	90°	75°
SPAN1203 EDL	SPCN1203 EDL	SPKN1203 EDL						
SPAN1504 EDR	SPCN1504 EDR	SPKN1504 EDR	15,875	4,76	1,25			
SPAN1504 EDL	SPCN1504 EDL	SPKN1504 EDL						

^a Tolerances in accordance with ISO 1832. See [Annex A](#).

Table 9

Tolerance class	Tolerances on	
	ϵ_r	φ
A	$\pm 8'$	$+ \begin{matrix} 15' \\ 0 \end{matrix}$
C		
K	$\pm 30'$	$+ \begin{matrix} 30' \\ 0 \end{matrix}$

7.2.3 Symmetrical square inserts with 45° cutting edge angle, 0° normal clearance, and 0° wiper edge normal clearance

SNAN ... ANN
 SNCN ... ANN
 SNKN ... ANN

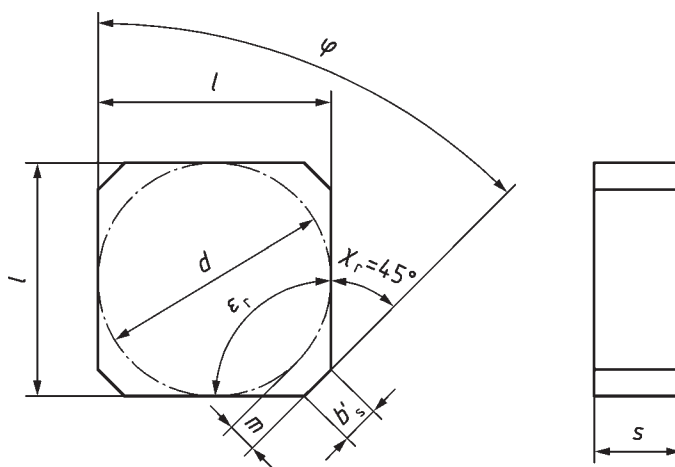

Figure 6

Table 10

Values in millimetres

Insert			d^a	s^a	m^a	b'_s \approx	ϵ_r	φ
SNAN1204 ANN	SNCN1204 ANN	SNKN1204 ANN	12,70	4,76	1,60	2,0	90°	45°
SNAN1504 ANN	SNCN1504 ANN	SNKN1504 ANN	15,875		2,00	2,5		
SNAN1904 ANN	SNCN1904 ANN	SNKN1904 ANN	19,05	4,76 ^b	2,50	3,0		

^a Tolerances in accordance with ISO 1832. See [Annex A](#).
^b For national standards, a thickness of 5,56 mm (SN. M1905 ANN) may be used as an alternative to that of 4,76 mm.

Table 11

Tolerance class	Tolerances on	
	ϵ_r	φ
A	$\pm 8'$	$\pm 8'$
C		
K	$\pm 30'$	$\pm 15'$

7.2.4 Asymmetrical square inserts without chamfered corner, 75° cutting edge angle, 20° normal clearance, and 20° wiper edge normal clearance

SECN ... EE.

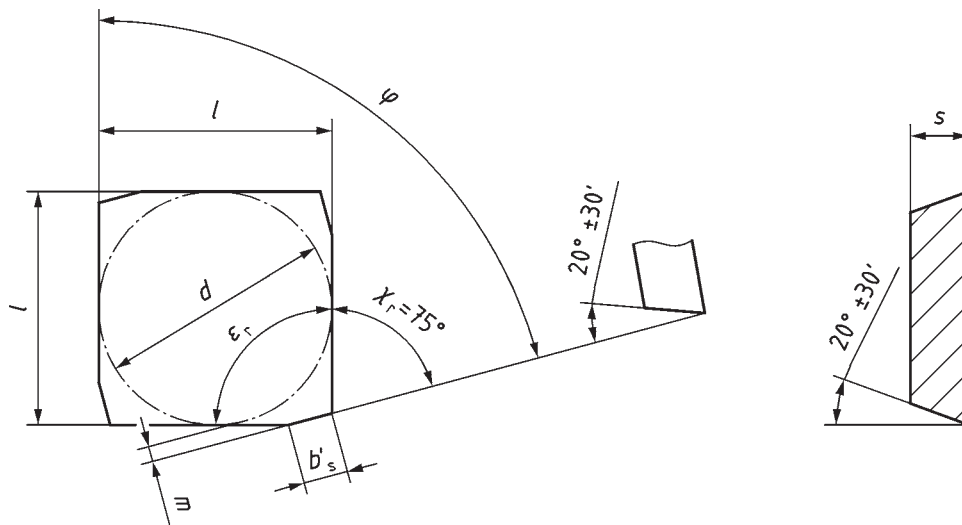

Figure 7

Table 12

Values in millimetres

Insert	d^a	s^a	m^a	b'_s \approx	ϵ_r $\pm 8'$	φ $+ \frac{15'}{0}$
SECN1203 EER SECN1203 EEL	12,70	3,175	0,8	2,5	90°	75°
^a Tolerances in accordance with ISO 1832. See Annex A .						

Annex A (normative)

Tolerances for *d*, *m*, and *s*

A.1 Tolerance class A

Table A.1

Values in millimetres

Tolerance for	<i>d</i>	±0,025
	<i>m</i>	±0,005
	<i>s</i>	±0,025

A.2 Tolerance class C

Table A.2

Values in millimetres

Tolerance for	<i>d</i>	±0,025
	<i>m</i>	±0,013
	<i>s</i>	±0,025

A.3 Tolerance class K

Table A.3

Values in millimetres

Insert		Tolerances for		
Designation	<i>d</i>	<i>d</i>	<i>m</i>	<i>s</i>
T ... 11 ...	6,35	±0,05	±0,013	±0,025
T ... 16 ...	9,525	±0,05		
T ... 22 ...	12,70	±0,08		
S ... 12 ...				
S ... 15 ...	15,875	±0,10		
S ... 19 ...	19,05	±0,10		

Annex B (normative)

Method of measurement of “*m*” dimension

B.1 Triangular inserts

Dimension *m* is checked by reference to the diameter *d* of a precision roller, where *d* corresponds to the nominal diameter of the inscribed circle of the insert. The insert is mounted on a 60° vee-block as shown in [Figure B.1](#) and checked by means of a dial gauge which has been zeroed to dimension *m* by means of a roller with the aid of a gauge block. The dial gauge then gives a direct reading of the error when applied to the inserts to be measured. The roller has a tolerance of $\pm 0,002$ mm.

B.2 Square inserts

Dimension *m* is checked by reference to the diameter *d* of a precision roller, where *d* corresponds to the nominal diameter of the inscribed circle of the insert. The insert is mounted on a 90° vee-block as shown in [Figure B.2 a\)](#) for inserts with $\kappa_r = 75^\circ$ (SN ... ENN, SP ... ED, and SE ... EE) and in [Figure B.2 b\)](#) for inserts with $\kappa_r = 45^\circ$ (SN ... ANN) and checked by means of a dial gauge which has been zeroed to dimension *m* by means of a roller with the aid of a gauge block. The dial gauge then gives a direct reading of the error when applied to the inserts to be measured. The roller has a tolerance of $\pm 0,002$ mm.

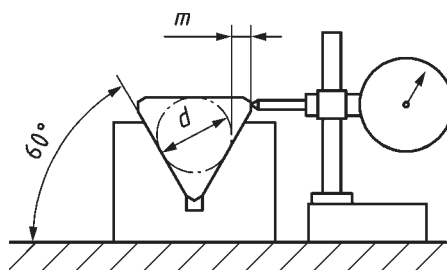

Figure B.1

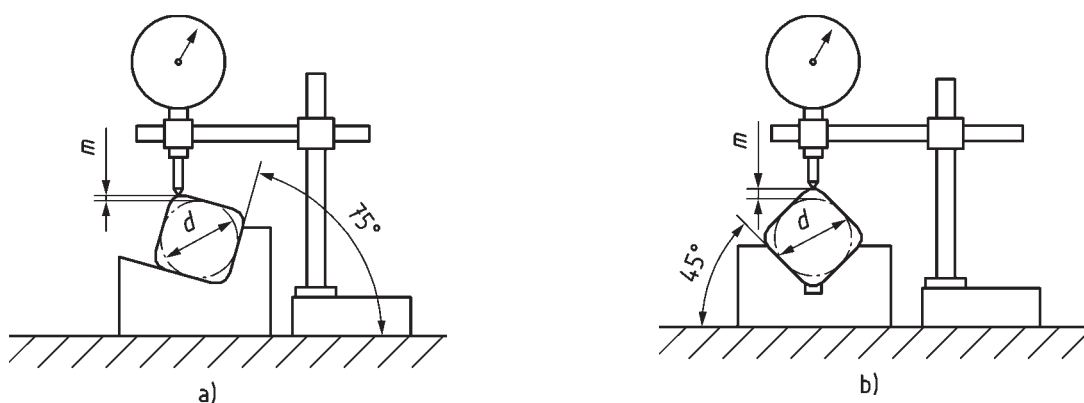

Figure B.2

Three positioning points of the insert can be useful in the block measuring dimension *m*. In this case, two such points should be on the clearance that is angle φ from the wiper edge normal clearance.

Annex C
(normative)

Range of sizes for inserts with wiper edges, without fixation hole

See [Table C.1](#).

Table C.1

Normal clearance α_n	Wiper edge normal clearance α'_n	Tolerance classes								
		A			C			K		
		Cutting edge angle κ_r								
		90°	75°	45°	90°	75°	45°	90°	75°	45°
0°	0°	—	SNAN1204 ENN	SNAN1204 ANN	—	SNCN1204 ENN	SNCN1204 ANN	—	SNKN1204 ENN	SNKN1204 ANN
			SNAN1504 ENN	SNAN1504 ANN		SNCN1504 ENN	SNCN1504 ANN		SNKN1504 ENN	SNKN1504 ANN
			SNAN1904 ENN	SNAN1904 ANN		SNCN1904 ENN	SNCN1904 ANN		SNKN1904 ENN	SNKN1904 ANN
11°	11°	TPAN1103 PPN	—	—	TPCN1103 PPN	—	—	TPKN1103 PPN	—	—
		TPAN1603 PPN			TPCN1603 PPN			TPKN1603 PPN		
		TPAN2204 PPN			TPCN2204 PPN			TPKN2204 PPN		
11°	15°	TPAN1603 PDR	SPAN1203 EDR	—	TPCN1603 PDR	SPCN1203 EDR	—	TPKN1603 PDR	SPKN1203 EDR	—
		TPAN1603 PDL	SPAN1203 EDL		TPCN1603 PDL	SPCN1203 EDL		TPKN1603 PDL	SPKN1203 EDL	
		TPAN2204 PDR	SPAN1504 EDR		TPCN2204 PDR	SPCN1504 EDR		TPKN2204 PDR	SPKN1504 EDR	
		TPAN2204 PDL	SPAN1504 EDL		TPCN2204 PDL	SPCN1504 EDL		TPKN2204 PDL	SPKN1504 EDL	
20°	20°	—	—	—	TECN1603 PER	SECN1203 EER	—	—	—	—
					TECN1603 PEL	SECN1203 EEL				

Annex D (informative)

Relationship between designations in this International Standard and ISO 13399

D.1 Relationship between designations

For relationship between designations in this International Standard and preferred symbols according to ISO 13399, see [Table D.1](#).

Table D.1 — Relationship between designations in this International Standard and ISO 13399 series

Symbol in ISO 3365	Reference in ISO 3365	Property name in ISO 13399	Symbol in ISO 13399	Reference in ISO 13399
N.N.	Clause 3	insert shape code	SC	ISO/TS 13399-2 71CE7A9F0C79F
N.N.	Clause 4	tolerance class insert	TCINS	ISO/TS 13399-2 71CE7AA215888
N.N.	7.1.1, 7.1.2, 7.1.3, 7.2.1, 7.2.2, 7.2.3, 7.2.4	clearance angle major	AN	ISO/TS 13399-2 71DD70308D3E3
N.N.	7.1.1, 7.1.2, 7.1.3, 7.2.1, 7.2.2, 7.2.3, 7.2.4	clearance angle wiper edge	AS	ISO/TS 13399-2 71DD7031A98E9
b'_s	Tables 1, 3, 5, 6, 8, 10, 12	wiper edge length	BS	ISO/TS 13399-2 71CE7AA249F88
d	Tables 1, 3, 5, 6, 8, 10, 12	inscribed circle diameter	IC	ISO/TS 13399-2 71CE7A96D9F7D
ε_r	Tables 1, 3, 5, 6, 8, 10, 12	insert included angle	EPSR	ISO/TS 13399-2 71CE7A96BC122
κ_r	Figures 1, 2, 3, 4, 5, 6 and 7	tool cutting edge angle	KAPR	ISO/TS 13399-2 71F683C9B
m	4.2 Tables 1, 3, 5, 6, 8, 10, 12	m-dimension	M	ISO/TS 13399-2 71CE7AA0972DB
l	Tables 1, 3, 5 Figures 4, 5, 6 and 7	cutting edge length	L	ISO/TS 13399-2 71DD6C95DA49B
s	Tables 1, 3, 5, 6, 8, 10, 12	insert thickness	S	ISO/TS 13399-2 71CE7A9F5308C
$\approx 0,7$ mm; 0,3 mm to 0,4 mm; ≈ 1 mm	Figures 2, 3, 4 and 5	corner chamfer length	BCH	ISO/TS 13399-2 71DD6C895C25B
45°, 37°30'	Figures 2, 3, 4 and 5	corner chamfer angle	KCH	ISO/TS 13399-2 71DD6C88F9210

Bibliography

- [1] ISO 883, *Indexable hardmetal (carbide) inserts with rounded corners, without fixing hole — Dimensions*
- [2] ISO 3364, *Indexable hardmetal (carbide) inserts with rounded corners, with cylindrical fixing hole — Dimensions*
- [3] ISO/TS 13399-2:2014, *Cutting tool data representation and exchange — Part 2: Reference dictionary for the cutting items*

