**Measurement of clean water flow in
closed conduits — Velocity-area method
using current-meters in full conduits and
under regular flow conditions**

*Mesurage de débit d'eau propre dans les conduites fermées —
Méthode d'exploration du champ des vitesses dans les conduites en
charge et dans le cas d'un écoulement régulier, au moyen de moulinets*



Reference number
ISO 3354:2008(E)

© ISO 2008

PDF disclaimer

This PDF file may contain embedded typefaces. In accordance with Adobe's licensing policy, this file may be printed or viewed but shall not be edited unless the typefaces which are embedded are licensed to and installed on the computer performing the editing. In downloading this file, parties accept therein the responsibility of not infringing Adobe's licensing policy. The ISO Central Secretariat accepts no liability in this area.

Adobe is a trademark of Adobe Systems Incorporated.

Details of the software products used to create this PDF file can be found in the General Info relative to the file; the PDF-creation parameters were optimized for printing. Every care has been taken to ensure that the file is suitable for use by ISO member bodies. In the unlikely event that a problem relating to it is found, please inform the Central Secretariat at the address given below.



COPYRIGHT PROTECTED DOCUMENT

© ISO 2008

All rights reserved. Unless otherwise specified, no part of this publication may be reproduced or utilized in any form or by any means, electronic or mechanical, including photocopying and microfilm, without permission in writing from either ISO at the address below or ISO's member body in the country of the requester.

ISO copyright office
Case postale 56 • CH-1211 Geneva 20
Tel. + 41 22 749 01 11
Fax + 41 22 749 09 47
E-mail copyright@iso.org
Web www.iso.org

Published in Switzerland

Contents

Page

Foreword.....	v
1 Scope	1
2 Normative references	1
3 Terms and symbols	2
3.1 Terms	2
3.2 Symbols	3
4 Principle	4
4.1 General	4
4.2 Measurement of the measuring cross-section	5
4.3 Measurement of local velocities	6
4.4 Location and number of measuring points in the cross-section	7
5 Description of the current-meter	9
6 Requirements for the use of current-meters	9
6.1 Selection of the measuring cross-section	9
6.2 Devices for improving flow conditions	10
6.3 Calibration of the current-meter	11
6.4 Limits of use	11
6.5 Inspection and maintenance of current-meters	13
7 Setting of current-meters into the conduit	13
7.1 Setting of current-meters	13
7.2 Mounting in a circular cross-section	13
7.3 Mounting in a rectangular cross-section	14
8 Determination of the mean axial fluid velocity by graphical integration of the velocity area	16
8.1 General	16
8.2 Circular cross-sections	16
8.3 Rectangular cross-sections	18
9 Determination of the mean axial fluid velocity by numerical integration of the velocity area	20
9.1 General	20
9.2 Circular cross-sections	21
9.3 Rectangular cross-sections	22
10 Determination of the mean axial fluid velocity by arithmetical methods	23
10.1 General	23
10.2 Log-linear method	23
10.3 Log-Chebyshev method	25
11 Uncertainty in the measurement of flow-rate	27
11.1 General	27
11.2 Sources of error in local velocity measurements	27
11.3 Sources of error in estimation of flow-rate	28
11.4 Propagation of errors	29
11.5 Presentation of results	29
11.6 Calculation of uncertainty	30
Annex A (normative) Measuring sections other than circular or rectangular sections	33
Annex B (normative) Corrections for blockage effect	38

Annex C (normative) Recommendations for the selection of the type of current-meter and mounting strut	39
Annex D (normative) Example of measuring point distribution along a radius for velocity measurement in a conduit of circular cross-section in the case of the graphical and numerical methods	41
Annex E (normative) Determination of boundary layer coefficient, m, for extrapolation near the wall	43
Annex F (normative) Definition of terms and procedures used in the uncertainty calculation	45
Annex G (normative) Student's t distribution	48
Annex H (informative) Examples of values of component uncertainties	49
Annex J (informative) Example of calculation of the uncertainty in the flow-rate measurement using current-meters	51

.....

Foreword

ISO (the International Organization for Standardization) is a worldwide federation of national standards bodies (ISO member bodies). The work of preparing International Standards is normally carried out through ISO technical committees. Each member body interested in a subject for which a technical committee has been established has the right to be represented on that committee. International organizations, governmental and non-governmental, in liaison with ISO, also take part in the work. ISO collaborates closely with the International Electrotechnical Commission (IEC) on all matters of electrotechnical standardization.

International Standards are drafted in accordance with the rules given in the ISO/IEC Directives, Part 2.

The main task of technical committees is to prepare International Standards. Draft International Standards adopted by the technical committees are circulated to the member bodies for voting. Publication as an International Standard requires approval by at least 75 % of the member bodies casting a vote.

Attention is drawn to the possibility that some of the elements of this document may be the subject of patent rights. ISO shall not be held responsible for identifying any or all such patent rights.

This International Standard was prepared by Technical Committee ISO/TC 30, *Measurement of fluid flow in closed conduits*, Subcommittee SC 5, *Velocity and mass methods*.

This third edition results from the reinstatement of ISO 3354:1988 which was withdrawn in 2003 and with which it is technically identical.

Copyright International Organization for Standardization

Measurement of clean water flow in closed conduits — Velocity-area method using current-meters in full conduits and under regular flow conditions

1 Scope

This International Standard specifies a method for the determination of the volume flow-rate in a closed conduit by means of the velocity-area method using propeller-type current-meters under the following conditions:

- a) the velocity distribution is regular (see 6.1.2);
- b) the fluid is water which is clean or considered to be clean ¹⁾;
- c) the conduit is full;
- d) the flow is steady ²⁾.

It deals in particular with the technology and calibration of propeller-type current-meters, the measurement of local velocities and the calculation of the flow-rate by velocity integration.

2 Normative references

The following referenced documents are indispensable for the application of this document. For dated references, only the edition cited applies. For undated references, the latest edition of the referenced document (including any amendments) applies.

ISO 3455, *Hydrometry — Calibration of current-meters in straight open tanks*

ISO 4006, *Measurement of fluid flow in closed conduits — Vocabulary and symbols*

ISO 5168, *Measurement of fluid flow — Procedures for the evaluation of uncertainties*

ISO 7194, *Measurement of fluid flow in closed conduits — Velocity-area methods of flow measurement in swirling or asymmetric flow conditions in circular ducts by means of current-meters or Pitot static tubes*

1) This method may be applied to other single-phase fluids but special precautions should be taken in this case.

2) The steady flows observed in conduits are in practice flows in which quantities such as velocity, pressure, density and temperature vary in time about mean values independent of time; these are actually “mean steady flows”.

3 Terms, definitions and symbols

For the purposes of this document, the terms and definitions given in ISO 4006 and the following apply.

3.1 Terms

3.1.1

current-meter

device provided with a rotor the rotational frequency of which is a function of the local velocity of the fluid in which the device is immersed

NOTE 1 This International Standard is concerned only with propeller-type current-meters, i.e. current-meters the rotor of which is a propeller rotating around an axis approximately parallel to the direction of flow.

NOTE 2 Obviously this definition does not prohibit the use of self-compensating propellers (see 6.1.5), the merit of which is, in particular, that they can be used at a rather high angle relative to the local direction of the flow. However, the use of cup-type current-meters is not allowed for the purposes of this International Standard.

3.1.2

stationary array

set of current-meters mounted on one or more fixed supports which sample simultaneously the whole measuring cross-section

3.1.3

peripheral flow-rate

the volume flow-rate in the area located between the pipe wall and the contour defined by the velocity measuring points which are closest to the wall

3.1.4

mean axial fluid velocity

ratio of the volume flow-rate (the integral over a cross-section of the conduit of the axial components of the local fluid velocity) to the area of the measuring cross-section

3.1.5

relative velocity

ratio of the flow velocity at the considered point to a reference velocity measured at the same time, which is either the velocity at a particular point (e.g. at the centre of a circular conduit) or the mean axial fluid velocity in the measuring section

3.1.6

straight length

portion of a conduit whose axis is straight, and in which the cross-sectional area and cross-sectional shape are constant; the cross-sectional shape is usually circular or rectangular, but could be annular or any other regular shape

3.1.7

irregularity

any pipe fitting or configuration of a conduit which renders the conduit different from a straight length or which produces a considerable difference in wall roughness

NOTE In the case of the method of measurement specified in this International Standard, those irregularities which create the most serious disturbances are generally bends, valves, gates and sudden widening of the cross-section.

3.1.8

hydraulic diameter

diameter equal to four times the hydraulic radius, i.e. four times the ratio of the wetted cross-sectional area to the wetted perimeter

EXAMPLE In a conduit of circular cross-section running full, the hydraulic diameter is equal to the geometric diameter.

3.1.9 index of asymmetry

(for circular ducts) ratio of the standard deviation of the mean velocities calculated along each radius (i.e. along each radial line from the pipe centre to the wall along which velocity measuring positions are located) to the mean axial fluid velocity calculated for the pipe, i.e.

$$Y = \frac{\sigma_{U_i}}{U} = \frac{1}{U} \left[\frac{\sum_{i=1}^n (U_i - U)^2}{n-1} \right]^{1/2}$$

where

U_i is the mean velocity, calculated, in accordance with the integration method agreed, from the individual point velocity measurements on the i th radius (see 8.2 and 9.2);

U is the mean axial fluid velocity calculated from all the individual point velocity measurements throughout the cross-section;

n is the number of radii along which measurements are made

3.1.10 regular velocity distribution

distribution of velocities which sufficiently approaches a fully developed velocity distribution to permit an accurate measurement of the flow-rate to be made

3.2 Symbols

Symbol	Quantity	Dimension	SI unit
A	area of the measuring cross-section	L^2	m^2
a, a'	distance along a measuring line in a rectangular cross-section from the extreme measuring point to the nearest wall	L	m
D	pipe diameter	L	m
d	propeller diameter	L	m
e	uncertainty (absolute value)	$— a$	$— a$
e_r	random uncertainty	$— a$	$— a$
e_s	systematic uncertainty	$— a$	$— a$
E	relative uncertainty	$—$	$—$
E_r	relative random uncertainty	$—$	$—$
E_s	relative systematic uncertainty	$—$	$—$
H	length of the smaller side of the cross-section of a rectangular conduit	L	m
h	distance from a given measuring point to the reference wall, in the direction parallel with the smaller side of the cross-section	L	m
k	equivalent uniform roughness	L	m
L	length of the larger side of the cross-section of a rectangular conduit	L	m

Symbol	Quantity	Dimension	SI unit
l	distance from a given measuring point to the reference wall, in the direction parallel with the larger side of the cross-section	L	m
m	boundary layer coefficient	—	—
n	frequency of rotation of a propeller	T^{-1}	r/s
p	number of measuring points along a radius (circular cross-section) or a straight line (rectangular cross-section)	—	—
q_V	volume flow-rate	L^3T^{-1}	m ³ /s
R	pipe radius	L	m
r	measuring circle radius	L	m
r^*	measuring circle relative radius, $r^* = r/R$	—	—
Re	Reynolds number	—	—
U	mean axial fluid velocity	LT^{-1}	m/s
u	mean velocity along a measurement circumference or line	LT^{-1}	m/s
v	local velocity of the fluid	LT^{-1}	m/s
v_0	local velocity of the fluid at the centre-line of the pipe	LT^{-1}	m/s
Y	index of asymmetry of the flow	—	—
y	distance from a measuring point to the nearest wall	L	m
y^*	relative interval between two measuring points, $y^* = (l_i - l_{i-1})/L$	—	—
α	polar angle of a measuring point (in a circular cross-section)	—	rad
λ	universal coefficient for pipe head loss	—	—

^a The dimensions and units are those of the quantity to which the symbol refers.

4 Principle

4.1 General

The principle of the method consists of

- a) measuring the dimensions of the measuring section, which shall be chosen to be normal to the conduit axis; this measurement is for defining the area of the cross-section (see 4.2);
- b) defining the position of the measuring points in this cross-section, where the number of measuring points shall be sufficient to permit adequate determination of the velocity distribution (see 4.3);
- c) measuring the axial component of the velocity at these measuring points;
- d) determining the mean axial fluid velocity from the preceding measurements;
- e) calculating the volume flow-rate, which is equal to the product of the cross-sectional area and the mean axial fluid velocity.

However, for certain cross-sections of particular shape, the treatment of the measurement leads directly to the flow-rate determination without a preliminary calculation of the cross-sectional area and mean axial fluid velocity (see Annex A).

The error resulting from the use of the velocity-area method is dependent, among other factors, on the shape of the velocity profile and on the number and position of the measuring points.

The method of measurement and the requirements defined in this International Standard aim at achieving (at the 95 % confidence level) an uncertainty in flow-rate not greater than ± 2 % provided that the correction for blockage effect (see 6.4.3 and Annex B) has been applied.

However, this method is valid only if the flow is not affected by excessive swirl or asymmetry; criteria are given in 6.1.2 so that an estimate can be made of whether or not the flow is regular enough for this International Standard to be applicable and whether the uncertainty lies within the required range. If not, reference should be made to ISO 7194.

In general, if any of the requirements of this International Standard are not fulfilled, this method may still be applied but the uncertainty in the flow-rate measurement will be larger.

Moreover, only circular and rectangular cross-sections are specifically dealt with in this International Standard, to cover the large majority of practical cases. Nevertheless, directions on how to proceed for certain other cross-sections of particular shape are given in Annex A.

This International Standard presents three methods for determining the mean axial fluid velocity as follows.

4.1.1 Graphical integration of the velocity area (see Clause 8)

This method consists of plotting the velocity profile on a graph and evaluating the area under the curve which is bounded by the measuring points closest to the wall. To the value thus obtained is added a term representing the peripheral flow-rate (see 3.1.3) which is calculated on the assumption that the velocity profile in this zone satisfies a power law.

For this method, the measuring points may be located at whichever positions are required in order to obtain a satisfactory knowledge of the velocity profile.

4.1.2 Numerical integration of the velocity area (see Clause 9)

The only difference between this method and the previous method (4.1.1) lies in the fact that the graphical velocity profile is replaced by an algebraic curve and the integration is carried out mathematically.

4.1.3 Arithmetical methods (see Clause 10)

The arithmetical methods assume that the velocity distribution follows a particular law; the mean velocity in the conduit is then given by a linear combination of the individual velocities measured at the locations specified by the method.

For the arithmetical methods described in Clause 10, the assumption is made that in the peripheral zone the velocity distribution follows a logarithmic law as a function of the distance from the wall.

4.2 Measurement of the measuring cross-section

4.2.1 Circular cross-sections

The mean diameter of the conduit is taken as equal to the arithmetic mean of measurements carried out on at least four diameters which are at approximately equal angles to one another in the measuring section. If the difference between the lengths of two consecutive diameters is greater than 0,5 %, the number of measured diameters shall be doubled.

4.2.2 Rectangular cross-sections

The smaller side and larger side of the conduit shall both be measured at least on each straight line passing through the measuring points. If the difference between the widths (or heights) corresponding to two successive measuring lines is greater than 1 %, the number of measured widths (or heights) shall be doubled.

4.3 Measurement of local velocities

4.3.1 General

The flow velocity at a point of the measuring section is determined by measuring the rotational frequency of a current-meter placed at that point and by entering this value in the calibration equation of the current-meter.

The current-meter rotational frequency may be obtained:

- either by counting the number of propeller rotations which occur within a predetermined period; or
- by measuring the time required by the propeller to perform a specified number of rotations.

Another method that may be used is that whereby the velocity is determined by direct measurement of the signal frequency.

For both methods, various measuring points in the cross-section may be explored simultaneously or successively (see 4.3.2 and 4.3.3).

4.3.2 Simultaneous measurements

When several current-meters are used simultaneously, the method by measuring the time requires more sophisticated counting equipment than the method by counting the number of revolutions, but it is more accurate. The latter method may actually lead to an error since if a time interval is chosen, it may not correspond to a whole number of rotations.

As local velocities are generally subject to long-term fluctuations, it is necessary to provide a sufficient period of measurement for determining the mean velocity correctly. This period of time may be determined by measuring the same flow-rate during gradually increasing intervals of time. The time of measurement, t , to be adopted shall be such that the values of the mean velocity in the cross-section, obtained for measuring times equal to t and $t + \Delta t$, shall not vary by more than x %. For example, Δt could be about 30 s and x chosen to be 0,1 %. Time, t , may vary according to the mean fluid velocity.

4.3.3 Non-simultaneous measurements

In cases where all velocity measurements points are not sampled simultaneously, it is essential that the shape of the velocity profile in the measuring cross-section remain stable and be unaffected by possible variations in the flow-rate during the measuring period. The steadiness of flow-rate shall then be checked and point velocities possibly corrected by means of a continuous measurement, during the whole duration of gauging, of the velocity at a reference point.

If only one measuring device is available, the steadiness of the flow-rate shall be checked by frequently repeating measurements at the reference point.

However, note that velocity profile fluctuations do not necessarily create flow-rate fluctuations. In such a case the use of a reference point velocity may lead to errors and it is preferable to check that the flow-rate is steady by means of any pressure-difference device (e.g. standardized or non-standardized pressure-difference flow-meter, a piezometric control on a convergence, a device on a bend, a spiral casing, a device for indicating a peculiar pressure loss) even if it is not calibrated, provided that its reliability and adequate sensitivity have been ascertained.

When the curve of the reference velocity, v_r , has been plotted against time, this curve is used to relate all velocity measurements to the same reference flow-rate, q_0 (preferably that which corresponds to the mean of the reference velocity measurements). For comparatively small changes in the reference velocity, the velocity, $v_{i,t}$, measured at any point at time, t , can be corrected by multiplying by the ratio of the reference velocity, $v_{r,0}$, corresponding to the flow-rate, q_0 , to reference velocity, $v_{r,t}$, at time, t :

$$v_{i,0} = v_{i,t} \left(\frac{v_{r,0}}{v_{r,t}} \right)$$

where $v_{i,0}$ is the velocity at point i to be used for the integration.

4.3.4 Checking the velocity distribution

Even when the mean axial fluid velocity is calculated by a method which does not require plotting of the velocity profile, it is recommended, in order to be confident that the velocity distribution is regular, that this plotting be carried out, or at least that its regularity be checked by some other means.

In the same way, when several measurements are made on the same cross-section at different flow-rates, it is recommended that the velocity profiles be plotted in a non-dimensional manner [i.e. by using the relative velocities (see 3.1.5)] to check their consistency with one another and hence to ensure that there are no abnormal features at particular flow-rates (thus, the profiles shall not change erratically as the flow-rate varies over a wide range of Reynolds numbers).

It may also be useful to plot the velocity distribution curves as indicated above in order to detect any error in the measurement of a local velocity. The doubtful measurement shall be repeated whenever possible; when this cannot be done, it shall be rejected and the velocity profile drawn on the basis of the remaining data, provided that there are independent reasons for believing that the doubtful measurement is false.

4.4 Location and number of measuring points in the cross-section

4.4.1 General

The location of the measuring points depends on the method chosen to calculate the flow-rate. The rules relating to the methods specified in this International Standard are given in Clauses 8, 9 and 10.

Whatever the method, the following dimensional rules shall be complied with:

- the minimum distance between the current-meter axis and the wall shall be $0,75d$;
- the minimum distance between the axes of two current-meters shall be $(d_1 + d_2)/2 + 0,03$ m, where d_1 and d_2 are the outside diameters of the propellers of the current-meters.

NOTE Usually, d_1 and d_2 are equal, but it can be useful to set current-meters having propellers smaller in diameter than those used at other locations in the cross-section in the vicinity of the wall to explore best the flow pattern in this area (see Clause 8).

The location of any current-meter shall be measured to the smaller of the following two uncertainties:

- $\pm 0,01 L$, where L is the dimension of the conduit parallel to the direction of measurement of the current-meter position;
- $\pm 0,02 y$, where y is the distance of the current-meter from the nearest wall.

The minimum number of measuring points, applying in particular to small-dimension conduits, is specified in 4.4.2 and 4.4.3. As it is necessary that the velocity profile be known as accurately as possible, it may be advantageous to increase the number of measuring points provided that this is allowed by the requirements given above and that it does not cause notable blockage effects (see 6.4.3).

When a single current-meter is traversed across a conduit, it is first necessary to determine the distance between a reference point (from which each position is measured) and the wall of the duct. This may introduce a relatively large systematic error in all position measurements. In such circumstances it is recommended, in the case of a circular cross-section conduit, that complete diameters be traversed (rather than opposite radii on each diameter) since the systematic error will then tend to cancel out on the two halves of the traverse. However, blockage and vibration problems may be more severe when a complete diameter is traversed.

4.4.2 Circular cross-sections

The measuring points on circular cross-sections shall be located at every point of intersection between a given number of circles concentric with the pipe axis and a given number of diameters at equal angular spacing.

The minimum numbers recommended in the scope of this International Standard are three circles and two mutually perpendicular diameters (see last paragraph) so that the minimum number of measuring points in the cross-section is 12. An additional measuring point at the centre of the conduit is desirable to check the shape of the velocity profile.

However, this minimum number is acceptable only if one of the following conditions is fulfilled:

- if it is known that the velocity distribution is very nearly axisymmetrical, which is checked either by examining the layout of the pipe or by measurements previously carried out in the same cross-section, or
- if the use of a higher number of diameters results in a prohibitive blockage of the measuring section (see 6.4.3).

If neither of these conditions is fulfilled, the velocity distribution shall be scanned more closely, e.g. by increasing to three the number of diameters. It should be noted that in general the uncertainty in flow measurement is reduced more by increasing the number of radii along which measurements are made than by increasing the number of points per radius; nevertheless, there is little advantage in exceeding four diameters.

When the measurements are carried out by means of a stationary array, reference should be made to 6.4.4 for the minimum diameter of conduits in which this method can be applied; however, in any case the general requirements given in 4.4.1 on the minimum distance between two current-meters prohibit the use of a stationary array in conduits the diameter of which is less than $7,5 d + 0,18$ m.

If a high accuracy is not required, measurements may be made along a single diameter provided that there is a straight length of at least $60 D$ upstream of the measurement section and provided that the Reynolds number is in excess of the values given in Table 1 for the corresponding values of the universal coefficient for pipe head loss λ . (For the estimation of λ , see Annex E.)

Table 1 — The minimum Reynolds number as a function of the universal coefficient for pipe head loss, λ

λ	Re_D
$\geq 0,03$	10^4
0,025	3×10^4
0,02	10^5
0,01	10^6

4.4.3 Rectangular cross-sections

The minimum number of measuring points shall be 25. Unless a special layout of measuring points is adopted for the use of an arithmetical method, their position shall be defined by the intersections of at least five straight lines running parallel to each of the boundaries of the cross-section.

When the measurements are carried out by means of a stationary array, reference should be made to 6.4.4 for the minimum dimensions of conduits in which this method can be applied; however, in any case the general requirements given in 4.4.1 on the minimum distance between two current-meters prohibit the use of a stationary array in conduits the smaller dimension of which is less than $5,5 d + 0,12$ m.

5 Description of the current-meter

A propeller-type current-meter consists of a propeller, an axis of rotation, bearings and the current-meter body with the counting device.

Each current-meter may be fitted with different types of propeller (e.g. of different pitch, diameter). Propellers may have two or more blades and may be manufactured out of metal or plastics material.

Current-meters for site measurements shall be manufactured out of non-corrosive material only or shall be effectively protected against corrosion. They shall be of sufficiently sturdy construction for their calibration to remain valid under normal field operating conditions.

Components shall be interchangeable to allow easy replacement of worn or damaged parts, but this replacement shall not increase the uncertainty in the measurement.

Output signals may be generated by mechanical contact or by any magnetic, electrical or optical device. They are totalized or recorded on an appropriate receiver or indicated by an acoustic or optical device.

Counting shall be accurate and reliable for any given velocity within the operational range specified by the manufacturer. The number of signals delivered per propeller revolution shall be consistent with the velocities to be measured, the design of the receiver and an acceptable measuring period. In some cases, it will therefore be necessary to be able to choose the number of signals per propeller revolution.

Provision shall be made for fixing the current-meter on a support in a well-defined position.

6 Requirements for the use of current-meters

6.1 Selection of the measuring cross-section

6.1.1 The cross-section selected for the measurements shall be located in a straight length; it shall be perpendicular to the direction of flow and of simple shape, e.g. circular, rectangular. The measuring cross-section shall be located in an area where the individual local velocities fall within the normal working range of the current-meters used (see 6.4.2).

6.1.2 Close to the measuring cross-section, the flow shall be such that it may be considered to be "regular", i.e. it shall be substantially parallel to and symmetric about the conduit axis and shall present neither excessive turbulence nor swirl. (For further information, see ISO 7194.)

The flow may be assumed to be sufficiently regular to permit the use of this International Standard if the two following conditions are fulfilled:

- a) at any point of the cross-section, the swirl angle shall be less than or equal to 5° ;
- b) the index of asymmetry, Y (as defined in 3.1.9), shall be less than or equal to 0,05.

As a guide, it can be assumed that a bulk swirl of the flow has no appreciable effect on the confidence limits given in this International Standard for the flow-rate measurement so long as it results in a deviation in the local velocity with respect to the pipe axis of less than 5°. An index of asymmetry, $Y = 0,05$, corresponds approximately to a component uncertainty in the flow-rate arising from the asymmetry of the velocity distribution of about 0,35 %, provided that the measuring cross-section is traversed along at least six radii.

6.1.3 For these requirements to be met, the measuring cross-section shall be chosen to be far enough away from any disturbances that could create asymmetry, swirl or turbulence. The length of straight pipe that may be required will vary with the flow velocity, upstream disturbances, wall roughness, the level of turbulence and the degree of swirl, if any.

As a guide, it has often be assumed that there should be a straight length of conduit between the measuring cross-section and any important irregularity upstream (see 3.1.7) of at least 20 times the hydraulic diameter of the conduit (see 3.1.8). Similarly, there should be a straight length of at least five times the hydraulic diameter of the conduit between the measuring cross-section and any important downstream irregularity. These values have been generally acceptable in the past since conduits had comparatively rough walls. However, with the use of very smooth modern linings, having lower hydraulic roughness, and the use of conduits larger and larger in diameter, particular care needs to be taken when estimating the necessary straight lengths.

Furthermore, special consideration is necessary when the upstream irregularity (e.g. bends in different planes) is such that it can give rise to a swirl of the flow, which is always very slow to disappear.

6.1.4 If there is any doubt about the flow conditions, it is necessary to make preliminary traverse tests to ascertain the regularity of flow.

If these traverses show that the flow is not satisfactory, i.e. that it does not fulfil the conditions defined in 6.1.2, reference shall be made to ISO 7194 for carrying out the flow measurement. Note, however, that the asymmetry of the velocity distribution is taken into account in some measure by the very principle of the velocity-area method and that it increases only slightly (normally less than ± 1 % if Y is not greater than 0,25) the inaccuracy of the measurements provided that the number of measuring points is adequate, whereas swirl affects every measurement of local velocity.

6.1.5 Although measurements with current-meters in oblique or converging flow shall as far as possible be avoided, they may be carried out if one of the following conditions is fulfilled:

- a) the current-meters used are designed to measure accurately the true axial component of the velocity, this being checked by an appropriate calibration up to the expected maximum velocity;
- b) the maximum flow deviation with respect to the current-meter axis does not exceed 5°.

NOTE Commonly used propellers may give correct indications up to angles of incidence of 5° with an accuracy of 1 % (relative deviation between the measured velocity and the axial component of the flow velocity). There exist self-compensating propellers which measure directly the axial component of velocity with an error smaller than 1 % for greater angles of incidence, but it is necessary to consider the particular sensitivity of such propellers to the influence of the current-meter support (especially the angle of the plane containing the velocity vector and the current-meter axis to the plane containing the current-meter support and axis) and to the flow turbulence.

6.2 Devices for improving flow conditions

If the velocity distribution is too irregular or the flow is not sufficiently parallel, but it is known that no swirl exists in the flow, it is sometimes possible to remedy these irregularities by means of a guiding installation. This consists of a slightly converging entrance connected, without creating any separation, to a straight pipe length, the length of which is, if possible, at least equal to twice the larger dimension of the conduit. It shall be ensured by calculation that the current-meters closest to the wall are within the boundary layer, the thickness of which is given by $\delta = 0,37x(Ux/\nu)^{-0,2}$, and that the procedures for evaluating the peripheral flow apply. If this is not the case, the velocity shall be assumed not to vary between the current-meter closest to the wall and the boundary layer, and the peripheral flow shall be calculated in the boundary layer only. If arithmetical integration is used, it shall be checked, for at least one flow measurement, that no abnormal deviation exists

with respect to graphical or numerical integration. It should, however, be noted that the installation of such a device may modify the flow-rate value.

6.3 Calibration of the current-meter

6.3.1 The calibration of a current-meter requires the empirical determination of the relationship between the water velocity and the propeller velocity. This relationship is generally represented by one or several straight lines given by the equation

$$v = an + b$$

where

v is the velocity, in metres per second, of the water;

n is the rotational frequency, in revolutions per second, of the propeller;

a and b are constants to be determined by calibration.

6.3.2 Calibration shall be carried out in an installation specially designed for this purpose in conformity with the specifications of ISO 3455.

6.3.3 For calibration, the current-meter shall be fitted with the same support as that used for measurements.

6.3.4 Each current-meter shall be recalibrated at regular intervals depending on the conditions of use. As a guide, these intervals are usually of a few hundred hours of operation in water of normal quality. However, after a series of measurements, it is essential to check the calibration of a current-meter, the propeller or the bearings of which appear to have been damaged (due to shocks, corrosion, abrasion, etc.). A recalibration is also necessary if any component of the current-meter is changed.

6.3.5 In principle, each current-meter shall be calibrated individually. However, if the propellers of a series of current-meters are dimensionally consistent and interchangeable and if a first calibration has proved the hydraulic similitude of the propellers, statistical calibration equations may be derived from a sufficient number of individual calibrations under well-defined conditions. In this case, the calibrating organization shall indicate the maximum probable deviations from the mean calibration equation proposed.

6.4 Limits of use

6.4.1 Nature of the liquid

Current-meters shall not be used when their performance may be disturbed by dissolved or suspended matters in the water in the conduit.

6.4.2 Range of velocities

Current-meters shall only be used within their normal range of use, i.e. the range of velocities for which they have been calibrated; extrapolation towards higher velocities may nevertheless be permitted up to 1,25 times the maximum calibration velocity in the case when calibration cannot be achieved at those higher velocities.

However, the calibration curve shall never be extrapolated into the area of lower velocities where the accuracy and above all the repeatability of current-meters decrease considerably. As a general rule, no current-meter shall be used at velocities less than a certain threshold below which the lack of repeatability may lead to important errors (the threshold is a function of the current-meter type; it is less than 0,5 r/s for well-maintained current-meters).

6.4.3 Blockage effect

The velocity distribution in the conduit is disturbed by the current-meters and their support(s) and this leads to a positive error being made in the flow-rate measurement.

Theoretical and experimental studies have shown that the magnitude of this error is dependent on:

- a) the number, the profile and the frontal area of the support struts (and where applicable of the central junction piece);
- b) the distance between the active part of the propeller and the support strut;
- c) the type, the number and the size of the current-meters used (e.g. the size of the propeller, hub, body).

In general, however, it has been found that the relative blockage of the main support cross with respect to the measuring section, i.e. the ratio of the frontal area of the support cross to the total cross-sectional area of the conduit, is the most important geometrical parameter. If this relative blockage is between 2 % and 6 %, a correction shall be made (see Annex B); if it is greater than 6 %, the measurement cannot be made in accordance with this International Standard.

6.4.4 Dimensional restrictions

The remarks on the blockage effect (see 6.4.3) on the one hand, and the dimensional requirements specified in 4.4.1 on the other hand, prohibit measurements by means of current-meters in conduits the dimensions of which are too small compared with those of the current-meters used. Thus current-meters and support struts shall be chosen such that their dimensions are suitable for those of the conduit in which the measurement is to be made.

In general, it is accepted that a fixed current-meter array may be used if the diameter of a circular cross-section conduit is greater than $9d$ or if the smaller side of a rectangular cross-section is greater than $8d$, provided that the relative blockage as defined in 6.4.3 is less than 6 %. (See also 4.4.2 and 4.4.3.)

Thus, for example, for those types of current-meter and support cross that are commonly used for industrial measurements and which have propellers with diameters in the range 0,100 m to 0,125 m, it is generally accepted in practice [taking account of the general requirements on the minimum distance between two current-meters on the one hand (see 4.4.2) and of the blockage due to the support on the other hand] that a stationary array mounted on cross-bars may be used only in circular conduits of diameters greater than 1,4 m. In a rectangular cross-section, it is also agreed that the smaller dimension of the conduit (to which the support struts are parallel) shall be at least equal to 1 m, and furthermore that the larger dimension shall be sufficient to limit the blockage effect (see 6.4.3).

When the flow-rate has to be calculated using an arithmetical integration method (see Clause 10), the locations prescribed for the current-meters and in particular for those which are closest to the wall result in noticeably higher minimum values of D/d or H/d (e.g. $D/d > 23$ for a measurement method with three points per radius in a circular cross-section).

In conduits with smaller dimensions, current-meters fitted with smaller propellers (e.g. ranging from about 0,03 m to 0,05 m in diameter) or even micro-current-meters mounted on a frame as light as possible may be used. Alternatively a device, often complex in design, which enables non-simultaneous measurements to be made may also be used (see 7.2.2, 7.2.3 or 7.3.2).

6.4.5 Influence of turbulence and velocity fluctuations

Although the influence of longitudinal and transverse components of flow turbulence on current-meter behaviour is still incompletely defined, attention is drawn to the fundamental difference between the behaviour of current-meters being calibrated by hauling in stagnant water and current-meters being used in turbulent flow conditions. Longitudinal fluctuations lead to a positive error in the velocity measured by means of the current-meter whereas transverse fluctuations generally lead to a negative error. While bearing in mind that many factors influence a current-meter response, it may be observed that the error will increase as:

- the fluctuation amplitude and frequency increase;
- the mean velocity decreases; and
- the moment of inertia of the propeller increases.

6.5 Inspection and maintenance of current-meters

6.5.1 Inspection

The condition of the current-meter shall be checked before and after each measurement, in particular for:

- a) free rotation in bearings;
- b) absence of propeller deformation;
- c) correct functioning of the rotational frequency detection device.

The inspection for friction in the bearings may be carried out by observing how the propeller slows down after having been spun at a certain speed. In no case shall the propeller stop abruptly.

The propeller shape may be checked by means of a plaster mould or by means of a metal profile template.

6.5.2 Maintenance

After each series of measurements, the current-meter shall be dismantled, carefully cleaned, and then re-lubricated using the same lubricant as was used for calibration.

7 Setting of current-meters into the conduit

7.1 Setting of current-meters

Current-meters shall be fixed rigidly on the mounting strut in such a way that the propeller axis is perpendicular to the measuring section plane to within 2°.

The mounting struts of a stationary array shall themselves be rigidly connected to the conduit walls. They shall be designed to offer sufficient mechanical strength (in particular to avoid any prejudicial vibration), minimum and stable drag, and minimum interference with the current-meter operation.

Guidelines on the shape of the mounting struts are given in Annex C.

7.2 Mounting in a circular cross-section

7.2.1 Stationary array

Current-meters are generally used as stationary arrays. Mounting struts shall therefore be arranged along the conduit radii so as to form at least two diameters (see 4.4.2); an example of this arrangement is given in Figure 1. As far as possible, no measuring arm shall be located in the vertical plane of the pipe axis to avoid possible effects of air pockets or sediment load. Blockage on the centre-line can be reduced by cantilevering the radial supporting arms from the conduit wall; if this is done, only a single diameter passing actually through the centre of the conduit is needed.

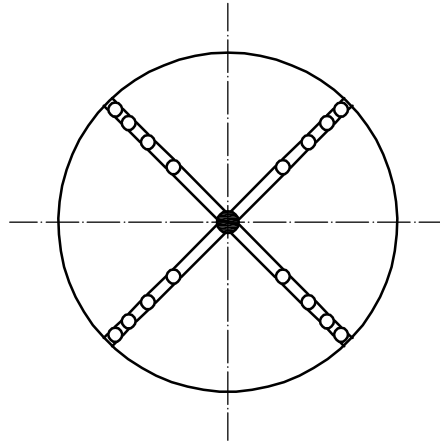

Figure 1 — Stationary array of current-meters mounted on cross-bars in a circular conduit

7.2.2 Rotating arm

Current-meters may be fixed along a diameter rotating around the cross-section axis. (An example of this arrangement is given in Figure 2.) This sophisticated device (rotation is controlled from the outside and vibration risks are to be avoided) allows the scanning of a far greater number of measuring points.

It may, if required, allow direct measurement of the mean velocity per circumference, the integration along each circle being obtained by making the diameter rotate at a constant speed. The maximum tangential speed of the rotating diameter shall not exceed 5 % of the mean flow velocity.

In order to ensure that the measurement is not falsified by an excessive angle of the apparent velocity with respect to the current-meter, owing to the combination of the current-meter movement and a preexisting obliqueness or swirl of the flow, it is recommended that the measurements made by continuous integration be checked either by rotating the rotating arm in the reverse direction or by making measurements with the arm positioned at a number of fixed locations.

7.2.3 Exploration by means of a single current-meter

A current-meter may be used in isolation by placing it successively at each measuring point. This method requires special equipment (lock-vanes) which enables the current-meter mounting strut to be guided along the scanned diameter and to be transferred from one measuring diameter to the next, while maintaining the water-tightness. In addition, account shall be taken of the requirements given in 4.3.2.

7.3 Mounting in a rectangular cross-section

7.3.1 Stationary array

Current-meters may be used as a stationary array mounted on a number of parallel struts. This method may result in a significant obstruction of the cross-section by the supports.

7.3.2 Exploration of a section by means of a row of current-meters

Another method consists of using a sliding rest bearing one (or two) row(s) of current-meters, travelling in such a way that the current-meters are successively placed on all horizontal measuring lines (or alternatively on all vertical lines). This device requires external control with water-tight sealing of certain parts. In addition, account shall be taken of the requirements given in 4.3.2.

This process may allow direct measurement of the mean velocity along one vertical (or one horizontal), the integration along each vertical (or horizontal) line being obtained by constant-speed displacement of the slide rest. This speed shall not exceed 5 % of the mean flow velocity.

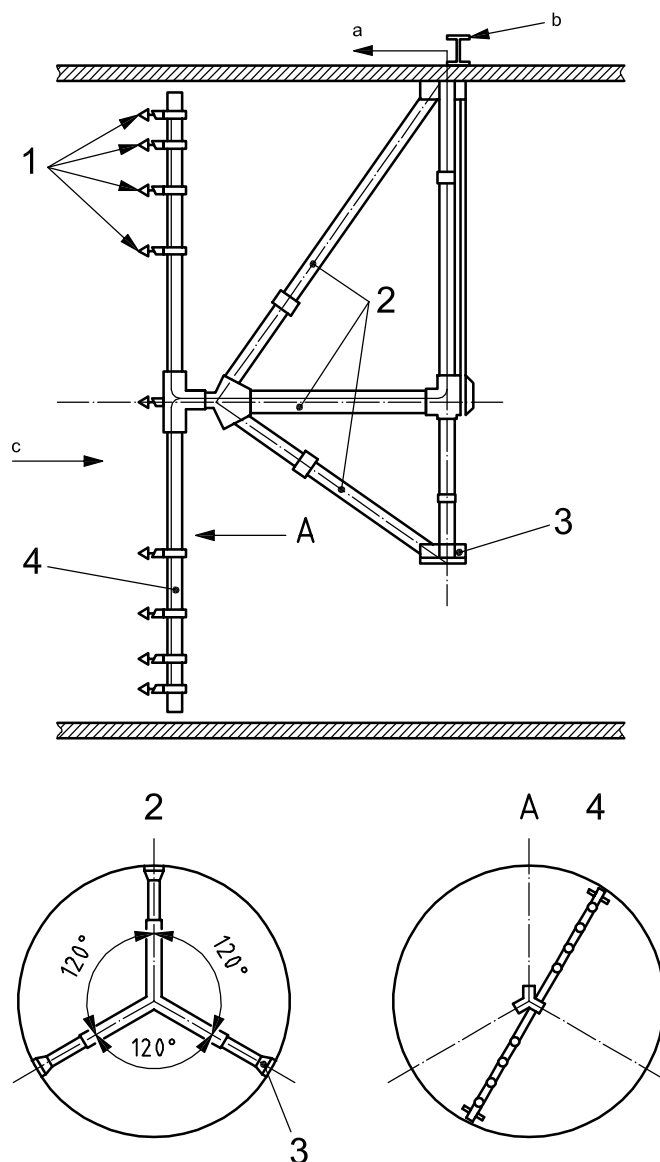

Key

- 1 current-meter
- 2 tripod support
- 3 attachment at wall
- 4 rotating arm

- a To the recorder.
- b Driving gear of rotating arm.
- c Direction of flow.

Figure 2 — Diametral arm device rotating in a circular conduit

In order to ensure that the measurement is not falsified by an excessive angle of the apparent velocity with respect to the current-meter, owing to the superposition of the current-meter movement and a preexisting obliqueness or swirl of the flow, it is recommended that the measurements made by continuous integration be checked either by moving the slide in the reverse direction or by making measurements with the slide positioned at a number of fixed locations.

However, in the case of flow for which the piezometric line is only slightly above the top of the conduit, the application of this procedure is simplified: the slide device can be moved in wells or grooves (e.g. bulkhead grooves) opening to the atmosphere and its control device can be located above the maximum water-level.

8 Determination of the mean axial fluid velocity by graphical integration of the velocity area

8.1 General

The general principle of this method is specified in 4.1.

The measuring points shall be located along straight lines. The measuring points at the ends of each of these lines (the extreme measuring points) shall be located as close as possible to the wall and the adjacent measuring points shall be located sufficiently close to the extreme measuring points to ensure an accurate determination, in the manner prescribed in Clause E.1, of the boundary layer coefficient, m , appearing in the law used for describing the flow in the peripheral zone.

The number and position of the other points shall be selected in such a way that the velocity profile can be determined satisfactorily. Usually, these points should be distributed in the cross-section in such a way as to divide it into areas, each of which is expected to have the same flow-rate, in order to attach approximately the same importance to all measuring points.

An example of the measuring point distribution for a circular cross-section for which no indication on the velocity distribution is available is given in Annex D.

In general, reference shall be made to 4.4 to determine the number and location of measuring points.

8.2 Circular cross-sections

The mean axial fluid velocity U is given by the equation

$$\begin{aligned}
 U &= \frac{1}{\pi R^2} \int_0^{2\pi} \int_0^R v(r, \alpha) r \, dr \, d\alpha \\
 &= \int_0^1 u \, d\left(\frac{r}{R}\right)^2 \\
 &= \int_0^{(r_p/R)^2} u \, d\left(\frac{r}{R}\right)^2 + \int_{(r_p/R)^2}^1 u \, d\left(\frac{r}{R}\right)^2
 \end{aligned}$$

where

- v is the flow velocity at a point having the polar coordinates r and α ;
- u is the mean velocity along the circumference of radius r ;
- R is the mean radius of the measuring section (see 4.2.1);
- r_p is the radius of the circle defined by the measuring points closest to the wall.

The determination of the mean axial fluid velocity U is carried out as follows.

- a) Take u_c (the arithmetic mean of the velocities at the measuring points located on a circle of radius, r_c) as the value of u^3)

- 3) Some experimental devices allow direct measurement of the mean velocity along a circumference (see 7.2.2).

- b) Plot the curve of the variation in u_c against $(r_c/R)^2$ between $r = 0$ and $r = r_p$ ⁴⁾ (see Figure 3).
- c) Determine graphically the value of the area below this curve between $r = 0$ and $r = r_p$.
- d) Add to this value a calculated term⁵⁾ corresponding to the peripheral zone and equal to

$$\left(\frac{m}{m+1}\right)u_p \left(1 - \frac{r_p^2}{R^2}\right)$$

where

- u_p is the value of the arithmetic mean of the velocities at the measuring points located on the circle of radius, r_p (i.e. closest to the wall);
- m is a coefficient depending on the wall roughness and on the flow conditions, the value of which can be determined in accordance with the method given in Annex E, and is generally between 4 (rough wall at low Reynolds numbers) and 14 (smooth wall at high Reynolds numbers).

The method is applicable when current-meters are not located exactly on circumferences (owing to, for example, mounting errors and practical unfeasibility). Integration is then carried out radius after radius by considering the actual position of each current-meter and then arithmetically averaging the elementary flow-rates per radius.

-
- 4) To facilitate plotting of the curve in the vicinity of the measuring point closest to the wall, draw the tangent to the curve for $r = r_p$ with a slope equal to

$$\left(\frac{du_c}{dx}\right)_{r=r_p} = \frac{-u_p}{2m \frac{r_p}{R} \left(1 - \frac{r_p}{R}\right)}$$

denoting $(r/R)^2$ as x . The slope of the curve is derived from Karman's conventional law for the variation in the fluid velocities in the peripheral zone:

$$u = u_p \left(\frac{R-r}{R-r_p}\right)^{1/m}$$

- 5) This simplified expression omits the other term

$$\frac{-m}{(m+1)(2m+1)}u_p \left(1 - \frac{r_p}{R}\right)^2$$

in the result of the integration (within the peripheral zone) derived from Karman's conventional law: this latter term represents only about $\frac{1 - (r_p/R)}{(4m+2)}$ times the flow in the peripheral zone.

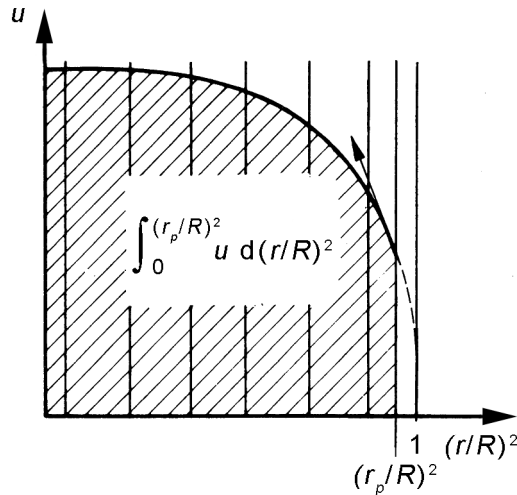

Figure 3 — Computation of the mean axial fluid velocity in a circular conduit — Graphical integration in the area scanned by the current-meters

8.3 Rectangular cross-sections

The computation of the mean axial fluid velocity shall be carried out by making a double integration across both dimensions of the conduit. Measurement shall be started either on the vertical lines or on the horizontal lines.

NOTE Throughout this sub-clause, a “vertical line” will mean a line parallel to the smaller dimension of the cross-section of the conduit and a “horizontal line” will mean a line parallel to the longer dimension of the cross-section of the conduit.

The method of determination is developed here starting with horizontal line measurements.

The equation for the mean axial fluid velocity is as follows:

$$U = \int_0^1 \int_0^1 v \frac{dh}{H} \frac{dl}{L}$$

where

- h is the height of the point considered above the bottom of the conduit;
- H is the conduit height at the measuring cross-section (arithmetic mean of the heights measured in accordance with 4.2.2);
- l is the distance from the point considered to the side wall chosen as origin;
- L is the conduit width at the measuring cross-section (arithmetic mean of the widths measured in accordance with 4.2.2).

The determination of the mean axial fluid velocity is carried out as follows.

- a) Plot the curve of the variation in the velocity on each horizontal line between the extreme measuring points, as a function of the relative distance l/L (see Figure 4)⁶⁾.
- b) Determine graphically the value of the area below this curve between the extreme measuring points.
- c) Add to this value two terms corresponding to the peripheral zones and equal to

$$\frac{m}{m+1} \left(\frac{a}{L} \right) v_a$$

where

m is a coefficient depending on the wall roughness and on the flow conditions, the value of which can be determined in accordance with the method given in Annex E, and is generally between 4 (rough wall at low Reynolds numbers) and 14 (smooth wall at high Reynolds numbers);

v_a is the velocity at the extreme measuring point considered (at a distance a from the nearest wall).

The sum so obtained is the mean velocity, u_i , on the horizontal measuring line concerned⁷⁾.

- d) Plot the curve of the variation in u_i , between the extreme (upper and lower) horizontal measuring lines as a function of the relative height, h_i/H , of the corresponding horizontal line (see Figure 4)⁸⁾.
- e) Determine graphically the value of the area below this curve between the extreme horizontal measuring lines.
- f) Add to the value obtained in e) two terms corresponding to the peripheral zones in order to obtain the mean axial fluid velocity. Both terms are equal to

$$\frac{m}{m+1} \left(\frac{a'}{H} \right) u_{a'}$$

where $u_{a'}$ is the mean velocity on the horizontal measuring line closest to the wall (at a distance a' from the wall).

6) To facilitate plotting in the vicinity of the extreme measuring points, the tangent to the curve at each of these points is drawn with a slope the absolute value of which is equal to $v_a L / ma$.

The slope of the curve is derived from Karman's conventional law for the variation in the fluid velocities in the peripheral zone:

$$v_y = v_a \left(\frac{y}{a} \right)^{1/m}$$

7) Some experimental devices allow direct measurement of the mean velocity along a horizontal (or vertical) line (see 7.3.2).

8) To facilitate plotting in the vicinity of the peripheral zones, the same procedure is followed as for the determination of the mean velocity along each horizontal line [see 8.3 a)].

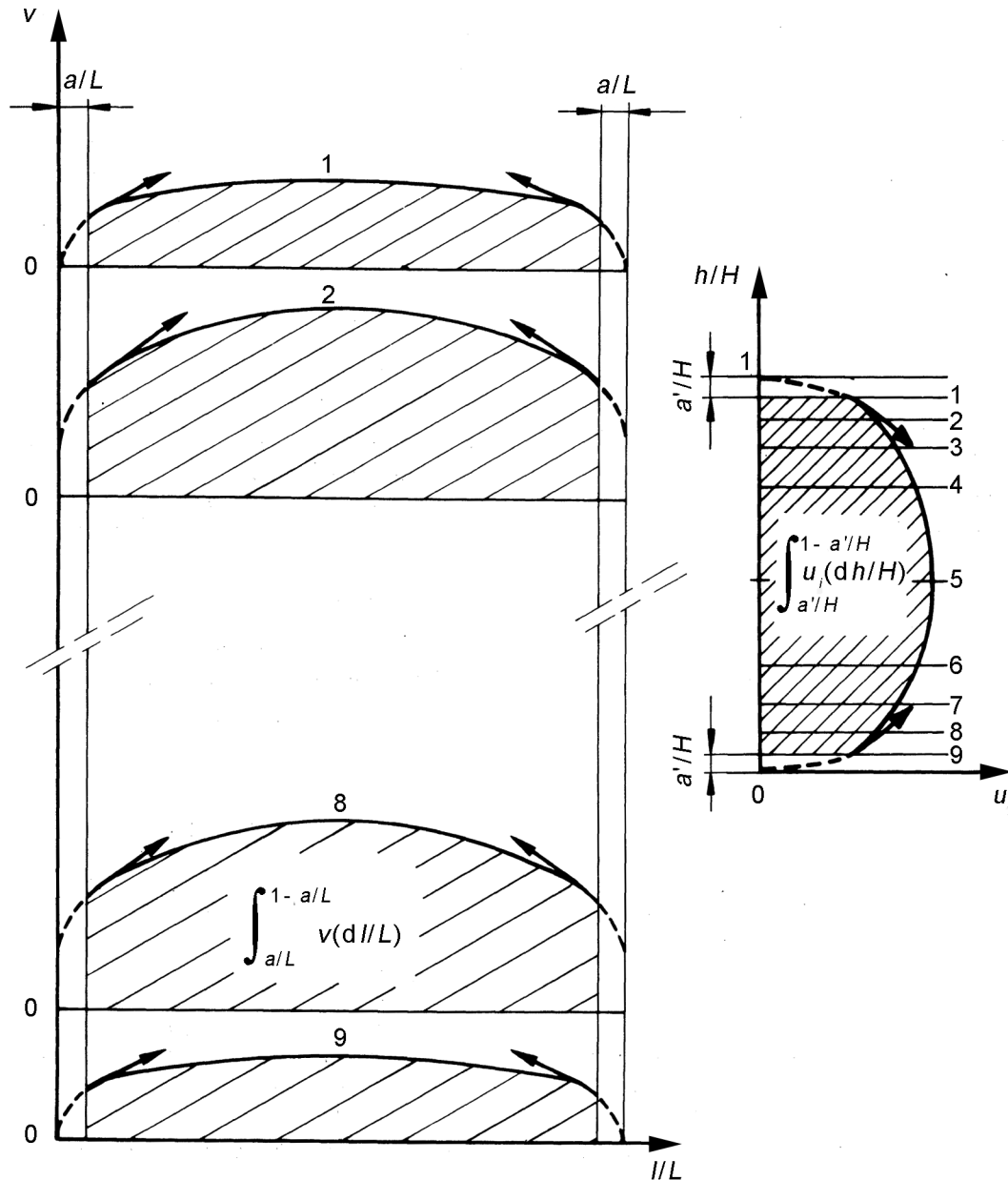

Figure 4 — Computation of the mean axial fluid velocity in a conduit of rectangular cross-section — Graphical integration in the area scanned by current-meters

9 Determination of the mean axial fluid velocity by numerical integration of the velocity area

9.1 General

The general principle of this method is laid down in 4.1.

The equations proposed below are derived from interpolations between successive pairs of measuring points along third-degree curves in $(r/R)^2$ for circular cross-section conduits, and in l/L or h/H for rectangular cross-section conduits. The different individual arcs combine to form a continuous curve with a continuous derivative.

In the peripheral zone the same laws as indicated in Clause 8 are applied.

For the number and position of measuring points, reference shall be made to the specifications of Clause 8.

9.2 Circular cross-sections

The mean axial fluid velocity U is given by the following formula:

$$\begin{aligned}
 U = & v_0 \left[-\frac{1}{12} r_2^{*2} + \frac{5}{12} r_1^{*2} + \frac{r_1^{*3}}{12 r_2^*} \right] + u_1 \left[\frac{1}{6} r_1^{*2} + \frac{2}{3} r_2^{*2} - \frac{1}{12} r_3^{*2} \right] - u_2 \left[\frac{r_1^{*3}}{12 r_2^*} \right] + \\
 & \sum_{i=2}^{p-2} u_i \left[-\frac{1}{12} r_{(i+2)}^{*2} + \frac{2}{3} r_{(i+1)}^{*2} - \frac{2}{3} r_{(i-1)}^{*2} + \frac{1}{12} r_{(i-2)}^{*2} \right] + u_{(p-1)} \left[\frac{1}{2} r_p^{*2} + \frac{1}{12} r_{(p-1)}^{*2} - \frac{2}{3} r_{(p-2)}^{*2} + \frac{1}{12} r_{(p-3)}^{*2} \right] + \\
 & u_p \left\{ \frac{m}{m+1} \left(1 - r_p^{*2} \right) + \frac{\left[r_p^{*2} - r_{(p-1)}^{*2} \right]^2}{12m \left(1 - r_p^{*2} \right)} + \frac{7}{12} r_p^{*2} - \frac{2}{3} r_{(p-1)}^{*2} + \frac{1}{12} r_{(p-2)}^{*2} \right\} \quad (A)
 \end{aligned}$$

where

v_0 is the velocity at the conduit centre;

u_1, u_2, \dots, u_p are the mean velocities [calculated as shown in 8.2a) along the circumferences with increasing relative radii, $r_1^*, r_2^*, \dots, r_p^*$ (where $r_i^* = r_i / R$ and R is the radius of the cross-section).

NOTE When $p = 3$, the summation term disappears and Equation (A) is simplified as follows:

$$\begin{aligned}
 U = & v_0 \left[-\frac{1}{12} r_2^{*2} + \frac{5}{12} r_1^{*2} + \frac{1}{12} \frac{r_1^{*3}}{r_2^*} \right] + u_1 \left[\frac{1}{6} r_1^{*2} + \frac{2}{3} r_2^{*2} - \frac{1}{12} r_3^{*2} \right] + u_2 \left[-\frac{1}{12} \frac{r_1^{*3}}{r_2^*} - \frac{2}{3} r_1^{*2} + \frac{1}{12} r_2^{*2} + \frac{1}{2} r_3^{*2} \right] + \\
 & u_3 \left[\frac{m}{m+1} \left(1 - r_3^{*2} \right) + \frac{\left(r_3^{*2} - r_2^{*2} \right)^2}{12m \left(1 - r_3^{*2} \right)} + \frac{7}{12} r_3^{*2} - \frac{2}{3} r_2^{*2} + \frac{1}{12} r_1^{*2} \right]
 \end{aligned}$$

When $p = 4$, the summation term of Equation (A) is evaluated only for $i = 2$.

Table D.1 gives the values of weighting coefficients for u_i in the particular case of the measuring point distribution defined in Clause D.1.

9.3 Rectangular cross-sections

The velocity, U , is given by the following equation:

$$U = v_1 \left[\frac{m}{m+1} y_1^* + \frac{1}{12m} \frac{y_2^{*2}}{y_1^*} + \frac{7}{12} y_2^* - \frac{1}{12} y_3^* \right] + v_2 \left[\frac{1}{2} y_2^* + \frac{7}{12} y_3^* - \frac{1}{12} y_4^* \right] + \sum_{i=3}^{p-2} v_i \left[\frac{7}{12} (y_{(i+1)}^* + y_i^*) - \frac{1}{12} (y_{(i+2)}^* + y_{(i-1)}^*) \right] + v_{(p-1)} \left[\frac{1}{2} y_p^* + \frac{7}{12} y_{(p-1)}^* - \frac{1}{12} y_{(p-2)}^* \right] + v_p \left[\frac{m}{m+1} y_{(p+1)}^* + \frac{1}{12m} \frac{y_p^{*2}}{y_{(p+1)}^*} + \frac{7}{12} y_p^* - \frac{1}{12} y_{(p-1)}^* \right]$$

NOTE When $p = 5$, the summation term of Equation (B) is evaluated only for $i = 3$.

In Equation (B), U represents

a) either the mean velocity along a measuring line, and in this case,

v_1, v_2, \dots, v_p are the velocities measured at points located at distances l_1, l_2, \dots, l_p from the reference wall;

$$y_1^* = \frac{l_1}{L}$$

$$y_2^* = \frac{l_2 - l_1}{L}$$

⋮

$$y_p^* = \frac{l_p - l_{(p-1)}}{L}$$

$$y_{(p+1)}^* = \frac{L - l_p}{L}$$

where L is the distance between the two walls on the considered line;

b) or the mean axial fluid velocity in the measuring cross-section, and in this case,

v_1, v_2, \dots, v_p represent the mean velocities u_1, u_2, \dots, u_p along the measuring lines located at distances h_1, h_2, \dots, h_p from the reference wall;

$$y_1^* = \frac{h_1}{H}$$

$$y_2^* = \frac{h_2 - h_1}{H}$$

⋮

$$y_p^* = \frac{h_p - h_{(p-1)}}{H}$$

$$y_{(p+1)}^* = \frac{H - h_p}{H}$$

where H is the height⁹⁾ of the measuring cross-section.

10 Determination of the mean axial fluid velocity by arithmetical methods

10.1 General

The general principle of these methods is laid down in 4.1.

For each method the measuring cross-section is divided into a small number of section elements. The measuring locations are predetermined for each section element from:

- a) an assumption of the mathematical form of the velocity distribution law in the section element concerned;
- b) a choice of the weighting coefficients.

The various curves corresponding to each section element do not necessarily constitute a continuous curve with a continuous derivative in these methods.

In the peripheral zone, a logarithmic law is assumed for the velocity distribution with respect to the distance from the wall.

In the arithmetical methods described hereafter, and in the case of circular cross-sections, the weighting coefficients are taken as equal and the section elements have areas proportional to the number of measuring points in the element concerned.

10.2 Log-linear method

By hypothesis, the mathematical form of the velocity distribution law for each element is as follows:

$$u = A \lg y + By + C$$

where

y is the distance from the wall;

A , B and C are any three constants (for the outermost annulus of the cross-section B is taken to be equal to zero).

10.2.1 Circular cross-sections

The location of the measuring points corresponds to the values of the relative radius r_{ij}/R_i or of the relative distance from the wall y_{ij}/D_i shown in Table 2.

⁹⁾ See the note to 8.3.

Table 2 — Log-linear method in a circular cross-section — Location of measuring points

Number of measuring points per radius	$\frac{r_{ij}}{R_i}$	$\frac{y_{ij}}{D_i}$	$\left(\frac{D}{d}\right)_{\min}$
3	0,358 6 ± 0,010 0	0,320 7 ± 0,005 0	23,4
	0,730 2 ± 0,010 0	0,134 9 ± 0,005 0	
	0,935 8 ± 0,003 2	0,032 1 ± 0,001 6	
5	0,277 6 ± 0,010 0	0,361 2 ± 0,005 0	39,7
	0,565 8 ± 0,010 0	0,217 1 ± 0,005 0	
	0,695 0 ± 0,010 0	0,152 5 ± 0,005 0	
	0,847 0 ± 0,007 6	0,076 5 ± 0,003 8	
	0,962 2 ± 0,001 8	0,018 9 ± 0,000 9	

The mean velocity on each radius is taken as equal to the arithmetic mean of the velocities determined at the measuring points located on the radius concerned, and the mean axial fluid velocity is equal to the arithmetic mean of the mean velocities on each radius. The mean axial fluid velocity is therefore given by the arithmetic mean of the local velocities.

10.2.2 Rectangular cross-sections

Different layouts may be developed to apply the log-linear method in a rectangular cross-section, using various numbers of measuring points. This International Standard is limited to the method using 26 points, for which the location of the measuring points is given in Table 3 and in Figure 5.

In addition to the location of the measuring points given by l/L and h/H , Table 3 gives the weighting coefficients, k , for each measured velocity. In all cases, the mean axial fluid velocity, U , is equal to the weighted mean of the measured local velocities:

$$U = \frac{\sum k_i v_i}{\sum k_i}$$

For the method using 26 points, $\sum k_i = 96$.

Table 3 — Log-linear method in a rectangular cross-section — Location of measuring points and weighting coefficients

h/H	I	II	III	IV
	k for the following values of l/L			
	0,092	0,367 5	0,632 5	0,908
0,034	2	3	3	2
0,092	2	—	—	2
0,250	5	3	3	5
0,367 5	—	6	6	—
0,500	6	—	—	6
0,632 5	—	6	6	—
0,750	5	3	3	5
0,908	2	—	—	2
0,966	2	3	3	2

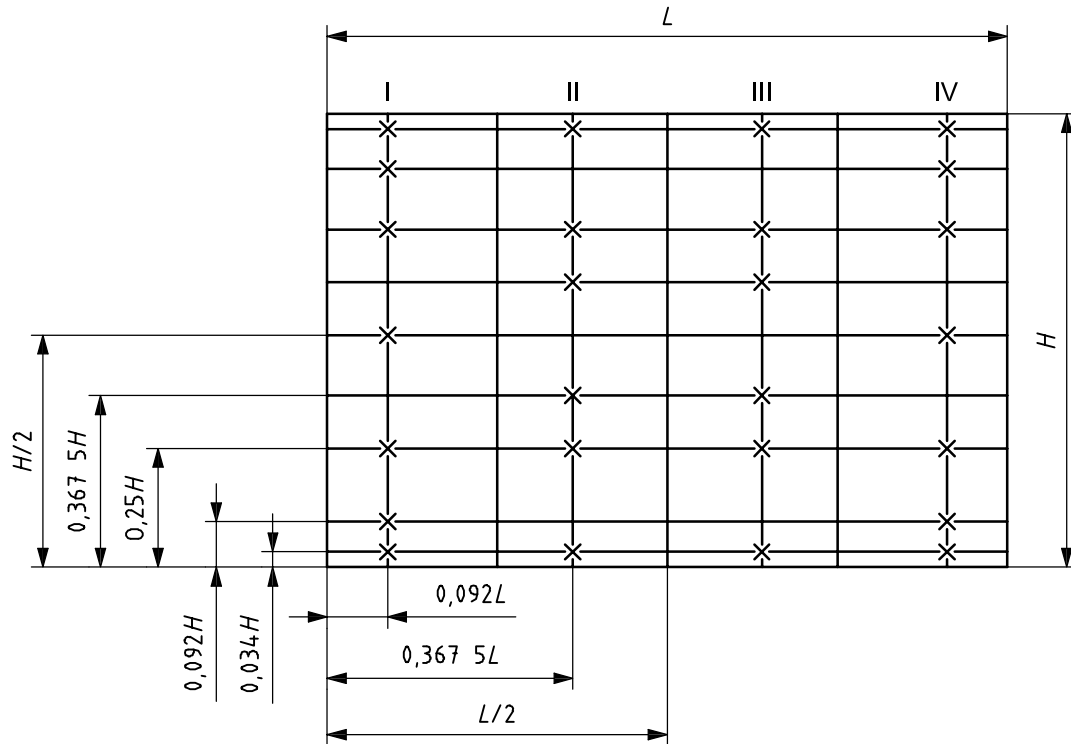

NOTE $L/d > H/d > 22$.

Figure 5 — Location of measuring points in a rectangular cross-section conduit for the log-linear method using 26 points

10.3 Log-Chebyshev method

By hypothesis, the mathematical form of the velocity distribution law as a function of the distance from the wall is logarithmic in the outermost elements of the section and polynomial in the other elements.

10.3.1 Circular cross-sections

The position of the measuring points corresponds to the values of the relative radius r_{ij}/R_i or of the relative distance to the wall y_{ij}/D_i shown in Table 4.

As the weighting coefficients have been chosen to be equal, the mean axial fluid velocity is equal to the arithmetic mean of the measured local velocities.

10.3.2 Rectangular cross-sections

A number, p' , of traverse straight lines, at least five, are selected parallel to the smaller side of the rectangle; on each line a number, p , of measuring points, at least five, are located (see Figure 6).

Table 4 — Log-Chebyshev method in a circular cross-section — Location of measuring points

Number of measuring points per radius	$\frac{r_{ij}}{R_i}$	$\frac{y_{ij}}{D_i}$	$\left(\frac{D}{d}\right)_{\min}$
3	0,375 4 ± 0,010 0	0,312 3 ± 0,005 0	23,4
	0,725 2 ± 0,010 0	0,137 4 ± 0,005 0	
	0,935 8 ± 0,003 2	0,032 1 ± 0,001 6	
4	0,331 4 ± 0,010 0	0,334 3 ± 0,005 0	32
	0,612 4 ± 0,010 0	0,193 8 ± 0,005 0	
	0,800 0 ± 0,010 0	0,100 0 ± 0,005 0	
	0,952 4 ± 0,002 4	0,023 8 ± 0,001 2	
5	0,286 6 ± 0,010 0	0,356 7 ± 0,005 0	39,7
	0,570 0 ± 0,010 0	0,215 0 ± 0,005 0	
	0,689 2 ± 0,010 0	0,155 4 ± 0,005 0	
	0,847 2 ± 0,007 6	0,076 4 ± 0,003 8	
	0,962 2 ± 0,001 8	0,018 9 ± 0,000 9	

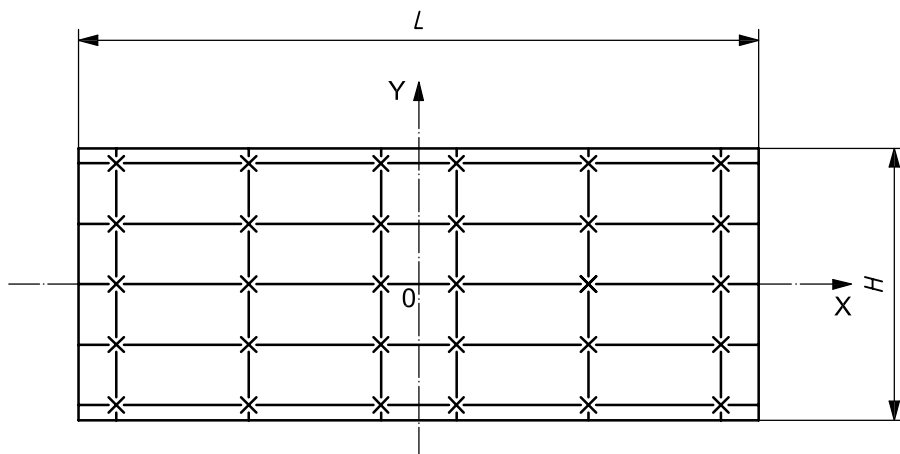

NOTE For the example chosen, $p = 5$ and $p' = 6$.

Figure 6 — Location of measuring points in a rectangular cross-section conduit in the case of the log-Chebyshev method

The positions of the pp' measuring points (abscissa X_i and ordinate Y_j in relation to the centre of the section) are defined in Table 5.

Table 5 — Log-Chebyshev method in a rectangular cross-section — Location of measuring points

p or p'	Values of $\frac{X_i}{L}$ or $\frac{Y_j}{H}$				$\left(\frac{H}{d}\right)_{\min}$
5	0	± 0,212	± 0,426		10,1
6	± 0,063	± 0,265	± 0,439		12,3
7	0	± 0,134	± 0,297	± 0,447	14,2

As the weighting coefficients have been chosen to be equal, the mean axial fluid velocity is equal to the arithmetic mean of the measured local velocities at the various measuring points.

11 Uncertainty in the measurement of flow-rate

11.1 General

The calculation of the uncertainty in the measurement of flow-rate shall be carried out in accordance with ISO 5168, but for convenience the main procedures which apply to the measurement of flow-rate by the velocity-area method using current-meters are given here. The more important terms used are defined and explained in Annex F.

In Annex H, some typical values of the uncertainty introduced by several of the sources of error are given. Note that the magnitude of these uncertainties can vary appreciably and that there are other sources of error for which it is not possible to quote typical values of the resulting uncertainties; each individual case shall therefore be the subject of careful study, but the more important sources of error are described in 11.2 and 11.3.

11.2 Sources of error in local velocity measurements

11.2.1 Random errors

11.2.1.1 Measurement of rotational frequency

The measurement of the rotational frequency of a current-meter is invariably subject to a random error owing to the counting of pulses and the measurement of time periods. The error is reduced as the time over which the measurements is made is increased.

11.2.1.2 Slow oscillations in the flow velocity

A random error will be introduced if the time of measurement is not long enough to allow correct integration of slow oscillations in the flow velocity. The error is reduced as the number and duration of measurements at a given point are increased.

11.2.2 Systematic errors

11.2.2.1 Current-meter calibration

Even though each current-meter is calibrated, there is a residual error associated with the calibration which introduces a systematic error into the velocity measurement.

11.2.2.2 Turbulence and velocity fluctuations

The finite response time of current-meters to changes in velocity results in an erroneous reading when high frequency velocity fluctuations or turbulence are present. This occurs because current-meters are calibrated by towing through still water but they are used in flowing turbulent water. The resulting error in the measured velocity will be the same for all measurements at the same point and velocity, although the errors will change with both flow-rate and position of measurement.

11.2.2.3 Velocity gradient

When a current-meter is located in an area where there is a steep transverse velocity gradient, each point of the propeller is subject, during each revolution, to quick velocity variations which result in a systematic error of the same kind as that in 11.2.2.2. This error, which can be generally neglected outside the vicinity of the walls, is reduced as the ratio, d/D , of the propeller diameter to the pipe diameter is decreased.

11.2.2.4 Current-meter alignment

If a current-meter is installed with its axis at an angle to the flow direction a systematic error will result, since the calibration results for that meter will no longer hold exactly (see, however, the note in 6.1.5).

11.2.2.5 Conduit blockage

The blockage effect is described in detail in 6.4.3 and Annex B, where the corresponding corrections are also given. However, the corrections themselves have an associated uncertainty, so that a systematic error will result when they are applied.

11.3 Sources of error in estimation of flow-rate

11.3.1 Random errors

11.3.1.1 Local velocity measurements

The errors in the local velocity measurements will not be truly random, as they will in part depend on the position of the point of measurement in the conduit. However, the error in each measurement will be different, and the major contributions to each error will be random in nature, so that the overall error contributed to the estimation of flow-rate by the uncertainty in the local velocity measurements may be regarded as random.

11.3.1.2 Graph in graphical integration technique

When the graphical integration technique is used, an error will be introduced in drawing the velocity profile and evaluating the area under the central portion of the graph, the magnitude of this error will depend both on the operator and on the shape of the velocity distribution and will be considered as random in nature.

11.3.1.3 Evaluation of boundary layer coefficient, m

If the boundary layer coefficient, m , is calculated by the graphical method given in Annex E, then the error from this source will be random in nature.

11.3.1.4 Positioning of current-meters

If the errors associated with the positioning of the current-meters are independent of one another (i.e. no large common systematic error is present, see 4.4.1), then the overall effect will be to introduce a random error into the flow-rate estimation; provided that the conditions of 4.4.1 are met, this error is negligible. However, this error becomes systematic when several measurements are made in the same cross-section without modifying the current-meter locations.

11.3.2 Systematic errors

11.3.2.1 Measurement of the dimensions of the conduit

Although the area, A , of the cross-section of flow-rate measurement is evaluated from the mean of several measurements of the conduit dimensions (see 4.2), a systematic error still remains in the calculated flow-rate.

11.3.2.2 Numerical or arithmetic integration techniques

The techniques given in Clauses 9 and 10 involve either an approximation to the velocity distribution or the assumption of a velocity distribution. For a given velocity distribution, there is therefore a systematic error introduced in the calculated flow-rate.

11.3.2.3 Number of measuring points

If the velocity distribution curve is not perfectly smooth, the number of measuring points may not be sufficient to define it adequately, and a systematic error will result.

11.4 Propagation of errors

If the various independent variables, the knowledge of which allows computation of the flow-rate, q , are X_1, X_2, \dots, X_k , then q may be expressed as a certain function of these variables:

$$q = f(X_1, X_2, \dots, X_k) \quad (1)$$

If the uncertainties associated with the variables X_1, X_2, \dots, X_k are e_1, e_2, \dots, e_k , then the uncertainty e_q in the flow-rate is defined as

$$e_q = \pm \left[\left(\frac{\partial q}{\partial X_1} e_1 \right)^2 + \left(\frac{\partial q}{\partial X_2} e_2 \right)^2 + \dots + \left(\frac{\partial q}{\partial X_k} e_k \right)^2 \right]^{1/2} \quad (2)$$

where $\partial q / \partial X_1, \partial q / \partial X_2, \dots, \partial q / \partial X_k$ are partial derivatives (see ISO 5168).

The percentage uncertainty, E_q , is given by

$$E_q = \pm 100 \frac{e_q}{q}$$

11.5 Presentation of results

Equation (2) should preferably be used to evaluate separately the uncertainties due to the random (at the 95 % confidence level) and systematic components of error. If the contributions to the uncertainty in the flow-rate measurement from these two types of error are denoted as e_r and e_s , respectively, when expressed in absolute terms, and as E_r and E_s when expressed as a percentage, the flow-rate measurement shall then be presented in one of the following forms.

a) Flow-rate, q

$$e_r = \pm (\delta q)_1 \quad e_s = \pm (\delta q)_2$$

The uncertainties are calculated in accordance with ISO 5168.

b) Flow-rate, q

$$E_r = \pm 100 (\delta q)_1 / q \quad E_s = \pm 100 (\delta q)_2 / q$$

The uncertainties are calculated in accordance with ISO 5168.

An alternative, although less satisfactory, method is to combine the uncertainties arising from random and systematic errors by the root-sum-square method. Even then, however, it is necessary to evaluate Equation (2) for the random components since the value of e_r or E_r is required. In this case, the flow-rate measurement shall be presented in one of the following forms.

c) Flow-rate, $q + \delta q$

$$e_r = \pm (\delta q)_1$$

The uncertainties are calculated in accordance with ISO 5168.

d) Flow-rate, $q \pm 100 \delta q/q$

$$E_r = \pm 100(\delta q)_1/q$$

The uncertainties are calculated in accordance with ISO 5168.

11.6 Calculation of uncertainty

Although systematic errors have been distinguished from random errors, the probability distribution of the possible values of each systematic component is essentially gaussian and, in accordance with ISO 5168, the combination of all the uncertainties may therefore be carried out by the root-sum-square method described in 11.4. It is necessary, however, to evaluate the random and systematic contributions to the uncertainty separately to express the result of the measurement according to 11.5.

11.6.1 Uncertainty in measurement of local velocities

The uncertainty associated with a measurement of local velocity, v , is obtained by combining the uncertainties arising from the sources of error described in 11.2.

The random uncertainty, $(e_r)_v$, is given by

$$(e_r)_v = \pm \left[a^2 (e_r)_n^2 + (e_r)_f^2 \right]^{1/2} \quad (3)$$

where

$(e_r)_n$ is the uncertainty in the measurement of the rotational frequency, n , of the current-meter;

$(e_r)_f$ is the uncertainty in v arising from slow oscillations in the flow velocity;

a is the coefficient of n in the calibration equation of the current-meter (see 6.3.1).

The systematic uncertainty, $(e_s)_v$, is given by

$$(e_s)_v = \pm \left[(e_s)_c^2 + (e_s)_t^2 + (e_s)_g^2 + (e_s)_\phi^2 + (e_s)_b^2 \right]^{1/2} \quad (4)$$

where

$(e_s)_c$ is the uncertainty in v arising from the use of the calibration relationship of the current-meter;

$(e_s)_t$ is the uncertainty in v due to turbulence;

$(e_s)_g$ is the uncertainty in v due to the current-meter behaviour in a velocity gradient;

$(e_s)_\phi$ is the uncertainty in v arising from possible misalignment of the current-meter;

$(e_s)_b$ is the uncertainty in v arising from the blockage correction.

The uncertainty, e_v , in a local velocity measurement is then given by

$$e_v = \pm \left[(e_r)_v^2 + (e_s)_v^2 \right]^{1/2} \quad (5)$$

11.6.2 Uncertainty in mean axial fluid velocity

When a numerical or arithmetic method is used to calculate the mean axial fluid velocity, U , from the local velocities, v_i , the generalized formula is

$$U = C_0 v_0 + C_1 v_1 + C_2 v_2 + \dots + C_p v_p \quad (6)$$

where C_0, C_1, \dots, C_p are constants.

The uncertainty in U is then given by

$$e_U = \pm \left(C_0^2 e_{v0}^2 + C_1^2 e_{v1}^2 + C_2^2 e_{v2}^2 + \dots + C_p^2 e_{vp}^2 \right)^{1/2} \quad (7)$$

NOTE For the case where arithmetic methods are applied to a circular cross-section, $C_0 = 0$ and $C_1 = C_2 = \dots = C_p = 1/p$.

Equation (7) should in principle be used to evaluate the random and systematic components separately, but as noted in 11.3.1.1, e_U will in practice be random in nature. The values for e_{v0}, e_{v1} , etc. may therefore be obtained from Equation (5), and Equation (7) need be evaluated only once; e_U can then be considered to introduce only a random contribution to the uncertainty in the flow-rate.

When the graphical integration method is used, e_U can be evaluated using Equation (7) by making

$$C_0 = C_1 = \dots = C_{p-1} = 1$$

but with

$$C_p = \frac{m}{m+1} \left(1 - \frac{r_p^2}{R^2} \right)$$

for circular cross-sections [see 8.2d)] or by taking for C_p the values of the coefficients of v_a and u_a given in 8.3c) and 8.3f) respectively for the appropriate stages in the integration across rectangular cross-sections.

In reality, the uncertainty in the value of the mean axial fluid velocity also contains contributions from other aspects of the integration technique used (see 11.3.1.2, 11.3.1.3 and 11.3.2.2), but these are listed separately in the formula for the uncertainty in the flow-rate.

11.6.3 Uncertainty in flow-rate measurement

The flow-rate, q , is given by

$$q = AU$$

where

A is the cross-sectional area of the conduit;

U is the mean axial fluid velocity.

Thus, in accordance with Equation (2), the contributions to the uncertainty in q arising from the uncertainties in A and in U are given by Ue_A and Ae_U respectively.

The uncertainty in the flow-rate measurement is obtained by combining the uncertainties arising from the sources of error described in 11.3.

The random uncertainty, $(e_r)_q$, is given by

$$(e_r)_q = \pm \left[A^2 (e_r)_U^2 + (e_r)_i^2 + (e_r)_m^2 + (e_r)_l^2 \right]^{1/2} \quad (8)$$

where

$(e_r)_U$ is obtained from Equation (7);

$(e_r)_i$ is the uncertainty in q arising from the use of the graphical integration technique;

$(e_r)_m$ is the uncertainty in q arising from the estimation of the value of m ;

$(e_r)_l$ is the uncertainty in q arising from the current-meter positioning.

The systematic uncertainty $(e_s)_q$ is given by

$$(e_s)_q = \pm \left[U^2 (e_s)_A^2 + (e_s)_i^2 + (e_s)_p^2 \right]^{1/2} \quad (9)$$

where

$(e_s)_A$ is the uncertainty in q arising from the measurement of the cross-sectional area of the conduit¹⁰⁾;

$(e_s)_i$ is the uncertainty in q arising from the use of the numerical or arithmetic integration method;

$(e_s)_p$ is the uncertainty in q arising from the number of velocity measuring points.

Annex J gives an example of the calculation of the uncertainty in the flow-rate measured by means of current-meters.

10) The relative uncertainty in the area is twice the relative uncertainty in the measurement of lengths from which it is calculated.

Annex A (normative)

Measuring sections other than circular or rectangular sections

A.1 General

When the flow-rate is to be measured using the velocity-area method in a cross-section of shape other than circular or rectangular, an arithmetic method of integration founded on the log-Chebyshev rule may be applied.

This annex deals only with the practical instructions allowing the application of the method in the types of cross-sections which are the most often used in hydraulic circuits, i.e. annular sections, rectangular sections with the corners cut off and rectangular sections with rounded corners.

The accuracy of the method will be satisfactory only as far as the conditions given in 6.1.2 are fulfilled and the flow is fully developed: in particular, the velocity profile shall never show a maximum within the peripheral areas.

The numerical specifications given in this annex for the location of current-meters comply with the general rules given in 4.4.1 and 6.4.4.

A.2 Annular sections

A.2.1 Number and location of measuring points

Measurements shall be taken at not less than four points on each of at least six equally spaced radii. It is recommended that the number of radii be increased when it is feared that the flow pattern is not axisymmetrical, and more particularly for high values of the ratio, D_0/D (where D is the mean diameter of the conduit and D_0 is the mean diameter of the core); also it is recommended that the number of points per radius be increased for low values of D_0/D .

The location of measuring points along each radius shall be in accordance with the log-Chebyshev rule. Table A.1, where y is the distance of the measuring point from the conduit wall (see Figure A.1), shows these locations in the case where four points per radius are used¹¹⁾. Where D_0/D lies between two values given in the table, then values of y/D may be obtained by linear interpolation in terms of $(D_0/D)^2$.

NOTE In conduits of diameter less than about 4 m or 5 m, and more particularly for high values of D_0/D , measurements can be carried out only by using small current-meters or microcurrent-meters.

A.2.2 Measurement of the measuring cross-section

The cross-sectional area of the annulus is $A = \pi(D^2 - D_0^2)/4$.

In reality, it may be impractical to measure D , in which case the cross-sectional area can be calculated as $A = \pi h(D_0 + h)$, where $h = (D - D_0)/2$ is the annulus height.

This annulus height is taken as equal to the arithmetic mean of measurements carried out on at least six radii at approximately equal angles to one another in the measuring section. If the difference between the lengths of any two measured heights is greater than 1 %, the number of measured heights shall be doubled.

¹¹⁾ Alternatively, it is possible to follow a log-linear rule adapted for the case of annular cross-sections. The locations so obtained would be very close to those given in Table A.1.

The value of D_0 is most conveniently determined by measuring the circumference of the core and dividing by π .

Table A.1 — Location of measuring points in an annular section for four points per radius

$\left(\frac{D_0}{D}\right)^2$	$\frac{y_1}{D}$	$\frac{y_2}{D}$	$\frac{y_3}{D}$	$\frac{y_4}{D}$	$\left(\frac{D}{d}\right)_{\min}$
0,1	0,021 32	0,087 72	0,175 93	0,288 00	35,2
0,2	0,018 89	0,077 07	0,151 96	0,239 27	39,7
0,3	0,016 47	0,066 69	0,129 54	0,198 59	45,5
0,4	0,014 07	0,056 55	0,108 40	0,162 88	53,3
0,5	0,011 69	0,046 63	0,088 35	0,130 66	64,2
0,6	0,009 32	0,036 93	0,069 23	0,101 07	80,5
0,7	0,006 97	0,027 43	0,050 92	0,073 54	108
0,8	0,004 63	0,018 11	0,033 33	0,047 69	162
0,9	0,002 31	0,008 97	0,016 38	0,023 25	325

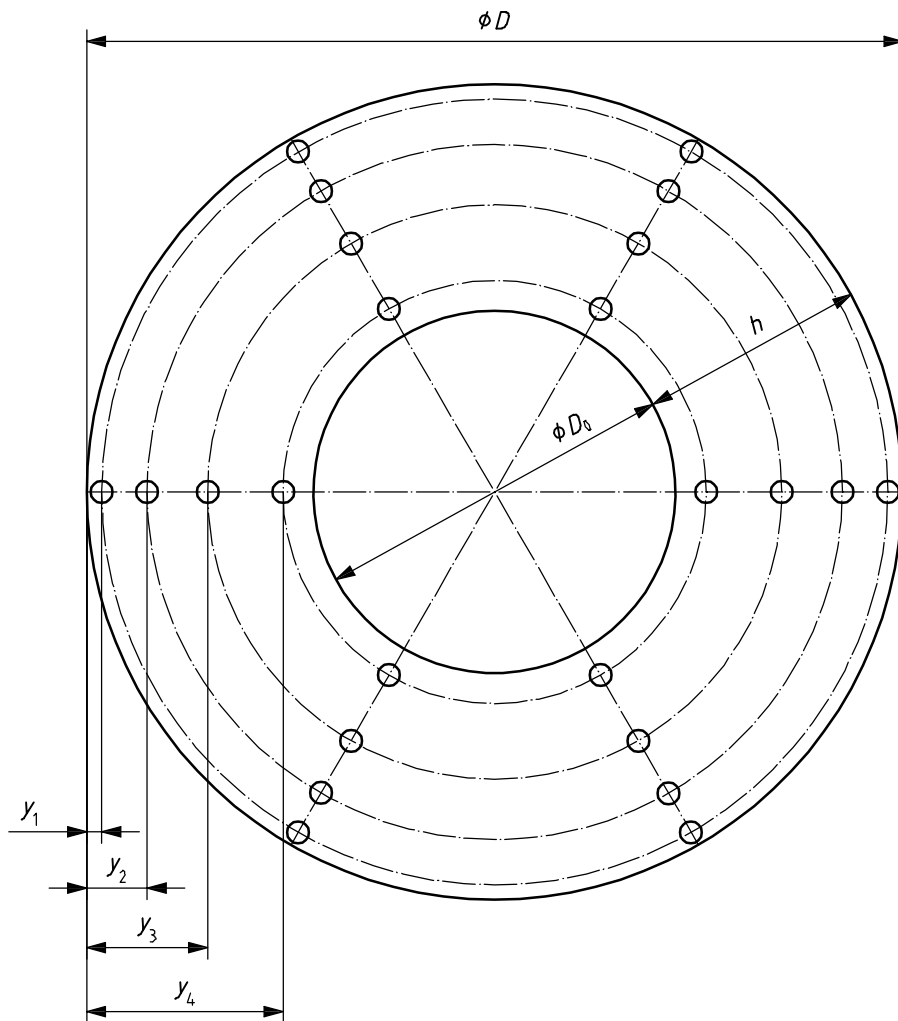

Figure A.1 — Annular section

A.2.3 Calculation of the flow-rate

The mean axial fluid velocity, U , shall be calculated as the arithmetic mean of the velocities obtained at each measuring point.

The volume flow-rate shall be determined as the product of the mean axial fluid velocity and the cross-sectional area of the annulus, i.e. $q_V = AU$.

A.3 Rectangular sections with corners cut off or rounded

A.3.1 General rules

In such sections, the log-Chebyshev method for calculating the flow-rate in rectangular sections may be applied subject to the following modifications.

- a) The measuring points shall be located along a set of at least six traverse lines perpendicular to the larger side (the base of length L) of the rectangle. The distribution of these traverse lines along the base is that according to the log-Chebyshev rule for rectangles (see 10.3.2), except for the two extreme traverse lines, the location of which is modified depending on the shape of the neighbouring walls (see A.3.2).
- b) Along each traverse line, the measuring points shall be distributed according to the log-Chebyshev rule for rectangles (see 10.3.2, Table 5 and Figure 6), with a number of points not less than six. If some extreme points are too close to the wall, taking account of the requirements specified in 4.4.1, the number of measuring points along the considered traverse lines may be reduced to five, but the total number of measuring points in the cross-section shall in any case be not less than 35.
- c) The flow-rate through the section is calculated in two steps.
 - 1) The mean velocity, u_i , along each of the p' traverse lines is derived as the arithmetic mean of the velocities v_1, v_1, \dots, v_p at each of the p measuring points of the traverse line:

$$u_i = \frac{1}{p} \sum_{j=1}^p v_j$$

- 2) Then the volume flow-rate q_V is calculated by multiplying the base length L by the arithmetic mean of the elemental flow-rates obtained by multiplying each of the mean velocities, u_i , by the length, H_i , of the corresponding traverse line:

$$q_V = \frac{L}{p'} \sum_{i=1}^{p'} u_i H_i$$

A.3.2 Locations of the traverse lines in a rectangular section with cut-off corners and in a rectangular section with quarter-circle corners

The locations of the traverse lines referred to the axis of symmetry of the section, for a number of traverses $p' = 6$ or 7 , are defined in Table A.2 in the case of rectangular sections with cut-off corners and in Table A.3 for rectangular sections with quarter-circle corners, for particular values of the parameters defining the shape of the section (see Figures A.2 and A.3).

The locations of the extreme traverse lines as given in Tables A.2 and A.3 have been calculated on the basis of a boundary layer coefficient, $m = 7$, but they vary only slightly as a function of m .

The locations of the measuring points along these traverse lines are given in 10.3.2, Table 5.

Table A.2 — Locations of the traverse lines in a rectangular section with cut-off corners

p'	x_1/L				x_2/L	x_3/L	x_4/L
	for L/H equal to						
	1	1	2	2			
for r/H equal to							
	1/3	1/4	1/3	1/4			
6	$\pm 0,419$	$\pm 0,420$	$\pm 0,417$	$\pm 0,422$	$\pm 0,265$	$\pm 0,063$	—
7	$\pm 0,431$	$\pm 0,432$	$\pm 0,429$	$\pm 0,431$	$\pm 0,297$	$\pm 0,134$	0

Table A.3 — Locations of the traverse lines in a rectangular section with quarter-circle corners

p'	x_1/L						x_2/L	x_3/L	x_4/L
	for L/H equal to								
	1	1	2	2	3/2	3			
for r/H equal to									
	1/3	1/4	1/3	1/4	1/2	1/2			
6	$\pm 0,427$	$\pm 0,430$	$\pm 0,432$	$\pm 0,436$	$\pm 0,430$	$\pm 0,440$	$\pm 0,265$	$\pm 0,063$	—
7	$\pm 0,438$	$\pm 0,439$	$\pm 0,440$	$\pm 0,443$	$\pm 0,441$	$\pm 0,451$	$\pm 0,297$	$\pm 0,134$	0

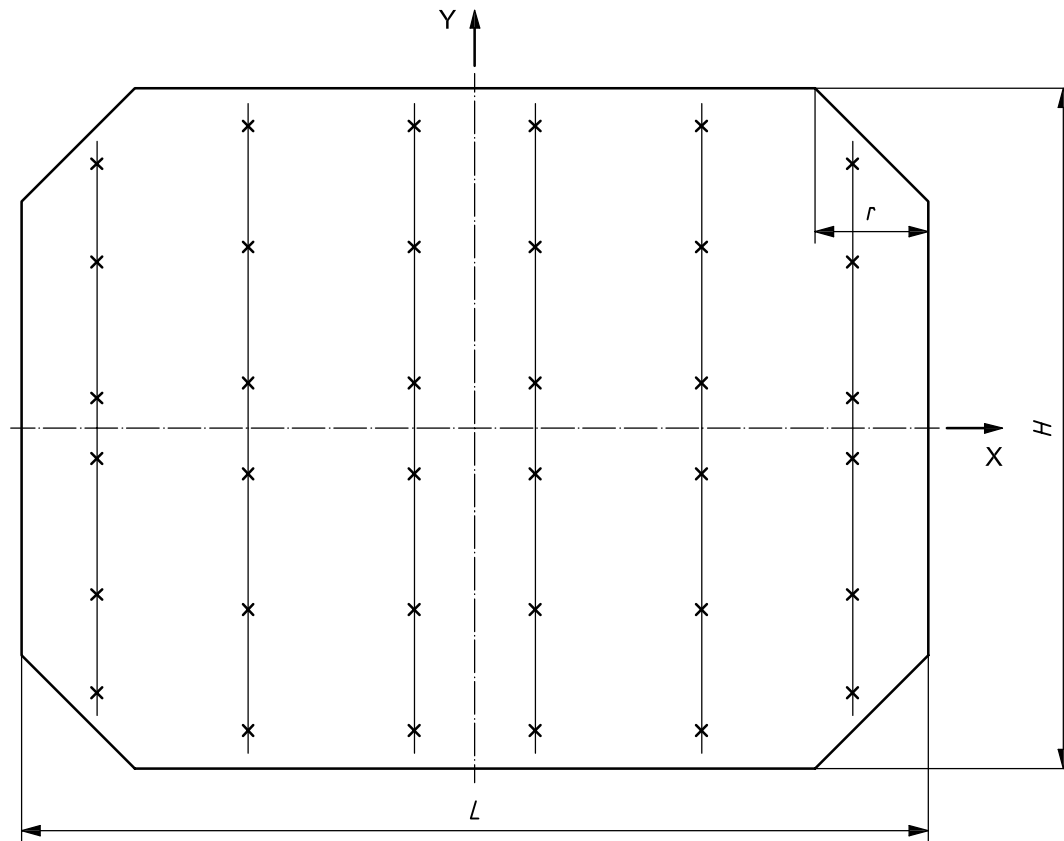

Figure A.2 — Rectangular section with cut-off corners

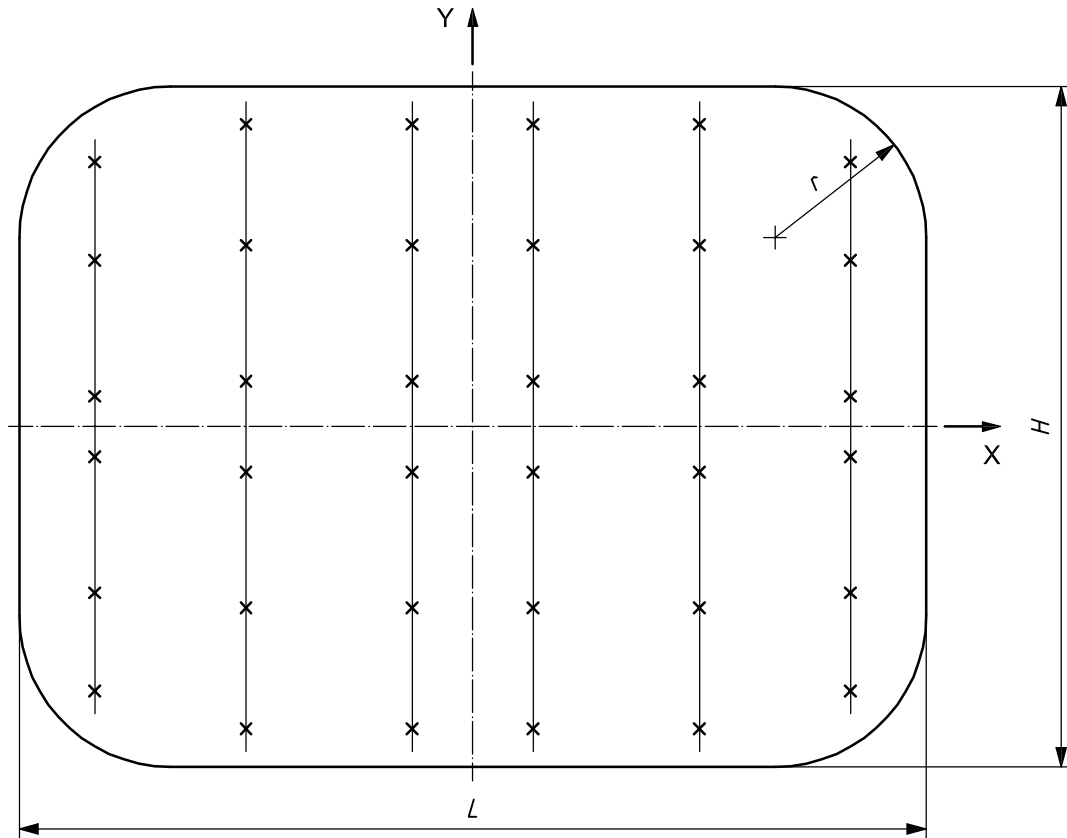

Figure A.3 — Rectangular section with quarter-circle corners

http://www.iso.org/iso/home/standards/standards_browse.htm

Annex B (normative)

Corrections for blockage effect

As outlined in 6.4.3 the presence of current-meters and their supports in a conduit results in a reduction in the cross-sectional area of flow, and hence in a variation in the velocity distribution, particularly in the measuring plane. The phenomenon is entirely different when current-meters are calibrated in a channel with a free surface and where the current-meters to be calibrated can be located at a sufficient distance from the walls. The calculation of the flow-rate in a conduit on the basis of calibration data obtained in a channel thus generally leads to an overestimation of the flow-rate.

It is very difficult to measure or calculate theoretically the magnitude of this error. In the past 20 years a number of major investigations into the problem have been made and from these certain conclusions have been drawn. These conclusions are not definitive since each combination of a number of current-meters and their support cross is likely to result in a different redistribution of the velocity profile. It appears adequate, on the basis of the present state of knowledge, to regard the error as directly proportional to the velocity over the range of velocities normally experienced. Thus, a direct percentage error correction can be used.

As stated in 6.4.3, the investigations have shown that the main parameter influencing the magnitude of the error is the ratio of the frontal area of the support cross to the cross-sectional area of the conduit. The number of current-meters being used, their type, and the size of their propellers and hubs also have an effect but this is unlikely to exceed 0,3 % with the types of current-meter normally in use and in conformity with this International Standard.

A more important factor is the distance between the plane of the propellers and the plane of the support cross. As this is increased, the influence of the blockage caused by the cross on the current-meter readings is reduced, but the risk of vibration is increased. Suggestions for the selection of the current-meter and support cross types and fixing means are given in Annex C.

On the basis of present knowledge, the following specifications shall apply.

- a) If the blockage ratio, s , i.e. the ratio between the frontal area of the mounting struts and the area of the measuring section, is less than 0,06, then the measured flow-rate will be reduced by a factor, k :

$$k = 0,12s + 0,03s_c$$

where s_c is the blockage ratio of the current-meters given by

$$s_c = \frac{\pi Z d^2}{4A}$$

where

- Z is the number of current-metres;
- d is the propeller diameter, in metres;
- A is the area, in square metres, of the measuring section.

Nevertheless, if s is less than 0,02, this correction may generally be neglected.

- b) If the blockage ratio s of the mounting struts exceeds 0,06, the measurement cannot be made in accordance with this International Standard.

Annex C (normative)

Recommendations for the selection of the type of current-meter and mounting strut

Without prohibiting the use of those types of current-meter and mounting strut used up to the time of publication, the recommendations¹²⁾ stated below are intended to orient the choice of the user towards:

- a) a type of current-meter having the lowest possible sensitivity to the effect of flow turbulence, and especially to its longitudinal component;
- b) a type of mounting strut ensuring both minimum vibration risks and stable flow separation points, and hence minimum interference with the current-meter response.

C.1 Requirements relating to the current-meter

C.1.1 The aspect ratio, $(r_{\text{propeller}} - r_{\text{hub}})^2 / A_b$, where A_b is blade area, shall be large.

C.1.2 The propeller pitch shall be sufficiently large (but not too large, to prevent drag assuming too much importance with respect to lift).

C.1.3 The blade thickness shall be rather small (which limits the propeller diameter).

C.1.4 The propeller material shall be of low density (light metal or plastic).

C.1.5 The current-meter body shall be compact, with the connecting terminal set in the body.

C.1.6 The measuring plane (which can be assimilated as a first approximation to the plane of the downstream edge of the propeller) shall be sufficiently far from the strut.

C.2 Recommendations relating to the strut

C.2.1 In order to minimize the risk of vibrations due essentially to the resonance of the natural frequency of the strut with the frequency of vortex shedding and to stabilize the separation point of the vortices, it is recommended to choose a mounting strut having an octagonal or ovoid (streamline) profile, with a relative thickness within the range 0,3 to 0,5.

C.2.2 The connecting wires shall be firmly fixed to the strut in such a way that its profile is not altered; alternatively a groove may be provided in the strut for this purpose (see Figure C.1).

12) These recommendations are in conformity with the conclusions of the most recent research work carried out within the International Current-Meter Group; these researches have led to the choice of an octagonal strut circumscribed to an ellipse of 100 mm × 30 mm and to a mounting with a distance of 265 mm between the trailing edge of the propeller and the leading edge of the strut.

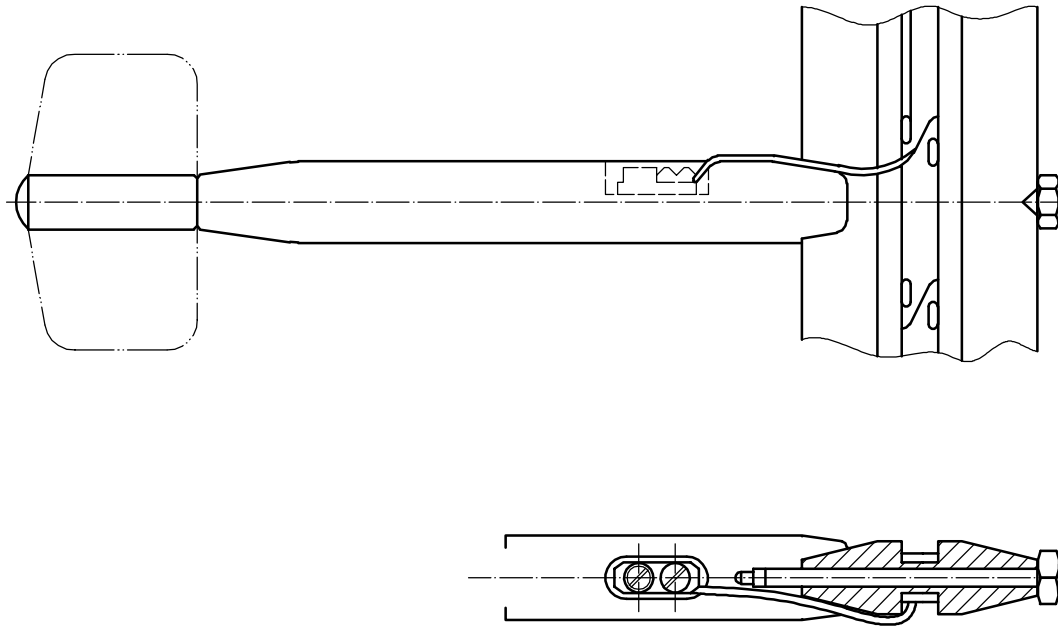

Figure C.1 — Example of mounting strut

Annex D (normative)

Example of measuring point distribution along a radius for velocity measurement in a conduit of circular cross-section in the case of the graphical and numerical methods

D.1 Location of the measuring points

When there is no information on the velocity distribution, various layouts of the measuring points along a radius may be used according to the number of measuring points used. The locations indicated as examples in Figure D.1 and in Table D.1 correspond roughly to equal flow-rate rings in the case of a uniform velocity distribution (in the hope of minimizing the influence of random errors in the determination of the local velocities by giving approximately the same weight to all current-meters).

NOTE 1 The distributions shown may need to be amended sometimes so as to meet mandatory requirements concerning the minimum distance between two current-meters (see 4.4.1).

NOTE 2 A current-meter should be placed on the pipe axis.

The measuring points are distributed according to the following law:

$$\frac{r_i}{r_p} = \sqrt{\frac{i}{p}}$$

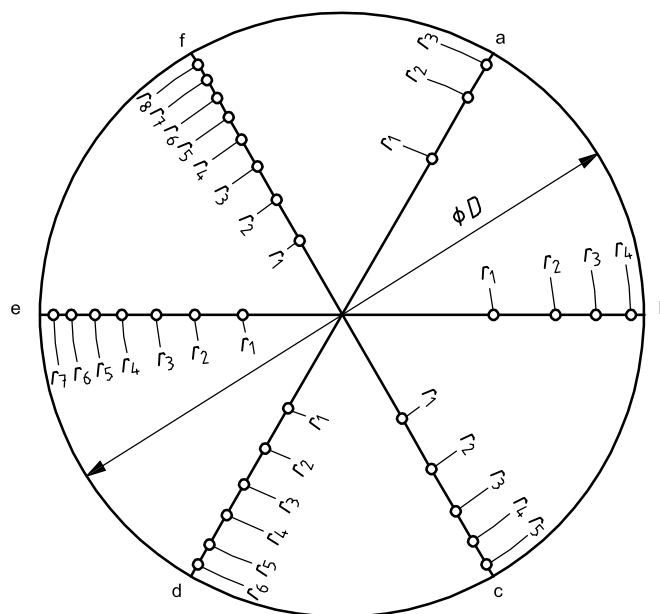

Key

- | | | | |
|---|----------------------|---|----------------------|
| a | 3 points per radius. | d | 6 points per radius. |
| b | 4 points per radius. | e | 7 points per radius. |
| c | 5 points per radius. | f | 8 points per radius. |

Figure D.1 — Example of measuring point distribution in a conduit of circular cross-section

D.2 Calculation of the mean axial fluid velocity by the numerical method

The expression for the mean axial fluid velocity given in 9.2 can be written as follows:

$$U = r_p^{*2} \sum_{i=0}^p \alpha_i u_i + \beta u_p$$

where

$$\beta = \frac{m}{m+1} \left(1 - r_p^{*2}\right) + \frac{\left[\frac{r_p^{*2} - r_{(p-1)}^{*2}}{(p-1)} \right]^2}{12m \left(1 - r_p^{*2}\right)}$$

and where the coefficients α_i are independent of R and depend only on the ratios, r_i/r_p .

As an example, if the distribution of measuring points as defined in Table D.1 is used, Table D.2 gives the values of coefficients, α_i , when p varies from 3 to 8.

Table D.1 — Measuring point distribution

p	r_p	$\frac{r_{(p-1)}}{r_p}$	$\frac{r_{(p-2)}}{r_p}$	$\frac{r_{(p-3)}}{r_p}$	$\frac{r_{(p-4)}}{r_p}$	$\frac{r_{(p-5)}}{r_p}$	$\frac{r_{(p-6)}}{r_p}$	$\frac{r_{(p-7)}}{r_p}$	D^a mm
3	$\frac{D}{2} - 0,75d$	0,816	0,577	—	—	—	—	—	1 200 to 2 400
4	$\frac{D}{2} - 0,75d$	0,866	0,707	0,500	—	—	—	—	2 200 to 3 200
5	$\frac{D}{2} - 0,75d$	0,894	0,775	0,632	0,447	—	—	—	2 900 to 4 500
6	$\frac{D}{2} - 0,75d$	0,912	0,816	0,707	0,577	0,408	—	—	3 800 to 5 500
7	$\frac{D}{2} - 0,75d$	0,926	0,845	0,756	0,655	0,535	0,378	—	5 000 to 7 000
8	$\frac{D}{2} - 0,75d$	0,936	0,866	0,791	0,707	0,613	0,500	0,354	6 300 to 8 500

^a These values are given for information only.

Table D.2 — Values of coefficients, α_i , for a number, p , of measuring points

p	α_0	α_1	α_2	α_3	α_4	α_5	α_6	α_7	α_8
3	0,102 98	0,416 67	0,313 69	0,166 67	—	—	—	—	—
4	0,077 23	0,312 50	0,235 27	0,250 00	0,125 00	—	—	—	—
5	0,061 79	0,250 00	0,188 21	0,200 00	0,200 00	0,100 00	—	—	—
6	0,051 49	0,208 33	0,156 85	0,166 67	0,166 67	0,166 67	0,083 33	—	—
7	0,044 13	0,178 57	0,134 44	0,142 86	0,142 86	0,142 86	0,142 86	0,071 43	—
8	0,038 62	0,156 25	0,117 63	0,125 00	0,125 00	0,125 00	0,125 00	0,125 00	0,062 50

Annex E (normative)

Determination of boundary layer coefficient, m , for extrapolation near the wall

E.1 Graphical determination

To calculate the mean axial fluid velocity in the peripheral zone, the coefficient, m , can be determined graphically from the measured velocities.

If the curve of the measured local velocities against the distance from the wall is plotted in logarithmic coordinates (see Figure E.1 for the case of a circular cross-section), Karman's law (see 8.2) shows that in the peripheral zone this curve is a straight line, the slope of which is equal to $1/m$.

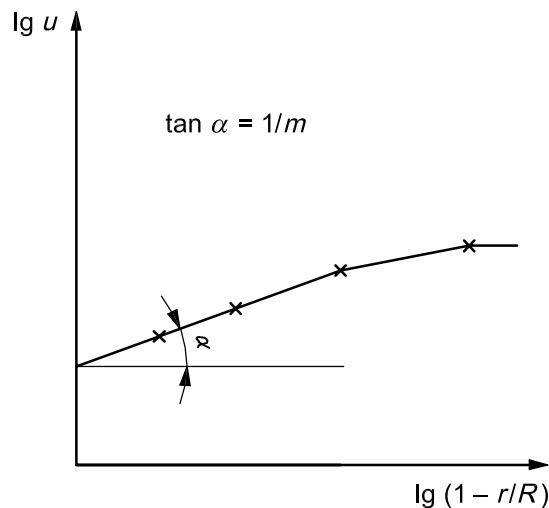

Figure E.1 — Velocity distribution in the peripheral zone

E.2 Usual values

The value of m is dependent essentially on the surface roughness of the conduit (see 8.2); it also depends on the flow conditions (Reynolds number, velocity distribution, etc.).

In almost all practical cases, m lies within the range from 4 to 14, and is very often close to 8.

As a guide, calculations taking as a basis the theoretical laws for velocity distribution in rough turbulent fully developed flow show that the boundary layer coefficient, m , is related to the universal coefficient for head loss, λ , as shown in Table E.1.

Table E.1 — Boundary layer coefficient, m , as a function of λ

λ	m	λ	m
0,006	13,1	0,020	6,7
0,007	12,1	0,022	6,4
0,008	11,2	0,024	6,1
0,009	10,5	0,026	5,8
0,010	10,0	0,028	5,6
0,012	9,1	0,030	5,4
0,014	8,3	0,035	5,0
0,016	7,7	0,040	4,6
0,018	7,2	0,045	4,3

The value of λ can be calculated from the equation

$$\lambda^{-1/2} = -2 \lg \left(\frac{2,51}{Re \lambda^{1/2}} + \frac{k}{3,7D} \right)$$

where k is the equivalent uniform roughness.

It should be noted that the error arising in the determination of m has only a small effect on the total error in the flow-rate measurement, reducing as the size of the measuring section is increased and when the extreme measuring points are closer to the wall. An estimation of this error may be found in Clause H.3.

Annex F (normative)

Definition of terms and procedures used in the uncertainty calculation

F.1 Definition of the error

The error in the estimate of a quantity is the difference between that estimate and the true value of the quantity.

No measurement of a physical quantity is free from uncertainties arising either from systematic errors or from the random dispersion of measurement results. Systematic errors cannot be reduced by repeating measurements since they arise from the characteristics of the measuring apparatus, the installation and the flow characteristics. However, a reduction in the random error may be achieved by repetition of measurements, since the random error of the mean of n independent measurements is \sqrt{n} times smaller than the random error of an individual measurement.

F.2 Definition of uncertainty

The range within which the true value of a measured quantity can be expected to lie with a suitably high probability is termed the uncertainty in the measurement. For the purposes of this International Standard, the probability to be used shall be the 95 % confidence level.

F.3 Definition of the standard deviation¹³⁾

If a variable, X , is measured several times, each measurement being independent of the others, then the standard deviation, s_X , of the distribution of n measurements, X_i , is

$$s_X = \left[\frac{\sum_{i=1}^n (X_i - \bar{X})^2}{n-1} \right]^{1/2}$$

where

\bar{X} is the arithmetic mean of the n measurements of the variable X ;

X_i is the value obtained by the i th measurement of the variable X ;

n is the total number of measurements of X .

For brevity, s_X is normally referred to as the standard deviation of X .

13) The standard deviation defined here is more accurately called the "estimated standard deviation" by statisticians.

F.4 Assessment of uncertainty

F.4.1 Random errors

If the true standard deviation, σ_X , is known, the range $\pm 1,96 \sigma_X$ would be expected to contain 95 % of the population, i.e. there would be a probability of 0,05 of the interval $\bar{X} \pm 1,96 \sigma_X$ not including the true value of X ; $\pm 1,96 \sigma_X$ is the uncertainty in the measurement.

In practice, of course, it is possible to obtain only an estimate of the standard deviation since an infinite number of measurements would be required in order to determine it precisely, and confidence limits are based on this estimate. The t distribution for small samples shall then be used to determine the uncertainty at the 95 % confidence level, as described in Annex G.

F.4.2 Systematic errors

The procedure to be followed to obtain the uncertainty associated with a systematic error depends on the information available on the error itself.

F.4.2.1 If the error has a unique known value then this shall be added to (or subtracted from) the result of the measurement, and the uncertainty in the measurement due to this source is then taken as zero.

F.4.2.2 When the sign of the error is known but its magnitude has to be estimated subjectively, the mean estimated error shall be added to the result of the measurement (paying due observance to sign) and the uncertainty shall be taken as one-half of the range within which the error is estimated to lie. This is illustrated in Figure F.1, where the measured value is denoted by M and the systematic error is estimated to lie between δt_1 and δt_2 [giving a mean estimated error of $(\delta t_1 + \delta t_2)/2$]. The result, R , to be used is then given by

$$R = M + \frac{\delta t_1 + \delta t_2}{2}$$

with an uncertainty of $\pm \left(\frac{\delta t_1 - \delta t_2}{2} \right)$.

Putting the mean estimated error equal to the mean of the estimated maximum and minimum values assumes implicitly that the systematic error be regarded as asymmetric.

F.4.2.3 When the magnitude of the systematic uncertainty can be assessed experimentally, the uncertainty shall be calculated as described in F.4.1 for random errors, with the measured value being adjusted as described above. Such a situation would arise where, for example, a weighing machine is calibrated and adjusted. Any given reading will have a systematic error, but individual readings will be distributed in a random manner about the true values; in applying a global uncertainty to the weighing-machine result, this random uncertainty can be used to set confidence limits about the measured value.

F.4.2.4 When the sign of the error is unknown and its magnitude is assessed subjectively, the mean estimated error is equal to zero and the uncertainty shall again be taken as one-half of the estimated range of the error. This is illustrated in Figure F.2, where the notation is as before. In this case, $|\delta t_1| = |\delta t_2|$ so that the uncertainty is $\pm \delta t$.

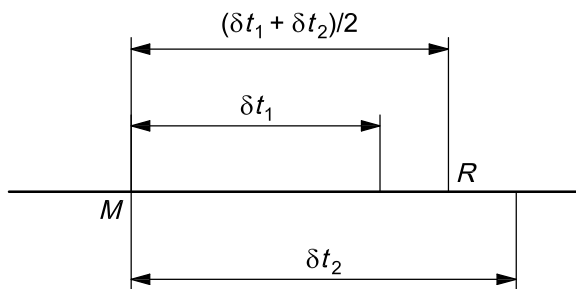

Figure F.1 — Illustration of the correction to allow for the mean estimated systematic error

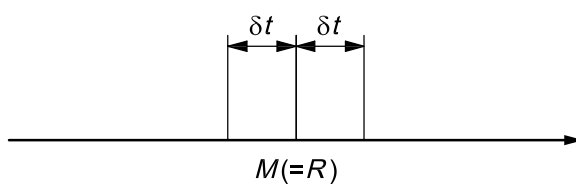

Figure F.2 — Uncertainty, $\pm \delta t$

Annex G (normative)

Student's t distribution

The uncertainty at the 95 % confidence level may be found as follows:

- a) if n is the number of measurements, $n - 1$ is taken as the number of degrees of freedom, ν_{df} ;
- b) obtain the value of t for the appropriate number of degrees of freedom, $n - 1$, from Table G.1;
- c) calculate the standard deviation, s_X , of the distribution of the measurements of the quantity X ;
- d) the range of values within which any reading would be expected to lie with 95 % confidence is $X \pm ts_X$;
- e) the range of values within which the true mean would be expected to lie with 95 % confidence is $\bar{X} \pm ts_X/\sqrt{n}$.

Table G.1 — Values of Student's t

Number of degrees of freedom $\nu_{df} = n - 1$	t (at 95 % confidence level)
1	12,706
2	4,303
3	3,182
4	2,776
5	2,571
6	2,447
7	2,365
10	2,228
15	2,131
20	2,086
30	2,042
60	2,000
∞	1,960

© ISO 2008 – All rights reserved

Annex H (informative)

Examples of values of component uncertainties

The values of the uncertainties shall be assessed by the user of this International Standard for each particular case. Values of some uncertainties are given, for guidance only, in the clauses below.

H.1 Uncertainties in local velocity measurement

H.1.1 Uncertainty due to current-meter calibration

It may be considered that for each individual current-meter the corresponding relative uncertainty may be $\pm 0,7\%$. This is valid for conventional current-meters with propellers of 0,1 m diameter and at velocities greater than 0,5 m/s.

H.1.2 Uncertainty due to turbulence and velocity fluctuations

The magnitude of these effects is not very well known but it may be assumed that the maximum errors will be $\pm 1\%$, i.e. that the relative uncertainty will be $\pm 1\%$.

H.1.3 Uncertainty due to velocity gradient

With commonly used propellers of about 0,1 m diameter, located at the minimum permissible distance from the wall, it may be assumed that the maximum error and thus the relative uncertainty will be $\pm 0,5\%$. For the same propellers located at a measuring point further from the wall, this uncertainty may be taken to be equal to zero.

H.1.4 Uncertainty due to current-meter alignment

With commonly used propellers, the error may reach a maximum value of $\pm 0,7\%$ for an inclination of 5° of the propeller axis with respect to the flow, i.e. a relative uncertainty of $\pm 0,7\%$. With self-compensating propellers, the error is negligible for inclinations less than 5° .

H.1.5 Uncertainty due to blockage effect

As stated in Annex B, the blockage effect caused by the presence of the current-meters and their support crosses is not precisely known. A large uncertainty is therefore associated with the correction indicated in Annex B. As an estimation of the relative uncertainty, a value equal to two-thirds of the correction made according to the requirements of a) of Annex B shall be taken.

This uncertainty shall be taken into account even when s is less than 0,02 and when no correction for blockage effect is necessary.

H.2 Uncertainty due to integration

The relative uncertainty may reach $\pm 0,2\%$ when the minimum permissible number of measuring points is used.

H.3 Selection of coefficient m

The error in the calculated flow-rate owing to a bad choice of m will increase as:

- a) the error in m increases;
- b) the exact value of m decreases;
- c) the relative importance of the peripheral zone increases (hence, practically, for a given apparatus, as the conduit dimensions decrease).

Thus, with current-meters used at the time of publication and for an exact value of $m = 7$, an error of 1 (unity) on m can be assumed to give a relative uncertainty of $\pm 0,04$ % for a conduit 5 m in diameter, of $\pm 0,2$ % for a conduit 3 m in diameter and of $\pm 0,4$ % for a conduit 2 m in diameter.

It should also be noted that, in case of doubt, it is preferable to overestimate m as the error in flow-rate is less when m is overestimated than when it is underestimated.

H.4 Uncertainty due to the selection of the number of points

The number of points shall be sufficient to ensure that any “hollow” or “bump” in the velocity profile is explored. Otherwise, a relative uncertainty will be introduced, which should be less than $\pm 0,4$ % if the flow conditions are to comply with this International Standard.

Annex J (informative)

Example of calculation of the uncertainty in the flow-rate measurement using current-meters

This example is based on the estimations made of the different uncertainties which arise during a flow-rate measurement carried out under normal conditions. No general significances shall be attached to the values given below since they have been used only to illustrate the method of calculation.

J.1 Uncertainty in the local velocity measurement

J.1.1 Uncertainty arising from the rotational frequency of the current-meter

The uncertainty arising from the rotational frequency of the current-meter is

$$(e_r)_n = \pm 0,005 \, n$$

J.1.2 Uncertainty arising from slow oscillations in the velocity

If the amplitude a of the oscillations is $0,01 \, v$, where v is the local velocity, then since

$$(e_r)_f = \frac{\pm 2(\sqrt{2} - 1)a}{4}$$

this uncertainty is

$$(e_r)_f = \pm 0,002 \, v$$

J.1.3 Uncertainty arising from calibration of the current-meter

The uncertainty arising from calibration of the current-meter is

$$(e_s)_c = \pm 0,007 \, v$$

J.1.4 Uncertainty arising from high-frequency fluctuations and turbulence

The uncertainty arising from high-frequency fluctuations and turbulence is

$$(e_s)_t = \pm 0,01 \, v$$

J.1.5 Uncertainty arising from the velocity gradient

The uncertainty arising from the velocity gradient is

$$(e_s)_g = \pm 0,005 \, v$$

J.1.6 Uncertainty arising from current-meter alignment

The uncertainty arising from current-meter alignment is

$$(e_s)_\varphi = \pm 0,005 v$$

J.1.7 Uncertainty in the blockage effect correction

For a relative blockage $s = 0,06$ and $s_c = 0,025$, this uncertainty is

$$(e_s)_b = \pm \frac{2}{3}(0,12s + 0,03s_c) v = \pm 0,005 3 v$$

J.1.8 Uncertainty in local velocity

Let the current-meter calibration equation be

$$v = \pm 0,239 2 n + 0,020$$

and the current-meter rotational speed at the measuring point considered be $n = 18$ r/s, giving a flow velocity, $v = 4,326$ m/s.

Thus, substituting the values listed in J.1.1 to J.1.7 into Equations (3), (4) and (5) gives e_v , in metres per second:

$$e_v = \pm \left[(0,239 2 \times 5 \times 18)^2 + (4 + 49 + 100 + 25 + 25 + 28,1) \times 4,326^2 \right]^{1/2} \times 10^{-3}$$

$$e_v = \pm 0,069$$

J.2 Uncertainty in the mean axial fluid velocity

Let us assume that the log-Chebyshev integration method was used, and so $C_0 = 0$ and $C_1 = C_2 = \dots = C_p = 1/p$ in Equation (7) of 11.6.2. By repeating the calculation procedure of Clause J.1 for each of the local velocity measurements, the mean value obtained for e_U from Equation (7) is found to be $\pm 0,066$ m/s.

J.3 Uncertainty in the flow-rate measurement

J.3.1 Uncertainty in the mean axial fluid velocity

The uncertainty in the mean axial fluid velocity, in metres per second, is obtained as specified in Clauses J.1 and J.2:

$$(e_r)_U = \pm 0,066$$

J.3.2 Uncertainty arising from the estimation of m

Since the log-Chebyshev integration technique was used, there is no contribution to the uncertainty from this source, and no random contribution from the integration technique.

J.3.3 Uncertainty arising from current-meter positioning

The uncertainty arising from current-meter positioning is

$$(e_r)_I = \pm 0,001 q$$

J.3.4 Uncertainty in the measurement of the cross-sectional area

The uncertainty in the measurement of the cross-sectional area is

$$(e_s)_A = \pm 0,004 A$$

J.3.5 Uncertainty due to the log-Chebyshev integration technique

The uncertainty due to the log-Chebyshev integration technique is

$$(e_s)_i = \pm 0,002 q$$

J.3.6 Uncertainty arising from an insufficient number of measuring points

The uncertainty arising from an insufficient number of measuring points is

$$(e_s)_p = \pm 0,002 q$$

J.3.7 Uncertainty in the flow-rate

If it is assumed that the cross-sectional area of the conduit is 3,253 m², and the mean axial fluid velocity is 4,68 m/s, a flow-rate of 15,22 m³/s is obtained.

The random uncertainty, in cubic metres per second, is thus given by Equation (8):

$$(e_r)_q = \pm \left[(3,253 \times 0,066)^2 + (0,001 \times 15,22)^2 \right]^{1/2}$$

$$(e_r)_q = \pm 0,215$$

The systematic uncertainty, in cubic metres per second, is given by Equation (9):

$$(e_s)_q = \pm \left[(4,68 \times 0,004 \times 3,253)^2 + (0,002 \times 15,22)^2 + (0,002 \times 15,22)^2 \right]^{1/2}$$

$$(e_s)_q = \pm 0,075$$

Thus the calculation of the uncertainty in the flow-rate measurement, in cubic metres per second, results in

$$q = 15,22$$

$$(e_r)_{95} = \pm 0,215$$

$$e_s = \pm 0,075$$

As an alternative, the results may be presented in one of the other forms proposed in 11.5, e.g.

$$q = (15,22 \pm 1,5 \%) \text{ m}^3/\text{s}$$

$$(E_r)_{95} = \pm 1,4 \%$$

1

ICS 17.120.10

Price based on 53 pages