

INTERNATIONAL STANDARD

ISO 3287

Second edition
1999-12-01

Powered industrial trucks — Symbols for operator controls and other displays

*Chariots de manutention automoteurs — Symboles pour les organes de
commandes de l'opérateur et autres dispositifs indicateurs*



Reference number
ISO 3287:1999(E)

Contents

1 Scope	1
2 Normative references	1
3 Term and definition	1
4 General.....	1
5 Colour	2
6 Basic symbols.....	3
7 Brake system symbols.....	6
8 Cab symbols.....	7
9 Driving controls symbols.....	10
10 Engine symbols	11
11 Electrical system symbols	14
12 Fuel symbols	15
13 Transmission symbols.....	16
14 Hydraulic system symbols.....	17
15 Lighting symbols	18
16 Maintenance symbols.....	19
17 Load-handling control symbols	21
Annex A (informative) Symbols listed by reference number	35
Annex B (informative) Symbols listed by key identifier noun.....	40
Bibliography	45

© ISO 1999

All rights reserved. Unless otherwise specified, no part of this publication may be reproduced or utilized in any form or by any means, electronic or mechanical, including photocopying and microfilm, without permission in writing from the publisher.

International Organization for Standardization
Case postale 56 • CH-1211 Genève 20 • Switzerland
Internet iso@iso.ch

Printed in Switzerland

Foreword

ISO (the International Organization for Standardization) is a worldwide federation of national standards bodies (ISO member bodies). The work of preparing International Standards is normally carried out through ISO technical committees. Each member body interested in a subject for which a technical committee has been established has the right to be represented on that committee. International organizations, governmental and non-governmental, in liaison with ISO, also take part in the work. ISO collaborates closely with the International Electrotechnical Commission (IEC) on all matters of electrotechnical standardization.

International Standards are drafted in accordance with the rules given in the ISO/IEC Directives, Part 3.

International Standard ISO 3287 was prepared by Technical Committee ISO/TC 110, *Industrial trucks*, Subcommittee SC 2, *Safety of powered industrial trucks*.

This second edition cancels and replaces the first edition (ISO 3287:1978), which has been technically revised.

Annexes A and B of this International Standard are for information only.

.....

Powered industrial trucks — Symbols for operator controls and other displays

1 Scope

This International Standard establishes symbols for use on operator controls and other displays on powered industrial trucks.

2 Normative references

The following normative documents contain provisions which, through reference in this text, constitute provisions of this International Standard. For dated references, subsequent amendments to, or revisions of, any of these publications do not apply. However, parties to agreements based on this International Standard are encouraged to investigate the possibility of applying the most recent editions of the normative documents indicated below. For undated references, the latest edition of the normative document referred to applies. Members of ISO and IEC maintain registers of currently valid International Standards.

ISO 3461-1:1988, *General principles for the creation of graphical symbols — Part 1: Graphical symbols for use on equipment*.

ISO 4196, *Graphical symbols — Use of arrows*.

3 Term and definition

For the purposes of this International Standard, the following term and definition apply.

3.1

symbol

visually perceptible figure used to transmit information independently of language

NOTE It may be produced by drawing, printing or other means.

4 General

4.1 Symbols shall be as shown in succeeding clauses of this International Standard. However, symbols which are shown in outline form may, in actual use, be filled for enhanced clarity of reproduction and improved visual perception by the operator, except as otherwise noted for individual symbols.

4.2 Limitations inherent in some reproduction and display technologies may require increased line thickness or other minor modifications of symbols. Such modifications are acceptable provided the symbol remains unchanged in its basic graphical elements and easily discernible by the operator.

4.3 Additionally, to improve the appearance and perceptibility of a graphical symbol, or to coordinate with the design of the equipment to which the symbol is applied, it may be necessary to change the line thickness or round the corners of a symbol. The graphic designer is normally free to make such changes, provided that the essential perceptual characteristics of the symbol are maintained. See ISO 3461-1:1988, subclause 10.2.

4.4 For actual use, all symbols shall be reproduced large enough to be easily discernible by the operator. See ISO 3461-1 for guidelines on the proper sizing of symbols. Symbols shall be used in the orientation shown in this International Standard unless otherwise noted for individual symbols.

4.5 Most symbols are constructed using a building block approach in which various symbols and symbol elements are combined in a logical manner to produce new symbols.

4.6 If a symbol shows a machine or parts of a machine from a side view, a machine moving from right to left across the symbol grid area shall be assumed. If a symbol shows a machine or parts of a machine from an overhead view, a machine moving from bottom to top across the symbol grid area shall be assumed.

4.7 Symbols on controls and displays shall have good contrast to their background. A light symbol on a dark background is preferred for most controls. Displays may use either a light symbol on a dark background or a dark symbol on a light background, depending upon which alternative provides the best visual perception. When a symbol image is reversed (for example, from black-on-white to white-on-black and vice versa), it shall be done for the entire symbol.

4.8 Symbols shall be located on or adjacent to the control or display that is being identified. Where more than one symbol is required for a control, the symbols shall be located in relation to the control such that movement of the control toward the symbol shall effect the function depicted by that symbol.

4.9 Arrows used in symbols shall conform to the requirements of ISO 4196. ISO 3461-1 shall be consulted for the general principles of creating symbols.

4.10 ISO/IEC registration numbers are shown for symbols in this International Standard. Registration numbers below 5000 refer to ISO 7000. Registration numbers above 5000 refer to IEC 417.

4.11 Letters and numerals may be used as symbols, but are not registered by ISO/TC 145 or published in ISO 7000. The fonts shown in this International Standard are not intended to be restrictive: other fonts may be substituted, but care shall be taken to ensure that legibility is maintained.

4.12 Symbols in this International Standard are presented within the outer limits of a 24 mm square grid (32 % of original size on the ISO graphics grid). Grid marks "L" delimit the corners of the 75 mm square graphics grid from ISO 3461-1. Corner marks are not part of the symbol, but are provided to ensure consistent presentation of all symbol graphics.

5 Colour

5.1 When used on illuminated displays, the following colours have the meanings indicated:

- **red:** failure, serious malfunction, or dangerous operating condition that requires immediate attention;
- **yellow or amber:** outside normal operating limits or approaching a dangerous operating condition;
- **green:** normal operating conditions.

5.2 In addition, certain colours are used for specific functions:





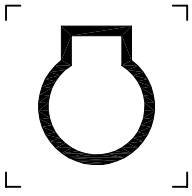
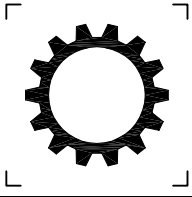
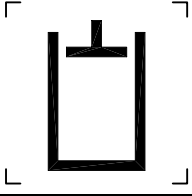
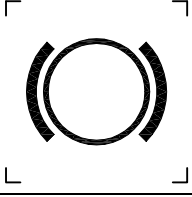
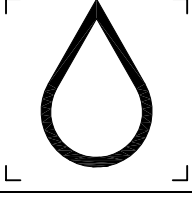
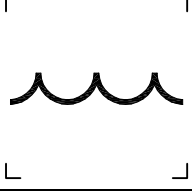
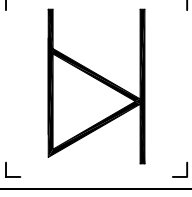
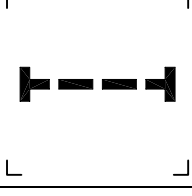

- **blue:** headlight main/high beam display;
- **red:** hazard warning display;
- **green:** turn signal display.

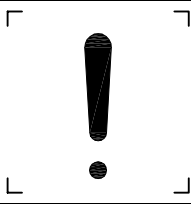
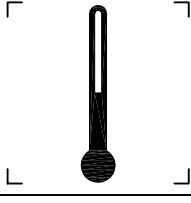
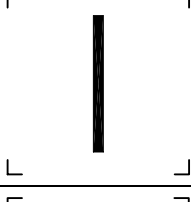
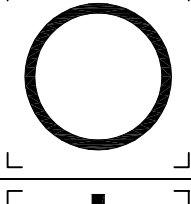
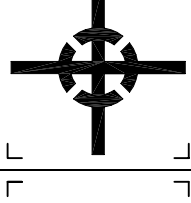
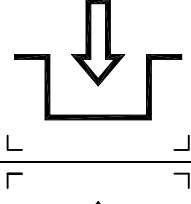
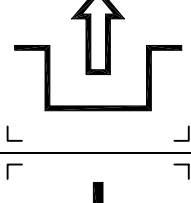
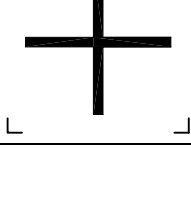

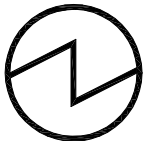
5.3 If colour is used on symbols for heating and/or cooling systems, the colour **red** shall be used to indicate hot and the colour **blue** shall be used to indicate cold.

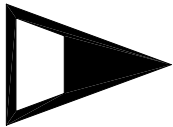
6 Basic symbols



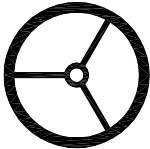

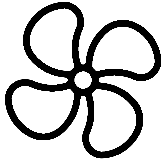
Reference number	Symbol form/shape	Symbol description/application	ISO/IEC registration number
6.1		Engine (RIC engine)	1156
6.2		Transmission	1166
6.3		Hydraulic system	1409
6.4		Brake system	1399
6.5		Oil	1056
6.6		Water	0536
6.7		Level indicator	Application of 0159
6.8		Filter	1369

Reference number	Symbol form/shape	Symbol description/application	ISO/IEC registration number
6.9		Failure/malfunction	1603
6.10		Temperature	0034
6.11		On	5007
6.12		Off	5008
6.13		Centre of gravity	0627
6.14		Engage	0022
6.15		Disengage	0023
6.16		Increase/positive polarity	5005

Reference number	Symbol form/shape	Symbol description/application	ISO/IEC registration number
6.17		Decrease/negative polarity	5006
6.18		Electric energy	0232
6.19		Fast run	5108
6.20		Slow run	5124
6.21		Fast	Application Example
6.22		Slow	Application Example
6.23		Lock	1656
6.24		Steering	0326

Reference number	Symbol form/shape	Symbol description/application	ISO/IEC registration number
6.25		Ventilating/air circulating fan	0089
6.26		Progressively variable — Rotation	1364

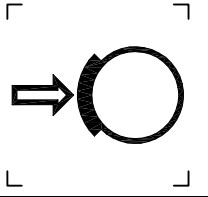
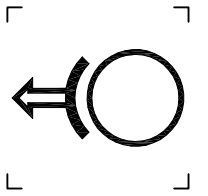

7 Brake system symbols

Reference number	Symbol form/shape	Symbol description/application	ISO/IEC registration number
7.1		Brake fluid	1400
7.2		Brake system — Pressure	1402
7.3		Brake system — Failure/malfunction	0239
7.4		Parking brake	0238
7.5		Worn brake linings	1408

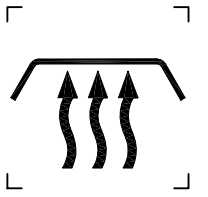
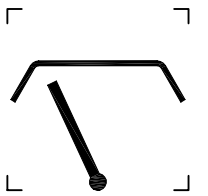
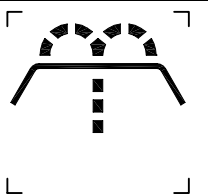
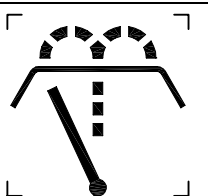
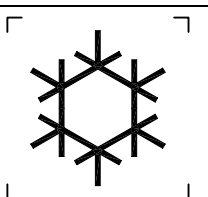

Reference number	Symbol form/shape	Symbol description/application	ISO/IEC registration number
7.6		Brake — On	0020
7.7		Brake — Off	0021

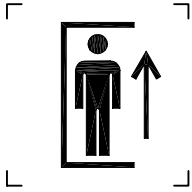
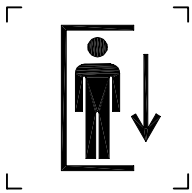
8 Cab symbols

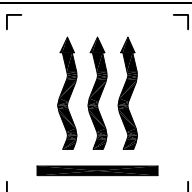
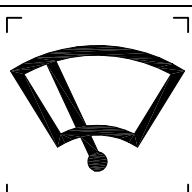
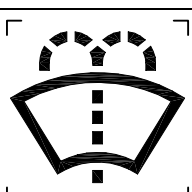
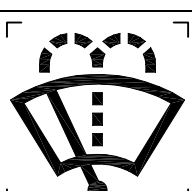
Reference number	Symbol form/shape	Symbol description/application	ISO/IEC registration number
8.1		Cab roof — Demister/defroster	2385
8.2		Cab roof — Wiper	2387
8.3		Cab roof — Washer	2386
8.4		Cab roof — Washer and wiper	2388
8.5		Cooling/air conditioning	0027

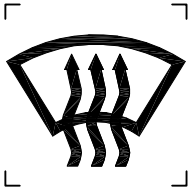
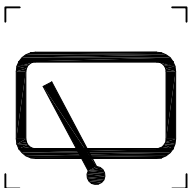
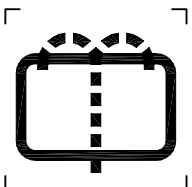
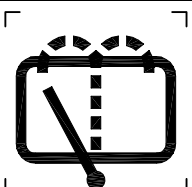
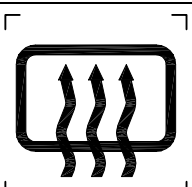
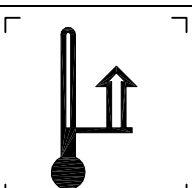
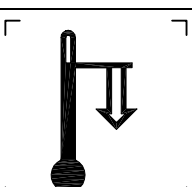
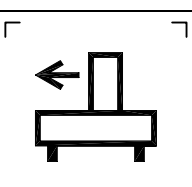
Reference number	Symbol form/shape	Symbol description/application	ISO/IEC registration number
8.6		Elevating operator position — Raise	2340
8.7		Elevating operator position — Lower	2339
8.8		Seatbelt — Lap and shoulder belt	0249
8.9		Seatbelt — Lap belt only	1702
8.10		Interior heating	0637
8.11		Windscreen/windshield wiper	0086
8.12		Windscreen/windshield washer	0088
8.13		Windscreen/windshield washer and wiper	0087

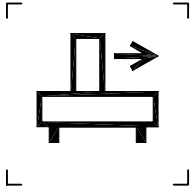
Reference number	Symbol form/shape	Symbol description/application	ISO/IEC registration number
8.14		Windscreen/windshield demister/defroster	0635
8.15		Rear window wiper	0097
8.16		Rear window washer	0099
8.17		Rear window washer and wiper	0098
8.18		Rear window demister/defroster	0636
8.19		Temperature — Increasing	0035
8.20		Temperature — Decreasing	0036
8.21		Sideloader cab — Traverse left	2382

Reference number	Symbol form/shape	Symbol description/application	ISO/IEC registration number
8.22		Sideloader cab — Traverse right	2383
8.23		Seat adjustment — Longitudinal	1428
8.24		Seat height adjustment	1430

9 Driving controls symbols

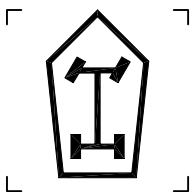
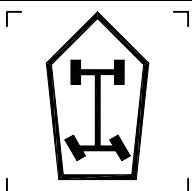
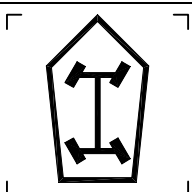
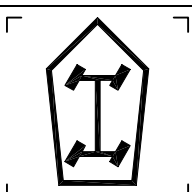
Reference number	Symbol form/shape	Symbol description/application	ISO/IEC registration number
9.1		2-wheel steering — Front (Powered industrial trucks)	2391
9.2		2-wheel steering — Rear (Powered industrial trucks)	2392
9.3		All-(4)-wheel steering (Powered industrial trucks)	2393
9.4		Crab steering (Powered industrial trucks)	2394

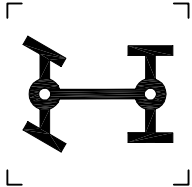
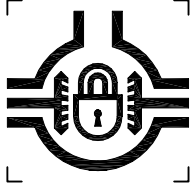
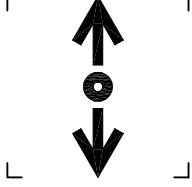
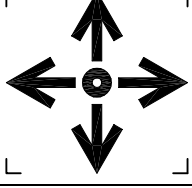
Reference number	Symbol form/shape	Symbol description/application	ISO/IEC registration number
9.5		Axle connect — All wheel drive [Add symbols for "on" and "off" or "engage" and "disengage" as needed.]	1203
9.6		Differential lock [Add symbols for "on" and "off" as needed.]	1662
9.7		Operating direction — Forward/reverse	1436
9.8		Operating direction — Multiple direction	1703

10 Engine symbols

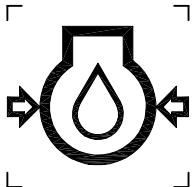
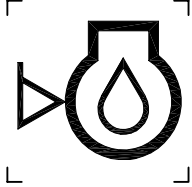
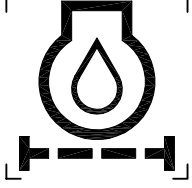
Reference number	Symbol form/shape	Symbol description/application	ISO/IEC registration number
10.1		Engine lubricating oil — Pressure	1374
10.2		Engine lubricating oil — Level	1373
10.3		Engine lubricating oil — Filter	1376

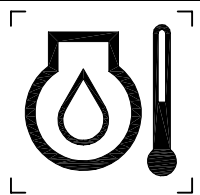
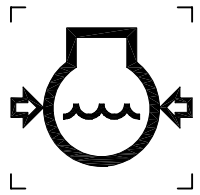
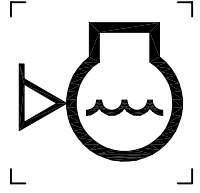
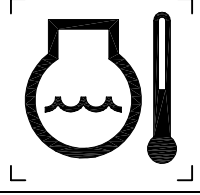
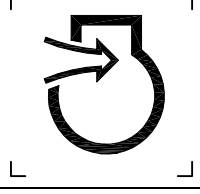
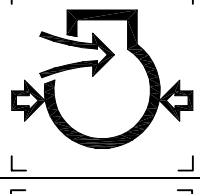
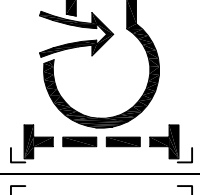
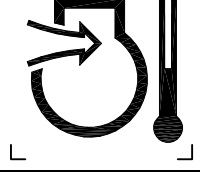

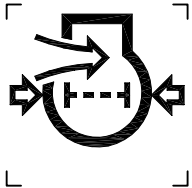
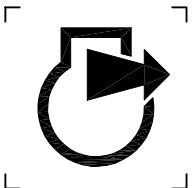
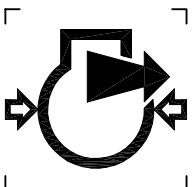
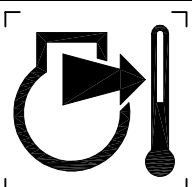
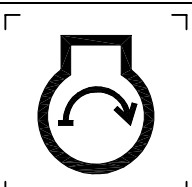
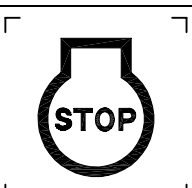
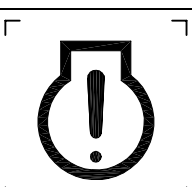
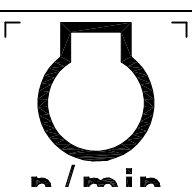
Reference number	Symbol form/shape	Symbol description/application	ISO/IEC registration number
10.4		Engine lubricating oil — Temperature	1375
10.5		Engine coolant — Pressure	1379
10.6		Engine coolant — Level	1378
10.7		Engine coolant — Temperature	1380
10.8		Engine combustion air	1381
10.9		Engine combustion air — Pressure	1382
10.10		Engine combustion air — Filter	1170
10.11		Engine combustion air — Temperature	1383

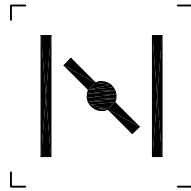
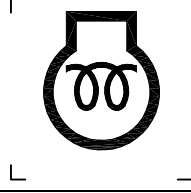
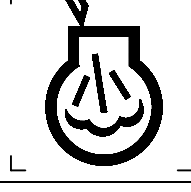
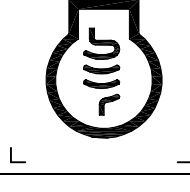
Reference number	Symbol form/shape	Symbol description/application	ISO/IEC registration number
10.12		Engine air filter — Pressure	2395
10.13		Engine exhaust gas	1384
10.14		Engine exhaust gas — Pressure	1385
10.15		Engine exhaust gas — Temperature	1386
10.16		Engine — Start	1387
10.17		Engine — Stop	1388
10.18		Engine — Failure/malfunction	1371
10.19		Engine — Rotational speed/frequency	1389



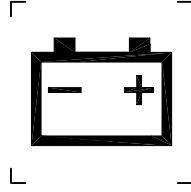
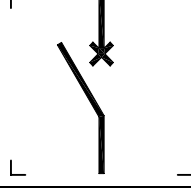
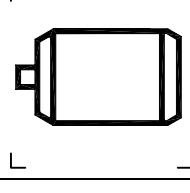

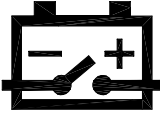
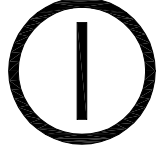
Reference number	Symbol form/shape	Symbol description/application	ISO/IEC registration number
10.20		Choke (cold starting aid)	0243
10.21		Electrical preheat (low temperature start aid)	1704
10.22		Gas injection (low temperature start aid)	1547
10.23		Engine — Water jacket heater	2384





11 Electrical system symbols

Reference number	Symbol form/shape	Symbol description/application	ISO/IEC registration number
11.1		Battery charging condition	0247
11.2		Circuit breaker	2400
11.3		Electric motor	0011

Reference number	Symbol form/shape	Symbol description/application	ISO/IEC registration number
11.4		Battery power — Disconnect	2063
11.5		On/off	5010
11.6		Horn	0244

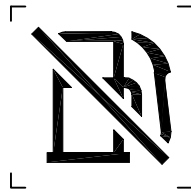
12 Fuel symbols

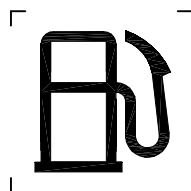
Reference number	Symbol form/shape	Symbol description/application	ISO/IEC registration number
12.1		Fuel — Pressure	1392
12.2		Fuel — Level	1551
12.3		Fuel — Filter	1393
12.4		Fuel — Temperature	1394

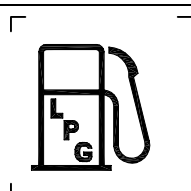
Reference number	Symbol form/shape	Symbol description/application	ISO/IEC registration number
12.5		Fuel shut-off [Not to be used as engine stop symbol.]	1395
12.6		Diesel (compression-ignition) fuel	1541
12.7		Gasoline (petrol) fuel	0245
12.8		Unleaded fuel only	0237
12.9		LPG fuel	2489

13 Transmission symbols

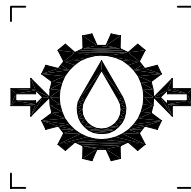
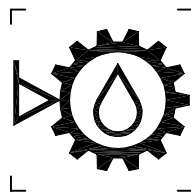

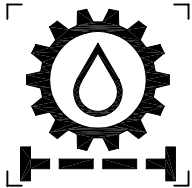
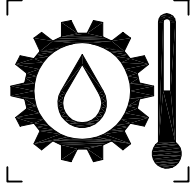
Reference number	Symbol form/shape	Symbol description/application	ISO/IEC registration number
13.1		Transmission oil — Pressure	1167
13.2		Transmission oil — Level	1398



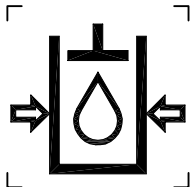
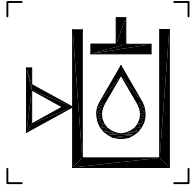
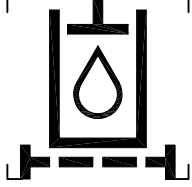
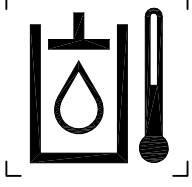

Reference number	Symbol form/shape	Symbol description/application	ISO/IEC registration number
13.3		Transmission oil — Filter	1169
13.4		Transmission oil — Temperature	1168

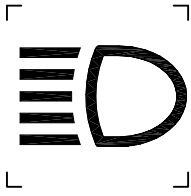
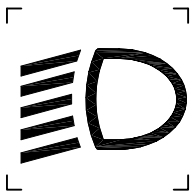
14 Hydraulic system symbols

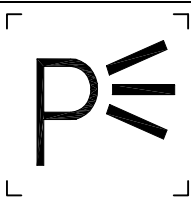
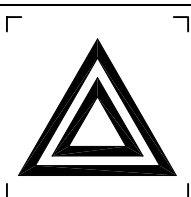
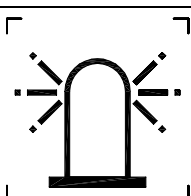
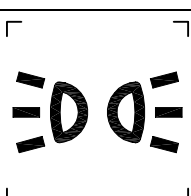
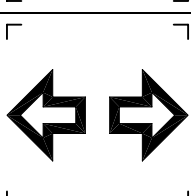
Reference number	Symbol form/shape	Symbol description/application	ISO/IEC registration number
14.1		Hydraulic oil — Pressure	1413
14.2		Hydraulic oil — Level	1412
14.3		Hydraulic oil — Filter	1415
14.4		Hydraulic oil — Temperature	1414

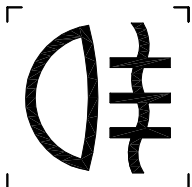

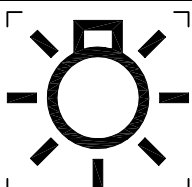

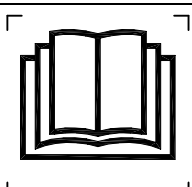
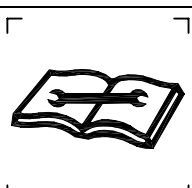

15 Lighting symbols

Reference number	Symbol form/shape	Symbol description/application	ISO/IEC registration number
15.1		Headlights — Main/high beam	0082
15.2		Headlights — Dipped/low beam	0083
15.3		Work light	1204
15.4		Parking lights	0240
15.5		Hazard warning lights	0085
15.6		Beacon/identifying light (rotating patrol light)	1141
15.7		Clearance/position lights	0456
15.8		Turn signals	0084

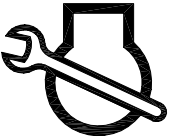
Reference number	Symbol form/shape	Symbol description/application	ISO/IEC registration number
15.9		Front fog lights [If one control is used for both front and rear fog lights, the symbol designated front fog lights shall be used.]	0633
15.10		Rear fog lights [If one control is used for both front and rear fog lights, the symbol designated front fog lights shall be used.]	0634
15.11		Spotlight	1700
15.12		Master lighting switch	5012
15.13		Interior lighting	1421

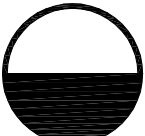
16 Maintenance symbols

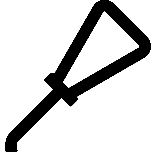
Reference number	Symbol form/shape	Symbol description/application	ISO/IEC registration number
16.1		Consult instruction book	0790
16.2		Read maintenance manual	1659

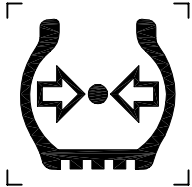
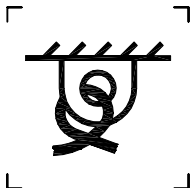

Reference number	Symbol form/shape	Symbol description/application	ISO/IEC registration number
16.3		Hourmeter/elapsed operating hours	1366
16.4		Service engine soon	2399
16.5		Volume — Empty	1563
16.6		Volume — Half-full	1564
16.7		Volume — Full	1565
16.8		Grease lubrication point	0787
16.9		Oil lubrication point	0391
16.10		Lift point	1368

Reference number	Symbol form/shape	Symbol description/application	ISO/IEC registration number
16.11		Tyre — Pressure	1435
16.12		Tie down point	2069

17 Load-handling control symbols

17.1 Blade symbols

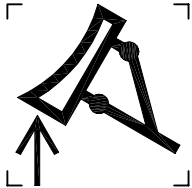
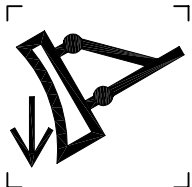
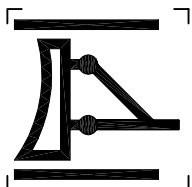
NOTE In symbols 17.1.7 and 17.1.8, the blade is viewed from the perspective of a person looking forward along the axis of the machine. In symbols 17.1.9 and 17.1.10, the blade is viewed from the perspective of a person looking at the blade from above the machine.

Reference number	Symbol form/shape	Symbol description/application	ISO/IEC registration number
17.1.1		Blade — Raise	1452
17.1.2		Blade — Lower	1453
17.1.3		Blade — Hold	1454
17.1.4		Blade — Float	1455

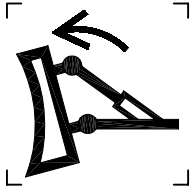
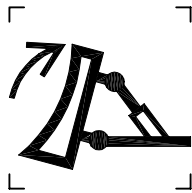
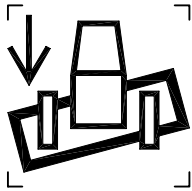
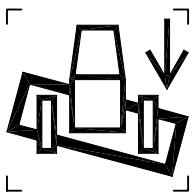
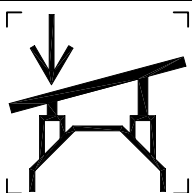
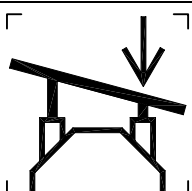
Reference number	Symbol form/shape	Symbol description/application	ISO/IEC registration number
17.1.5		Blade — Pitch forward	1461
17.1.6		Blade — Pitch rearward	1460
17.1.7		Blade — Tilt left	1457
17.1.8		Blade — Tilt right	1456
17.1.9		Blade — Angle left	1459
17.1.10		Blade — Angle right	1458

17.2 Bucket symbols

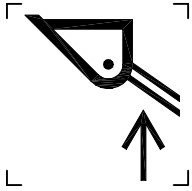
Reference number	Symbol form/shape	Symbol description/application	ISO/IEC registration number
17.2.1		Bucket — Raise	1438

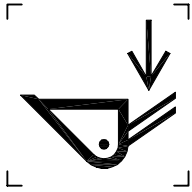
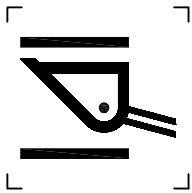
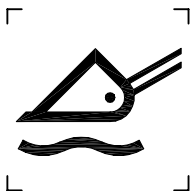
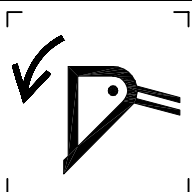
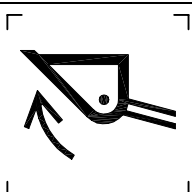
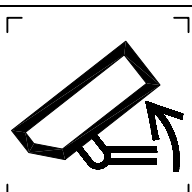
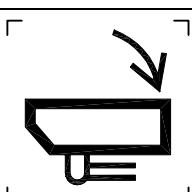
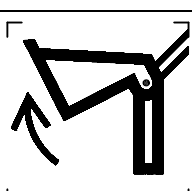
Reference number	Symbol form/shape	Symbol description/application	ISO/IEC registration number
17.2.2		Bucket — Lower	1439
17.2.3		Bucket — Hold	1440
17.2.4		Bucket — Float	1441
17.2.5		Bucket — Dump	1442
17.2.6		Bucket — Rollback	1443
17.2.7		Side-dump bucket — Dump	1449
17.2.8		Side-dump bucket — Return	1450
17.2.9		Multi-purpose bucket — Open	1446

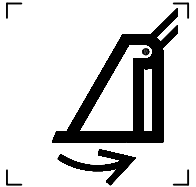
Reference number	Symbol form/shape	Symbol description/application	ISO/IEC registration number
17.2.10		Multi-purpose bucket — Close	1447

17.3 Stability control symbols

NOTE In symbols 17.3.1 to 17.3.4, the stabilizer is viewed from the perspective of a person looking forward along the axis of the machine.

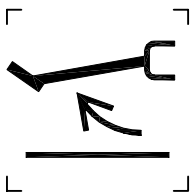
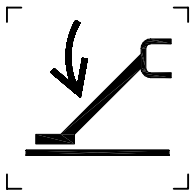
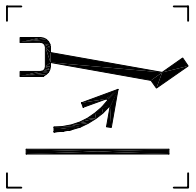
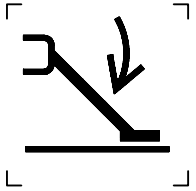
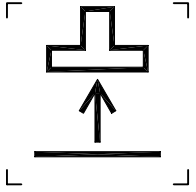
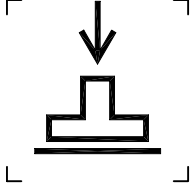
Reference number	Symbol form/shape	Symbol description/application	ISO/IEC registration number
17.3.1		Left stabilizer — Up/raise	2073
17.3.2		Left stabilizer — Down/lower	2074
17.3.3		Right stabilizer — Up/raise	1292
17.3.4		Right stabilizer — Down/lower	1291
17.3.5		Stabilizers — Up	1294
17.3.6		Stabilizers — Down	1293

17.4 Backhoe control symbols

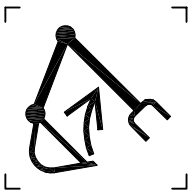
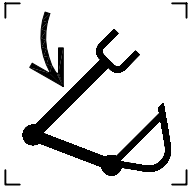
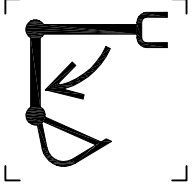
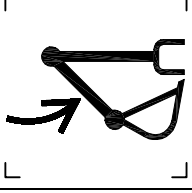
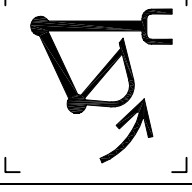
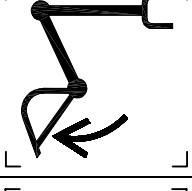
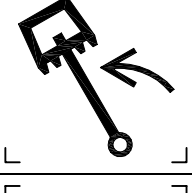
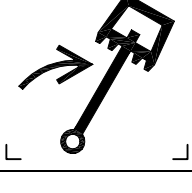
Reference number	Symbol form/shape	Symbol description/application	ISO/IEC registration number
17.4.1		Backhoe — Raise	1470
17.4.2		Backhoe — Lower	1469
17.4.3		Backhoe — Arm — Out	1474
17.4.4		Backhoe — Arm — In	1473
17.4.5		Backhoe — Bucket — Dig	1478
17.4.6		Backhoe — Bucket — Dump	1477
17.4.7		Backhoe — Swing left	1480
17.4.8		Backhoe — Swing right	1479

17.5 Additional load-handling control symbols

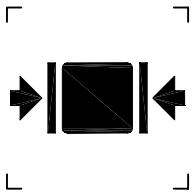
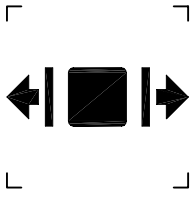
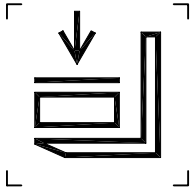
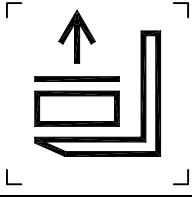
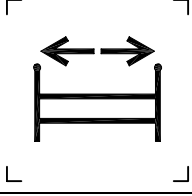
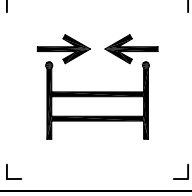
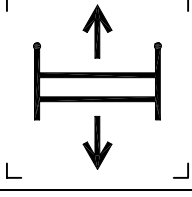
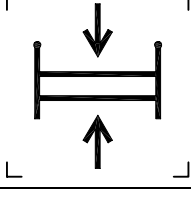
Reference number	Symbol form/shape	Symbol description/application	ISO/IEC registration number
17.5.1		Clamp	0631
17.5.2		Clamp — Release	2338
17.5.3		Load stabilizer — Clamp	1196
17.5.4		Load stabilizer — Release	1195
17.5.5		Container handling sidelif attachment — Extend laterally	2359
17.5.6		Container handling sidelif attachment — Retract laterally	2361
17.5.7		Container handling sidelif attachment — Extend vertically	2360
17.5.8		Container handling sidelif attachment — Retract vertically	2362

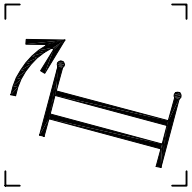
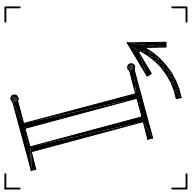
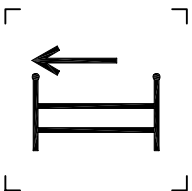
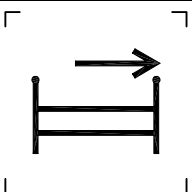
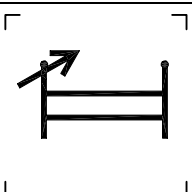
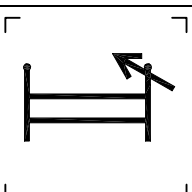
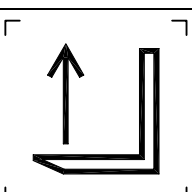
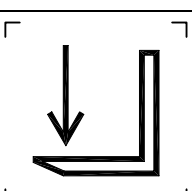
Reference number	Symbol form/shape	Symbol description/application	ISO/IEC registration number
17.5.9		Container handling sidelif attachment — Rotate clockwise	2363
17.5.10		Container handling sidelif attachment — Rotate anticlockwise	2364
17.5.11		Container handling sidelif attachment — Sideshift left	2365
17.5.12		Container handling sidelif attachment — Sideshift right	2366
17.5.13		Container handling sidelif attachment — Slew clockwise	2368
17.5.14		Container handling sidelif attachment — Slew anticlockwise	2367
17.5.15		Fork — Raise	1184
17.5.16		Fork — Lower	1183

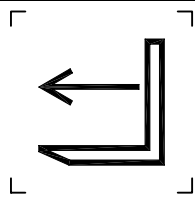
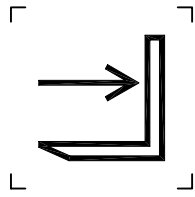
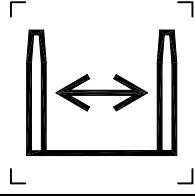
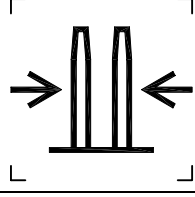
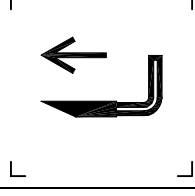
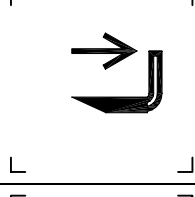
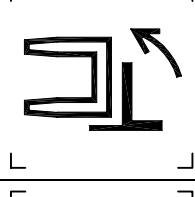
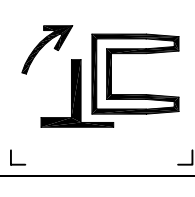
Reference number	Symbol form/shape	Symbol description/application	ISO/IEC registration number
17.5.17		Fork arm reach — Extend	1187
17.5.18		Fork arm reach — Retract	1188
17.5.19		Fork spread — Open	1191
17.5.20		Fork spread — Close	1192
17.5.21		Fork arm extension — Extend	2408
17.5.22		Fork arm extension — Retract	2409
17.5.23		Lateral stacking truck — Mechanism — Rotate left	2343
17.5.24		Lateral stacking truck — Mechanism — Rotate right	2344

Reference number	Symbol form/shape	Symbol description/application	ISO/IEC registration number
17.5.25		Lateral stacking truck — Mechanism — Sideshift right	2342
17.5.26		Lateral stacking truck — Mechanism — Sideshift left	2341
17.5.27		Load — Rotate clockwise	2346
17.5.28		Load — Rotate anticlockwise	2345
17.5.29		Piggy back arms — Block-stacking — In	2351
17.5.30		Piggy back arms — Block-stacking — Out	2352
17.5.31		Piggy back arms — Clamp	2348
17.5.32		Piggy back arms — Unclamp	2347

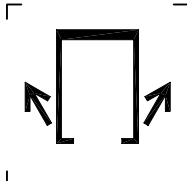
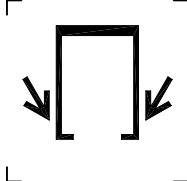
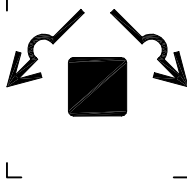
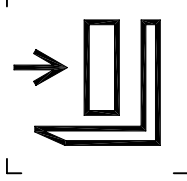
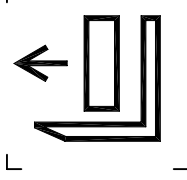
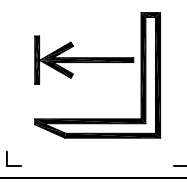
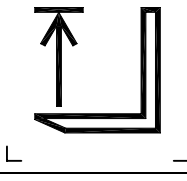
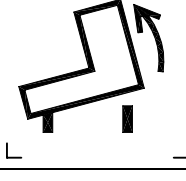
Reference number	Symbol form/shape	Symbol description/application	ISO/IEC registration number
17.5.33		Piggy back arms — Fold up	2349
17.5.34		Piggy back arms — Fold down	2350
17.5.35		Piggy back rotation limit — Override	2353
17.5.36		Push/pull attachment — Pull	2356
17.5.37		Push/pull attachment — Push	1197
17.5.38		Lift arm reach — Extend limited	2396
17.5.39		Lift arm lift — Limited movement	2397
17.5.40		Sideloader platform — Tilt up (forward)	2354

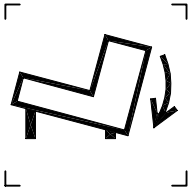
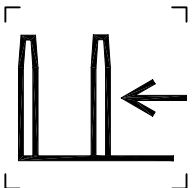
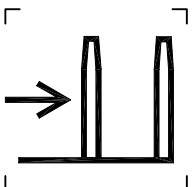
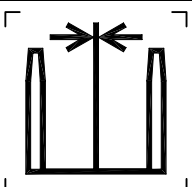
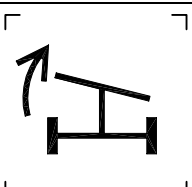
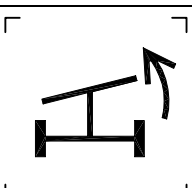
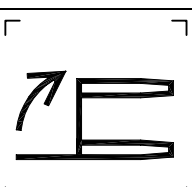
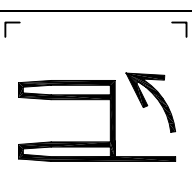
Reference number	Symbol form/shape	Symbol description/application	ISO/IEC registration number
17.5.41		Sideloader platform — Tilt down (back)	2355
17.5.42		Sideshift — Left	1189
17.5.43		Sideshift — Right	1190
17.5.44		Sideshift — Centralize	2398
17.5.45		Sway control/levelling — Clockwise	2390
17.5.46		Sway control/levelling — Anticlockwise	2389
17.5.47		Swing — Clockwise	1194
17.5.48		Swing — Anticlockwise	1193

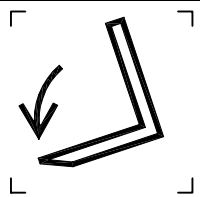
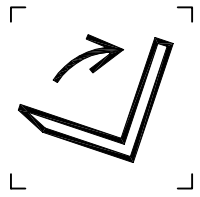
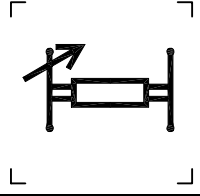
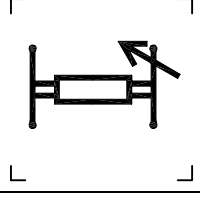
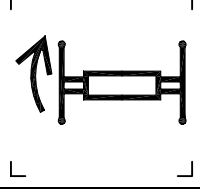
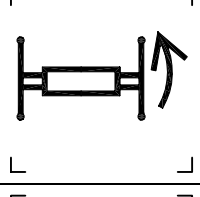
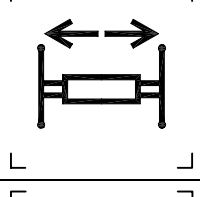
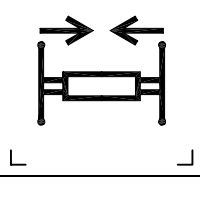
Reference number	Symbol form/shape	Symbol description/application	ISO/IEC registration number
17.5.49		Tilt — Forward	1185
17.5.50		Tilt — Rearward	1186
17.5.51		Toplift side tilt — Left-hand side up	2378
17.5.52		Toplift side tilt — Right-hand side up	2379
17.5.53		Toplift slew — Clockwise	2380
17.5.54		Toplift slew — Anticlockwise	2381
17.5.55		Toplift — Extend laterally	2372
17.5.56		Toplift — Retract laterally	2375

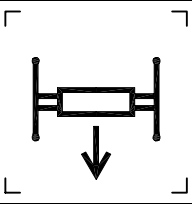
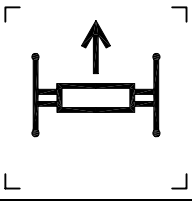
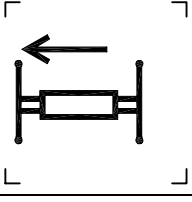
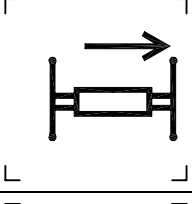
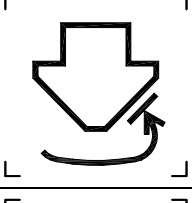
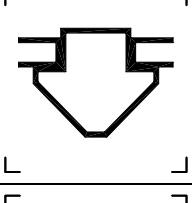
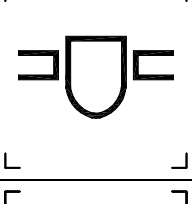
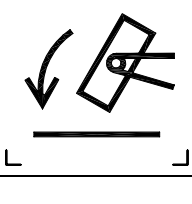
Reference number	Symbol form/shape	Symbol description/application	ISO/IEC registration number
17.5.57		Toplift — Reach in	2374
17.5.58		Toplift — Reach out	2373
17.5.59		Toplift — Sideshift left	2376
17.5.60		Toplift — Sideshift right	2377
17.5.61		Twistlocks — Located	2371
17.5.62		Twistlocks — Lock	2370
17.5.63		Twistlocks — Unlock	2369
17.5.64		Upender — Rotate forward	2357

www.iso.org

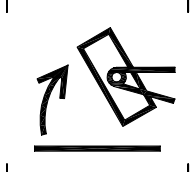
Reference number	Symbol form/shape	Symbol description/application	ISO/IEC registration number
17.5.65		Uppender — Rotate backward	2358

.....

Annex A (informative)

Symbols listed by reference number

Description	Reference No.	Page No.
Engine (RIC engine)	6.1	3
Transmission	6.2	3
Hydraulic system	6.3	3
Brake system	6.4	3
Oil	6.5	3
Water	6.6	3
Level indicator	6.7	3
Filter	6.8	3
Failure/malfunction	6.9	4
Temperature	6.10	4
On	6.11	4
Off	6.12	4
Centre of gravity	6.13	4
Engage	6.14	4
Disengage	6.15	4
Increase/positive/polarity	6.16	4
Decrease/negative/polarity	6.17	5
Electric energy	6.18	5
Fast run	6.19	5
Slow run	6.20	5
Fast (application example)	6.21	5
Slow (application example)	6.22	5
Lock	6.23	5
Steering	6.24	5
Ventilating/air circulating fan	6.25	5
Progressive variable — Rotation	6.26	6
Brake fluid	7.1	6
Brake system — Pressure	7.2	6
Brake system — Failure/malfunction	7.3	6
Parking brake	7.4	6
Worn brake linings	7.5	6
Brake — On	7.6	7
Brake — Off	7.7	7
Cab roof — Demister/defroster	8.1	7
Cab roof — Wiper	8.2	7
Cab roof — Washer	8.3	7
Cab roof — Washer and wiper	8.4	7
Cooling air conditioning	8.5	7
Elevating operator position — Raise	8.6	8
Elevating operator position — Lower	8.7	8
Seatbelt — Lap and shoulder belt	8.8	8
Seatbelt — Lap belt only	8.9	8
Interior heating	8.10	8
Windscreen/windshield wiper	8.11	8
Windscreen/windshield washer	8.12	8
Windscreen/windshield washer and wiper	8.13	8
Windscreen/windshield demister/defroster	8.14	9
Rear window wiper	8.15	9

Description	Reference No.	Page No.
Rear window washer	8.16	9
Rear window washer and wiper	8.17	9
Rear window demister/defroster	8.18	9
Temperature — Increasing	8.19	9
Temperature — Decreasing	8.20	9
Sideloader cab — Traverse left	8.21	9
Sideloader cab — Traverse right	8.22	10
Seat adjustment — Longitudinal	8.23	10
Seat height adjustment	8.24	10
Industrial truck 2-wheel steering — Front	9.1	10
Industrial truck 2-wheel steering — Rear	9.2	10
Industrial truck All (4)-wheel steering	9.3	10
Industrial truck — Crab steering	9.4	10
Axle connect — All-wheel drive	9.5	11
Differential lock	9.6	11
Operating direction — Forward/reverse	9.7	11
Operating direction — Multiple	9.8	11
Engine lubricating oil — Pressure	10.1	11
Engine lubricating oil — Level	10.2	11
Engine lubricating oil — Filter	10.3	11
Engine lubricating oil — Temperature	10.4	12
Engine coolant — Pressure	10.5	12
Engine coolant — Level	10.6	12
Engine coolant — Temperature	10.7	12
Engine combustion air	10.8	12
Engine combustion air — Pressure	10.9	12
Engine combustion air — Filter	10.10	12
Engine combustion air — Temperature	10.11	12
Engine air filter — Pressure	10.12	13
Engine exhaust gas	10.13	13
Engine exhaust gas — Pressure	10.14	13
Engine exhaust gas — Temperature	10.15	13
Engine — Start	10.16	13
Engine — Stop	10.17	13
Engine — Failure/malfunction	10.18	13
Engine — Rotational speed/frequency	10.19	13
Choke (cold starting aid)	10.20	14
Electrical preheat (low temperature start aid)	10.21	14
Gas injection (low temperature start aid)	10.22	14
Engine water jacket heater	10.23	14
Battery — Charging condition	11.1	14
Circuit breaker	11.2	14
Electric Motor	11.3	14
Battery power — disconnect	11.4	15
On/Off	11.5	15
Horn	11.6	15
Fuel — Pressure	12.1	15
Fuel — Level	12.2	15
Fuel — Filter	12.3	15
Fuel — Temperature	12.4	15
Fuel — Shut-off	12.5	16
Diesel (compression-ignition) fuel	12.6	16
Gasoline (petrol)	12.7	16
Unleaded fuel only	12.8	16
LPG fuel	12.9	16
Transmission oil — Pressure	13.1	16
Transmission oil — Level	13.2	16

Description	Reference No.	Page No.
Transmission oil — Filter	13.3	17
Transmission oil — Temperature	13.4	17
Hydraulic oil — Pressure	14.1	17
Hydraulic oil — Level	14.2	17
Hydraulic oil — Filter	14.3	17
Hydraulic oil — Temperature	14.4	17
Headlights — Main/high beam	15.1	18
Headlights — Dipped/low beam	15.2	18
Work light	15.3	18
Parking lights	15.4	18
Hazard warning lights	15.5	18
Beacon/identifying light (rotating patrol light)	15.6	18
Clearance/position lights	15.7	18
Turn signals	15.8	18
Front fog lights	15.9	19
Rear fog lights	15.10	19
Spotlight	15.11	19
Master lighting switch	15.12	19
Interior lighting	15.13	19
Consult instruction book	16.1	19
Read maintenance manual	16.2	19
Hourmeter/elapsed operating hours	16.3	20
Service engine soon	16.4	20
Volume — Empty	16.5	20
Volume — Half-full	16.6	20
Volume — Full	16.7	20
Grease lubrication point	16.8	20
Oil lubrication point	16.9	20
Lift point	16.10	20
Tyre — Pressure	16.11	21
Tie down point	16.12	21
Blade — Raise	17.1.1	21
Blade — Lower	17.1.2	21
Blade — Hold	17.1.3	21
Blade — Float	17.1.4	21
Blade — Pitch forward	17.1.5	22
Blade — Pitch rearward	17.1.6	22
Blade — Tilt left	17.1.7	22
Blade — Tilt right	17.1.8	22
Blade — Angle left	17.1.9	22
Blade — Angle right	17.1.10	22
Bucket — Raise	17.2.1	22
Bucket — Lower	17.2.2	23
Bucket — Hold	17.2.3	23
Bucket — Float	17.2.4	23
Bucket — Dump	17.2.5	23
Bucket — Rollback	17.2.6	23
Side dump bucket — Dump	17.2.7	23
Side dump bucket — Return	17.2.8	23
Multi-purpose bucket — Open	17.2.9	23
Multi-purpose bucket — Close	17.2.10	24
Left stabilizer — Up/raise	17.3.1	24
Left stabilizer — Down/lower	17.3.2	24
Right stabilizer — Up/raise	17.3.3	24
Right stabilizer — Down/lower	17.3.4	24
Stabilizers — Up	17.3.5	24
Stabilizers — Down	17.3.6	24

Description	Reference No.	Page No.
Backhoe — Raise	17.4.1	25
Backhoe — Lower	17.4.2	25
Backhoe — Arm — Out	17.4.3	25
Backhoe — Arm — In	17.4.4	25
Backhoe — Bucket — Dig	17.4.5	25
Backhoe — Bucket — Dump	17.4.6	25
Backhoe — Swing left	17.4.7	25
Backhoe — Swing right	17.4.8	25
Clamp	17.5.1	26
Clamp — Release	17.5.2	26
Load stabilizer — Clamp	17.5.3	26
Load stabilizer — Release	17.5.4	26
Container handling sidelifift attachment — Extend laterally	17.5.5	26
Container handling sidelifift attachment — Retract laterally	17.5.6	26
Container handling sidelifift attachment — Extend vertically	17.5.7	26
Container handling sidelifift attachment — Retract vertically	17.5.8	26
Container handling sidelifift attachment — Rotate clockwise	17.5.9	27
Container handling sidelifift attachment — Rotate anticlockwise	17.5.10	27
Container handling sidelifift attachment — Sideshift left	17.5.11	27
Container handling sidelifift attachment — Sideshift right	17.5.12	27
Container handling sidelifift attachment — Slew clockwise	17.5.13	27
Container handling sidelifift attachment — Slew anticlockwise	17.5.14	27
Fork — Raise	17.5.15	27
Fork — Lower	17.5.16	27
Fork arm reach — Extend	17.5.17	28
Fork arm reach — Retract	17.5.18	28
Fork spread — Open	17.5.19	28
Fork spread — Close	17.5.20	28
Fork arm extension — Extend	17.5.21	28
Fork arm extension — Retract	17.5.22	28
Lateral stacking truck — Mechanism — Rotate left	17.5.23	28
Lateral stacking truck — Mechanism — Rotate right	17.5.24	28
Lateral stacking truck — Mechanism — Sideshift left	17.5.25	29
Lateral stacking truck — Mechanism — Sideshift right	17.5.26	29
Load — Rotate clockwise	17.5.27	29
Load — Rotate anticlockwise	17.5.28	29
Piggy back arms — Block-stacking — In	17.5.29	29
Piggy back arms — Block-stacking — Out	17.5.30	29
Piggy back arms — Clamp	17.5.31	29
Piggy back arms — Unclamp	17.5.32	29
Piggy back arms — Fold up	17.5.33	30
Piggy back arms — Fold down	17.5.34	30
Piggy back rotational limit — Override	17.5.35	30
Push/pull attachment — Pull	17.5.36	30
Push/pull attachment — Push	17.5.37	30
Lift arm reach — Extend limited	17.5.38	30
Lift arm lift — Limited movement	17.5.39	30
Sideloader platform — Tilt up (forward)	17.5.40	30
Sideloader platform — Tilt down (back)	17.5.41	31
Sideshift — Left	17.5.42	31
Sideshift — Right	17.5.43	31
Sideshift — Centralize	17.5.44	31
Sway control/levelling — Clockwise	17.5.45	31

Description	Reference No.	Page No.
Sway control/levelling — Anticlockwise	17.5.46	31
Swing — Clockwise	17.5.47	31
Swing — Anticlockwise	17.5.48	31
Tilt — Forward	17.5.49	32
Tilt — Rearward	17.5.50	32
Toplift side tilt — Left-hand side up	17.5.51	32
Toplift side tilt — Right-hand side up	17.5.52	32
Toplift slew — Clockwise	17.5.53	32
Toplift slew — Anticlockwise	17.5.54	32
Toplift — Extend laterally	17.5.55	32
Toplift — Retract laterally	17.5.56	32
Toplift — Reach in	17.5.57	33
Toplift — Reach out	17.5.58	33
Toplift — Sideshift left	17.5.59	33
Toplift — Sideshift right	17.5.60	33
Twistlocks — Located	17.5.61	33
Twistlocks — Lock	17.5.62	33
Twistlocks — Unlock	17.5.63	33
Upraiser — Rotate forward	17.5.64	33
Upraiser — Rotate backward	17.5.65	34

Annex B (informative)

Symbols listed by key identifier noun

Description	Reference No.	Page No.
Axle connect — All-wheel drive	9.5	11
Backhoe — Arm — In	17.4.4	25
Backhoe — Arm — Out	17.4.3	25
Backhoe — Bucket — Dig	17.4.5	25
Backhoe — Bucket — Dump	17.4.6	25
Backhoe — Lower	17.4.2	25
Backhoe — Raise	17.4.1	25
Backhoe — Swing left	17.4.7	25
Backhoe — Swing right	17.4.8	25
Battery/charging condition	11.1	14
Battery power — Disconnect	11.4	15
Beacon/identifying light (rotating patrol light)	15.6	15
Blade — Angle left	17.1.9	22
Blade — Angle right	17.1.10	22
Blade — Float	17.1.4	21
Blade — Hold	17.1.3	21
Blade — Lower	17.1.2	21
Blade — Pitch forward	17.1.5	22
Blade — Pitch rearward	17.1.6	22
Blade — Raise	17.1.1	21
Blade — Tilt left	17.1.7	22
Blade — Tilt right	17.1.8	22
Brake — Off	7.7	7
Brake — On	7.6	7
Brake fluid	7.1	6
Brake system	6.4	3
Brake system — Failure/malfunction	7.3	6
Brake system — pressure	7.2	6
Bucket — Dump	17.2.5	23
Bucket — Float	17.2.4	23
Bucket — Hold	17.2.3	23
Bucket — Lower	17.2.2	23
Bucket — Raise	17.2.1	22
Bucket — Rollback	17.2.6	23
Cab roof — Demister/defroster	8.1	7
Cab roof — Washer	8.3	7
Cab roof — Washer and wiper	8.4	7
Cab roof — Wiper	8.2	7
Centre of gravity	6.13	4
Choke (cold starting aid)	10.20	14
Circuit breaker	11.2	14
Clamp	17.5.1	26
Clamp — Release	17.5.2	26
Clearance/position lights	15.7	18
Consult instruction book	16.1	19
Container handling sidelifift attachment — Extend laterally	17.5.5	26
Container handling sidelifift attachment — Extend vertically	17.5.7	26
Container handling sidelifift attachment — Retract laterally	17.5.6	26

Description	Reference No.	Page No.
Container handling sidelif attachment — Retract vertically	17.5.8	26
Container handling sidelif attachment — Rotate anticlockwise	17.5.10	27
Container handling sidelif attachment — Rotate clockwise	17.5.9	27
Container handling sidelif attachment — Sideshift left	17.5.11	27
Container handling sidelif attachment — Sideshift right	17.5.12	27
Container handling sidelif attachment — Slew anti - clockwise	17.5.14	27
Container handling sidelif attachment — Slew clockwise	17.5.13	27
Cooling air — Conditioning	8.5	7
Decrease/negative/polarity	6.17	5
Diesel (compression-ignition) fuel	12.6	16
Differential lock	9.6	11
Disengage	6.15	4
Electric energy	6.18	5
Electric motor	11.3	14
Electrical preheat (low temperature start aid)	10.21	14
Elevating operator position — Lower	8.7	8
Elevating operator position — Raise	8.6	8
Engage	6.14	4
Engine (RIC engine)	6.1	3
Engine — Failure/malfunction	10.18	13
Engine — Rotational speed/frequency	10.19	13
Engine — Start	10.16	13
Engine — Stop	10.17	13
Engine air filter — Pressure	10.12	13
Engine combustion air	10.8	12
Engine combustion air — Filter	10.10	12
Engine combustion air — Pressure	10.9	12
Engine combustion air — Temperature	10.11	12
Engine coolant — Level	10.6	12
Engine coolant — Pressure	10.5	12
Engine coolant — Temperature	10.7	12
Engine exhaust gas — Pressure	10.14	13
Engine exhaust gas — Temperature	10.15	13
Engine exhaust gas	10.13	13
Engine lubricating oil — Filter	10.3	11
Engine lubricating oil — Level	10.2	11
Engine lubricating oil — Pressure	10.1	11
Engine lubricating oil — Temperature	10.4	12
Engine — Water jacket heater	10.23	14
Failure/malfunction	6.9	4
Fast (application example)	6.21	5
Fast run	6.19	5
Filter	6.8	3
Fork — Lower	17.5.16	27
Fork — Raise	17.5.15	27
Fork arm reach — Extend	17.5.17	28
Fork arm extension — Extend	17.5.21	28
Fork arm reach — Retract	17.5.18	28
Fork arm extension — Retract	17.5.22	28
Fork spread — Close	17.5.20	28
Fork spread — Open	17.5.19	28
Front fog lights	15.9	19
Fuel — Filter	12.3	15

Description	Reference No.	Page No.
Fuel — Level	12.2	15
Fuel — Pressure	12.1	15
Fuel — Shut-off	12.5	16
Fuel — Temperature	12.4	15
Gas injection (low temperature start aid)	10.22	14
Gasoline (petrol) fuel	12.7	16
Grease lubrication point	16.8	20
Hazard warning lights	15.5	20
Headlights — Dipped/low beam	15.2	18
Headlights — Main/high beam	15.1	18
Horn	11.6	15
Hourmeter/elapsed operating hours	16.3	20
Hydraulic system	6.3	3
Hydraulic oil — Filter	14.3	17
Hydraulic oil — Level	14.2	17
Hydraulic oil — Pressure	14.1	17
Hydraulic oil — Temperature	14.4	17
Increase/Positive polarity	6.16	4
Industrial truck — Crab steering	9.4	10
Industrial truck — 2-wheel steering — Front	9.1	10
Industrial truck — 2-wheel steering — Rear	9.2	10
Industrial truck — All (4)-wheel steering	9.3	10
Interior heating	8.10	8
Interior lighting	15.13	19
Lateral stacking truck — Mechanism — Rotate left	17.5.23	28
Lateral stacking truck — Mechanism — Rotate right	17.5.24	28
Lateral stacking truck — Mechanism — Sideshift right	17.5.25	29
Lateral stacking truck — Mechanism — Sideshift left	17.5.26	29
Left stabilizer — Down/lower	17.3.2	24
Left stabilizer — Up/raise	17.3.1	24
Level indicator	6.7	3
Lift arm lift — Limited movement	17.5.39	30
Lift arm reach — Extend limited	17.5.38	30
Lift point	16.10	20
Load — Rotate anticlockwise	17.5.28	29
Load — Rotate clockwise	17.5.27	29
Load stabilizer — Clamp	17.5.3	26
Load stabilizer — Release	17.5.4	26
Lock	6.23	5
LPG fuel	12.9	16
Master lighting switch	15.12	19
Multi-purpose bucket — Close	17.2.10	24
Multi-purpose bucket — Open	17.2.9	23
Off	6.12	4
Oil	6.5	3
Oil lubrication point	16.9	20
On	6.11	4
On/Off	11.5	15
Operating direction — Forward/reverse	9.7	11
Operating direction — Multiple direction	9.8	11
Parking brake	7.4	6
Parking lights	15.4	18
Piggy back arms — Block-stacking — Out	17.5.30	29
Piggy back arms — Block-stacking — In	17.5.29	29
Piggy back arms — Clamp	17.5.31	20
Piggy back arms — Fold down	17.5.34	30
Piggy back arms — Fold up	17.5.33	30

Description	Reference No.	Page No.
Piggy back arms — Unclamp	17.5.32	29
Piggy back rotational limit — Override	17.5.35	30
Progressively variable — Rotation	6.26	6
Push/pull attachment — Pull	17.5.36	30
Push/pull attachment — Push	17.5.37	30
Read maintenance manual	16.2	19
Rear fog lights	15.10	19
Rear window demister/defroster	8.18	9
Rear window washer	8.16	9
Rear window washer and wiper	8.17	9
Rear window wiper	8.15	9
Right stabilizer — Down/lower	17.3.4	24
Right stabilizer — Up/raise	17.3.3	24
Seat height adjustment	8.24	10
Seat adjustment — Longitudinal	8.23	10
Seatbelt — Lap and shoulder belt	8.8	8
Seatbelt — Lap belt only	8.9	8
Service engine soon	16.4	20
Side-dump bucket — Dump	17.2.7	23
Side-dump bucket — Return	17.2.8	23
Sideloader cab — Traverse left	8.21	9
Sideloader cab — Traverse right	8.22	10
Sideloader platform — Tilt down (back)	17.5.41	31
Sideloader platform — Tilt up (forward)	17.5.40	30
Sideshift — Centralize	17.5.44	31
Sideshift — Left	17.5.42	31
Sideshift — Right	17.5.43	31
Slow (application example)	6.22	5
Slow run	6.20	5
Spotlight	15.11	19
Stabilizers — Down	17.3.6	24
Stabilizers — Up	17.3.5	24
Steering	6.24	5
Sway control/levelling — Anticlockwise	17.5.46	31
Sway control/levelling — Clockwise	17.5.45	31
Swing — Anticlockwise	17.5.48	31
Swing — Clockwise	17.5.47	31
Temperature	6.10	4
Temperature — Decreasing	8.20	9
Temperature — Increasing	8.19	9
Tie down point	16.12	21
Tilt — Forward	17.5.49	32
Tilt — Rearward	17.5.50	32
Toplift — Extend laterally	17.5.55	32
Toplift — Reach in	17.5.57	33
Toplift — Reach out	17.5.58	33
Toplift — Retract laterally	17.5.56	32
Toplift — Sideshift left	17.5.59	32
Toplift — Sideshift right	17.5.60	32
Toplift side tilt — Left-hand side up	17.5.51	31
Toplift side tilt — Right-hand side up	17.5.52	32
Toplift slew — Anticlockwise	17.5.54	32
Toplift slew — Clockwise	17.5.53	32
Transmission	6.2	3
Transmission oil — Filter	13.3	17
Transmission oil — Level	13.2	16
Transmission oil — Temperature	13.4	17

Description	Reference No.	Page No.
Transmission oil — Pressure	13.1	16
Turn signals	15.8	18
Twistlocks — Lock	17.5.62	33
Twistlocks — Located	17.5.61	33
Tyre — Pressure	16.11	21
Unleaded fuel only	12.8	16
Twistlock — Unlock	17.5.63	33
Uprinder — Rotate backward	17.5.65	34
Uprinder — Rotate forward	17.5.64	34
Ventilating/air circulating fan	6.25	5
Volume — Empty	16.5	20
Volume — Full	16.7	20
Volume — Half-full	16.6	20
Water	6.6	3
Windscreen/windshield demister/defroster	8.14	9
Windscreen/windshield washer	8.12	8
Windscreen/windshield washer and wiper	8.13	8
Windscreen/windshield wiper	8.11	8
Work light	15.3	18
Worn brake linings	7.5	6

Bibliography

- [1] ISO 7000:1989, *Graphical symbols for use on equipment — Index and synopsis*.
- [2] IEC 417:1973, *Graphical symbols for use on equipment — Index, survey and compilation of the single sheets, and its supplements* (IEC 417A:1974, IEC 417B:1975, IEC 417C:1977, IEC 417D:1978, IEC 417E:1980, IEC 417F:1982, IEC 417G:1985, IEC 417H:1987, IEC 417J:1990, IEC 417K:1991, IEC 417L:1993, IEC 417M:1994).

ICS 01.080.20; 53.060

Price based on 45 pages
