

---

---

**Iron ores for blast furnace and direct  
reduction feedstocks — Determination of  
the tumble and abrasion indices**

*Minerais de fer pour charges de hauts fourneaux et pour procédés par  
réduction directe — Détermination des indices de cohésion et  
d'abrasion*



Reference number  
ISO 3271:2007(E)

© ISO 2007

**PDF disclaimer**

This PDF file may contain embedded typefaces. In accordance with Adobe's licensing policy, this file may be printed or viewed but shall not be edited unless the typefaces which are embedded are licensed to and installed on the computer performing the editing. In downloading this file, parties accept therein the responsibility of not infringing Adobe's licensing policy. The ISO Central Secretariat accepts no liability in this area.

Adobe is a trademark of Adobe Systems Incorporated.

Details of the software products used to create this PDF file can be found in the General Info relative to the file; the PDF-creation parameters were optimized for printing. Every care has been taken to ensure that the file is suitable for use by ISO member bodies. In the unlikely event that a problem relating to it is found, please inform the Central Secretariat at the address given below.



**COPYRIGHT PROTECTED DOCUMENT**

© ISO 2007

All rights reserved. Unless otherwise specified, no part of this publication may be reproduced or utilized in any form or by any means, electronic or mechanical, including photocopying and microfilm, without permission in writing from either ISO at the address below or ISO's member body in the country of the requester.

ISO copyright office  
Case postale 56 • CH-1211 Geneva 20  
Tel. + 41 22 749 01 11  
Fax + 41 22 749 09 47  
E-mail [copyright@iso.org](mailto:copyright@iso.org)  
Web [www.iso.org](http://www.iso.org)

Published in Switzerland

# Contents

Page

Foreword.....	iv
Introduction .....	v
1 Scope .....	1
2 Normative references .....	1
3 Terms and definitions.....	1
4 Principle .....	1
5 Sampling, sample preparation and preparation of test portions.....	2
6 Apparatus .....	2
7 Procedure .....	3
8 Expression of results .....	3
9 Test report .....	4
10 Verification .....	5
Annex A (normative) Flowsheet of the procedure for the acceptance of test results .....	6

## Foreword

ISO (the International Organization for Standardization) is a worldwide federation of national standards bodies (ISO member bodies). The work of preparing International Standards is normally carried out through ISO technical committees. Each member body interested in a subject for which a technical committee has been established has the right to be represented on that committee. International organizations, governmental and non-governmental, in liaison with ISO, also take part in the work. ISO collaborates closely with the International Electrotechnical Commission (IEC) on all matters of electrotechnical standardization.

International Standards are drafted in accordance with the rules given in the ISO/IEC Directives, Part 2.

The main task of technical committees is to prepare International Standards. Draft International Standards adopted by the technical committees are circulated to the member bodies for voting. Publication as an International Standard requires approval by at least 75 % of the member bodies casting a vote.

Attention is drawn to the possibility that some of the elements of this document may be the subject of patent rights. ISO shall not be held responsible for identifying any or all such patent rights.

ISO 3271 was prepared by Technical Committee ISO/TC 102, *Iron ore and direct reduced iron*, Subcommittee SC 3, *Physical testing*.

This fourth edition cancels and replaces the third edition (ISO 3271:1995), which has been revised to homogenise with other physical test standards.

## Introduction

This International Standard concerns one of a number of physical test methods that have been developed to measure various physical parameters and to evaluate the behaviour of iron ores, including reducibility, disintegration, crushing strength, apparent density, etc. This method was developed to provide a uniform procedure, validated by collaborative testing, to facilitate comparisons of tests made in different laboratories.

The results of this test should be considered in conjunction with other tests used to evaluate the quality of iron ores as feedstocks for blast furnace and direct reduction processes.

This International Standard may be used to provide test results as part of a production quality-control system, as a basis of a contract, or as part of a research project.

.....

# Iron ores for blast furnace and direct reduction feedstocks — Determination of the tumble and abrasion indices

**CAUTION** — This International Standard may involve hazardous operations and equipment. This standard does not purport to address all of the safety issues associated with its use. It is the responsibility of the user of this International Standard to establish appropriate safety and health practices and to determine the applicability of regulatory limitations prior to its use.

## 1 Scope

This International Standard specifies a method to provide a relative measure for evaluating the resistance of iron ores to size degradation by impact and abrasion. It covers the determination of the tumble and abrasion indices.

This International Standard is applicable to lump ores, sinters and hot-bonded pellets.

## 2 Normative references

The following referenced documents are indispensable for the application of this document. For dated references, only the edition cited applies. For undated references, the latest edition of the referenced document (including any amendments) applies.

ISO 3082:2000<sup>1)</sup>, *Iron ores — Sampling and sample preparation procedures*

ISO 3310-1:2000, *Test sieves — Technical requirements and testing — Part 1: Test sieves of metal wire cloth*

ISO 3310-2:1999, *Test sieves — Technical requirements and testing — Part 2: Test sieves of perforated metal plate*

ISO 4701:—<sup>2)</sup>, *Iron ores and direct reduced iron — Determination of size distribution by sieving*

ISO 11323:2002, *Iron ore and direct reduced iron — Vocabulary*

## 3 Terms and definitions

For the purposes of this document, the terms and definitions given in ISO 11323 apply.

## 4 Principle

The test portion is tumbled in a circular drum for a total of 200 revolutions, at 25 r/min. The product material is sieved with test sieves having square openings of 6,30 mm and 500 µm. The tumble index is expressed as the mass percentage of material greater than 6,30 mm, and the abrasion index as the mass percentage of material less than 500 µm.

---

1) Under revision to incorporate ISO 10836, *Iron ores — Method of sampling and sample preparation for physical testing*.

2) To be published. (Revision of ISO 4701:1999)

## 5 Sampling, sample preparation and preparation of test portions

### 5.1 Sampling and sample preparation

Sampling of a lot and preparation of a test sample shall be in accordance with ISO 3082.

The size range for pellets shall be  $-40,0 \text{ mm} + 6,30 \text{ mm}$ .

The size range for sinters and lump ores shall be  $-40,0 \text{ mm} + 10,0 \text{ mm}$ .

A test sample of at least 60 kg, on a dry basis, of the sized material shall be obtained.

Oven-dry the test sample to constant mass at  $105 \text{ }^\circ\text{C} \pm 5 \text{ }^\circ\text{C}$  and cool it to room temperature before preparation of the test portions.

NOTE Constant mass is achieved when the difference in mass between two subsequent measurements becomes less than 0,05 % of the initial mass of the test sample.

### 5.2 Preparation of test portions

The test portions shall be obtained from the test sample using the division methods given in ISO 3082.

For pellets, at least 4 test portions, each of  $15 \text{ kg} \pm 0,15 \text{ kg}$  mass shall be prepared.

For sinters and lump ores, the test sample shall be separated into 4 fractions by sieving through 25,0 mm, 16,0 mm and 10,0 mm sieves. From the material on the 3 sieves, at least 4 test portions, each of  $15 \text{ kg} \pm 0,15 \text{ kg}$  mass, shall be reconstituted by taking a proportionate mass of material from each of the 3 fractions. Register the mass of each test portion on its recipient label.

## 6 Apparatus

### 6.1 General

The test apparatus shall comprise:

- a) ordinary laboratory equipment, such as an oven, hand tools and safety equipment;
- b) a tumble drum and rotation equipment;
- c) test sieves;
- d) a weighing device.

**6.2 Tumble drum**, made of steel plate at least 5 mm in thickness, having an internal diameter of 1 000 mm and an internal length of 500 mm. Two equally spaced L-shaped steel lifters 50 mm flat  $\times$  50 mm high  $\times$  5 mm thick and 500 mm long shall be solidly attached longitudinally inside the drum by welding, in such a manner as to prevent accumulation of material between the lifter and drum. Each lifter shall be fastened so that it points towards the axis of the drum, with its attached leg pointing away from the direction of rotation, thus providing a clear unobstructed shelf for lifting the sample. The door shall be so constructed as to fit into the drum to form a smooth inner surface. During the test, the door shall be rigidly fastened and sealed to prevent loss of the sample. The drum shall be rotated on stub axles attached to its ends by flanges welded so as to provide smooth inner surfaces. The drum shall be replaced, in any case, when the thickness of the plate is reduced to 3 mm in any area. The lifters shall be replaced when the height of the shelf is reduced to less than 47 mm.

Figure 1 shows an example of a tumble drum.



**6.3 Drum rotation equipment**, capable of ensuring that the drum attains full speed in one revolution, rotates at a constant speed of 25 r/min  $\pm$  1 r/min and stops within one revolution. The equipment shall be fitted with a revolution counter and with an automatic device for stopping the drum after a predetermined number of revolutions.

**6.4 Test sieves**, conforming to ISO 3310-1 or ISO 3310-2 and having square apertures of the following nominal sizes: 6,30 mm and 500  $\mu$ m.

**6.5 Weighing device**, capable of weighing the test sample and test portions and having a sensitivity of 1/1 000 or better.

## 7 Procedure

### 7.1 Number of determinations for the test

Carry out the test as many times as required by the procedure in Annex A.

### 7.2 Tumbling

Take, at random, one of the test portions prepared in 5.2, record its mass ( $m_0$ ) and place it in the tumble drum (6.2). Tightly fasten the door and rotate the drum at 25 r/min  $\pm$  1 r/min for a total of 200 revolutions. Stop the drum and keep the door fastened for at least 2 min before opening, to allow the dust to settle.

**DANGER — Tumbling can be noisy and care must be taken to protect the hearing of the operator.**

It is recommended that putty or modelling clay be used to seal the door, to prevent the loss of fines from the drum.

### 7.3 Sieving

Remove all the material carefully from the drum and hand sieve it on the 6,30 mm and 500  $\mu$ m sieves (6.4), in accordance with ISO 4701. Determine and record the mass of each fraction retained on the 6,30 mm ( $m_1$ ) and 500  $\mu$ m ( $m_2$ ) sieves to the nearest 0,1 g. Material lost during sieving shall be considered to be part of the  $-500 \mu$ m fraction.

NOTE Scalping sieves can be used to lessen the load on the critical sieves.

The difference between the initial mass of the test portion and the total mass of the fractions shall not exceed 1,0 %. If this difference exceeds 1,0 %, the test shall be rejected.

## 8 Expression of results

### 8.1 Calculation of the tumble index (TI) and abrasion index (AI)

The tumble index, TI, and the abrasion index, AI, expressed as percentages by mass, are calculated from the following formula:

$$TI = \frac{m_1}{m_0} \times 100$$

$$AI = \frac{m_0 - (m_1 + m_2)}{m_0} \times 100$$

where

- $m_0$  is the mass, in kilograms, of the test portion as weighed out and placed in the tumble drum;
- $m_1$  is the mass, in kilograms, of + 6,30 mm fraction of the tumbled test portion;
- $m_2$  is the mass, in kilograms, of – 6,30 mm + 500  $\mu\text{m}$  fraction of the tumbled test portion.

Record each result to one decimal place.

## 8.2 Repeatability and acceptance of test results

Follow the procedure in Annex A for each of the indices, by using the repeatability given in Table 1. The results shall be reported to one decimal place.

**Table 1 — Repeatability ( $r$ )**

<b>Tumble strength</b>	$r$ %, absolute
Tumble index, TI (+ 6,30 mm)	1,4
Abrasion index, AI (– 500 $\mu\text{m}$ )	0,8

## 9 Test report

The test report shall include the following information:

- a) a reference to this International Standard, i.e. ISO 3271:2007;
- b) all details necessary for the identification of the sample;
- c) the name and address of the test laboratory;
- d) the date of the test;
- e) the date of the test report;
- f) the signature of the person responsible for the test;
- g) details of any operation and any test conditions not specified in this International Standard or regarded as optional, as well as any incident which may have had an influence on the results;
- h) the tumble index, TI, and the abrasion index, AI;
- i) the type of sieve used.

## 10 Verification

Regular checking of the apparatus is essential to ensure test-result reliability. The frequency of checking is a matter for each laboratory to determine.

The conditions of the following items shall be checked:

- sieves;
- weighing device;
- tumble drum;
- drum rotation equipment.

It is recommended that internal reference material be prepared and used periodically to check test repeatability.

Appropriate records of verification activities shall be maintained.

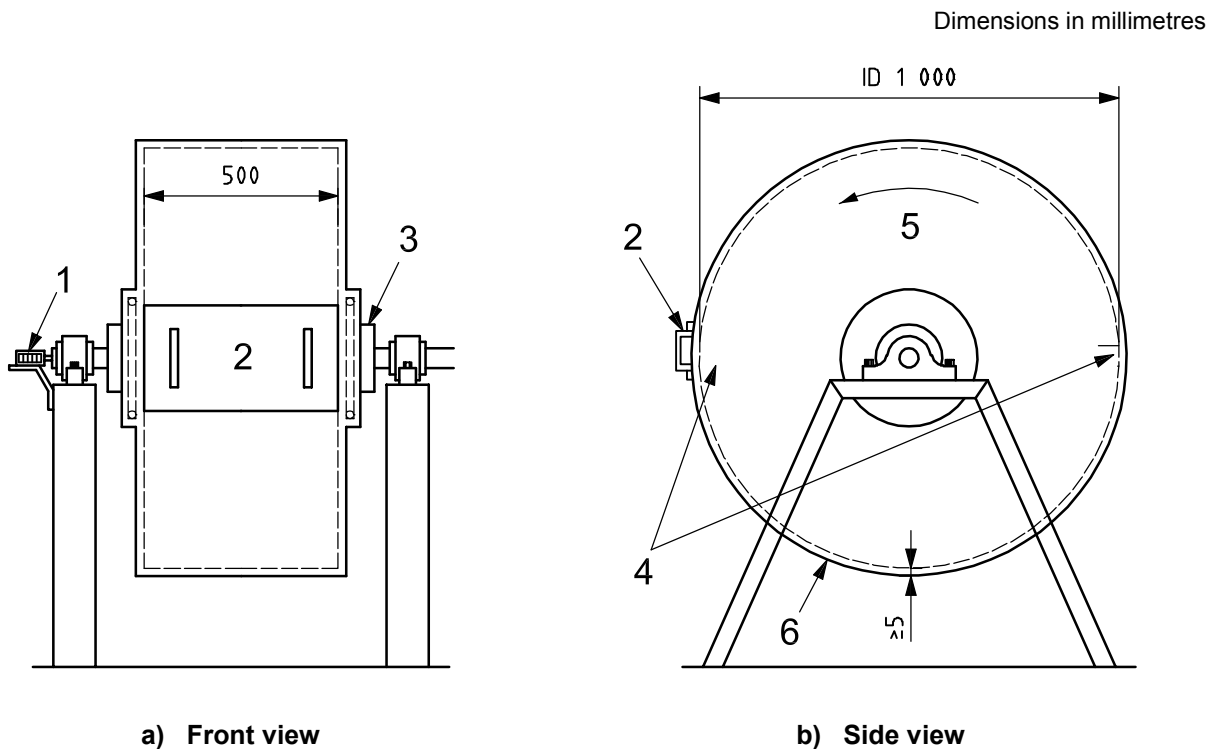

### Key

- 1 revolution counter
- 2 door with handle
- 3 stub axle (no through shaft)
- 4 two lifters (50 × 50 × 5)
- 5 direction of rotation
- 6 plate

ID Internal diameter

**Figure 1 — Example of test apparatus (schematic diagram)**

## Annex A (normative)

### Flowsheet of the procedure for the acceptance of test results

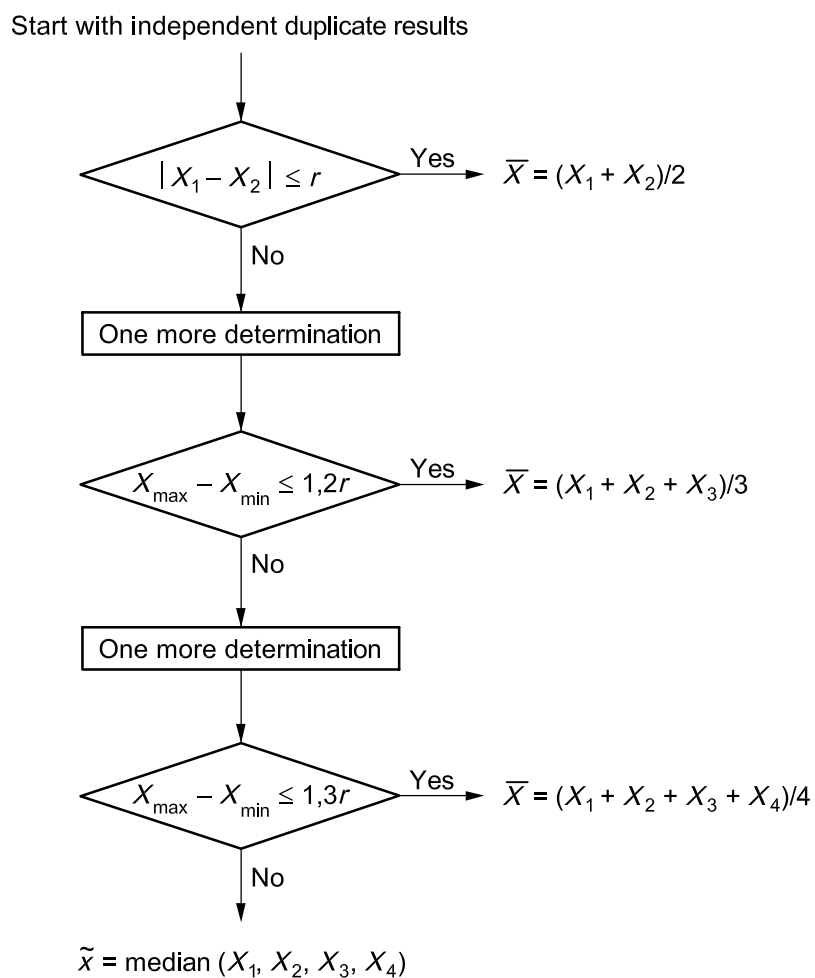

*r*: see Table 1

© 2011 International Organization for Standardization

---

---

**ICS 73.060.10**

Price based on 6 pages