

---

---

**Anodizing of aluminium and its alloys —  
Assessment of resistance of anodic  
oxidation coatings to cracking by  
deformation**

*Anodisation de l'aluminium et de ses alliages — Évaluation de la  
résistance des couches anodiques à la formation de criques par  
déformation*

**PDF disclaimer**

This PDF file may contain embedded typefaces. In accordance with Adobe's licensing policy, this file may be printed or viewed but shall not be edited unless the typefaces which are embedded are licensed to and installed on the computer performing the editing. In downloading this file, parties accept therein the responsibility of not infringing Adobe's licensing policy. The ISO Central Secretariat accepts no liability in this area.

Adobe is a trademark of Adobe Systems Incorporated.

Details of the software products used to create this PDF file can be found in the General Info relative to the file; the PDF-creation parameters were optimized for printing. Every care has been taken to ensure that the file is suitable for use by ISO member bodies. In the unlikely event that a problem relating to it is found, please inform the Central Secretariat at the address given below.



**COPYRIGHT PROTECTED DOCUMENT**

© ISO 2010

All rights reserved. Unless otherwise specified, no part of this publication may be reproduced or utilized in any form or by any means, electronic or mechanical, including photocopying and microfilm, without permission in writing from either ISO at the address below or ISO's member body in the country of the requester.

ISO copyright office  
Case postale 56 • CH-1211 Geneva 20  
Tel. + 41 22 749 01 11  
Fax + 41 22 749 09 47  
E-mail [copyright@iso.org](mailto:copyright@iso.org)  
Web [www.iso.org](http://www.iso.org)

Published in Switzerland

## Foreword

ISO (the International Organization for Standardization) is a worldwide federation of national standards bodies (ISO member bodies). The work of preparing International Standards is normally carried out through ISO technical committees. Each member body interested in a subject for which a technical committee has been established has the right to be represented on that committee. International organizations, governmental and non-governmental, in liaison with ISO, also take part in the work. ISO collaborates closely with the International Electrotechnical Commission (IEC) on all matters of electrotechnical standardization.

International Standards are drafted in accordance with the rules given in the ISO/IEC Directives, Part 2.

The main task of technical committees is to prepare International Standards. Draft International Standards adopted by the technical committees are circulated to the member bodies for voting. Publication as an International Standard requires approval by at least 75 % of the member bodies casting a vote.

Attention is drawn to the possibility that some of the elements of this document may be the subject of patent rights. ISO shall not be held responsible for identifying any or all such patent rights.

ISO 3211 was prepared by Technical Committee ISO/TC 79, *Light metals and their alloys*, Subcommittee SC 2, *Organic and anodic oxidation coatings on aluminium*.

This third edition cancels and replaces the second edition (ISO 3211:1977), which has been technically revised.



# Anodizing of aluminium and its alloys — Assessment of resistance of anodic oxidation coatings to cracking by deformation

## 1 Scope

This International Standard specifies an empirical method for assessing the resistance of anodic oxidation coatings to cracking by deformation.

The method is applicable particularly to sheet material with anodic oxidation coatings of thickness less than 5 µm, and is useful for development purposes.

NOTE If the test piece is thick, even more than 5 µm of coating can be measured (see Clause 6).

## 2 Principle

A test piece is bent along a spiral, graduated with a radius of curvature index, using a simple instrument. The radius of curvature corresponding to the region where the first cracks in the oxide layer appear is determined and the percentage elongation of the test piece corresponding to this radius is calculated.

## 3 Apparatus

**3.1 Measuring instrument**, as shown in Figure 1, which includes the following elements.

**3.1.1 Steel former**, mounted on a suitable base, in the shape of a spiral, graduated in deformation indexes,  $E$ , from 1 to 18. These indexes,  $E$ , correspond to radii of curvature,  $R$ , as shown in Table 1, and are derived from Equation (1):

$$R = 21 - E \quad (1)$$

where

$R$  is the radius of curvature, in centimetres;

$E$  is the deformation index corresponding to the region where the first cracks appear.

**3.1.2 Two screws**, for clamping the ends of the test piece.

Table 1 — Relationship between radius of curvature  $R$  and deformation index  $E$ 

Deformation index $E$	Radius of curvature $R$ cm	Deformation index $E$	Radius of curvature $R$ cm
1	20	10	11
2	19	11	10
3	18	12	9
4	17	13	8
5	16	14	7
6	15	15	6
7	14	16	5
8	13	17	4
9	12	18	3

## 4 Procedure

### 4.1 Test piece

Cut a strip of anodized aluminium having approximately the following dimensions:

- length: 25 cm;
- width: 2 cm;
- maximum thickness: 0,5 cm.

### 4.2 Determination

Clamp one end of the test piece with the clamping screw 3 with the significant surface outwards.

Bend the test piece progressively over the spiral, in such a way that the test piece remains in contact with the spiral, and clamp the other end with the second screw 5.

Beginning from clamping screw 3, examine the anodic oxidation coating and mark the region where the first cracks appear.

If the cracks are difficult to detect, they can be rendered visible using the procedure described in ISO 2085 by removing the bent test piece and immersing it in copper sulfate solution for 5 min, then rinsing and drying it. The test piece is then replaced on the apparatus and the deformation index corresponding to the region where the first cracks appear is marked.

## 5 Expression of results

Express the elongation,  $A$ , of the anodized metal as a percentage using Equation (2):

$$A = \frac{100d}{2R + d} \quad (2)$$

where

$d$  is the thickness, in centimetres, of the test piece;

$R$  is the radius of curvature, in centimetres, given by Equation (1).

## 6 Test report

The test report shall include at least the following information:

- a) a reference to this International Standard;
- b) the type and identification of the product tested;
- c) the result of the test (see Clause 5);
- d) the thickness of the test piece, the anodic coating thickness and the index,  $E$ , in the case of a thick test piece with an anodic coating greater than 5  $\mu\text{m}$ ;
- e) anything unusual noticed during the determination;
- f) any operations not included in the procedure described in this International Standard, or considered to be optional;
- g) the date of the test.

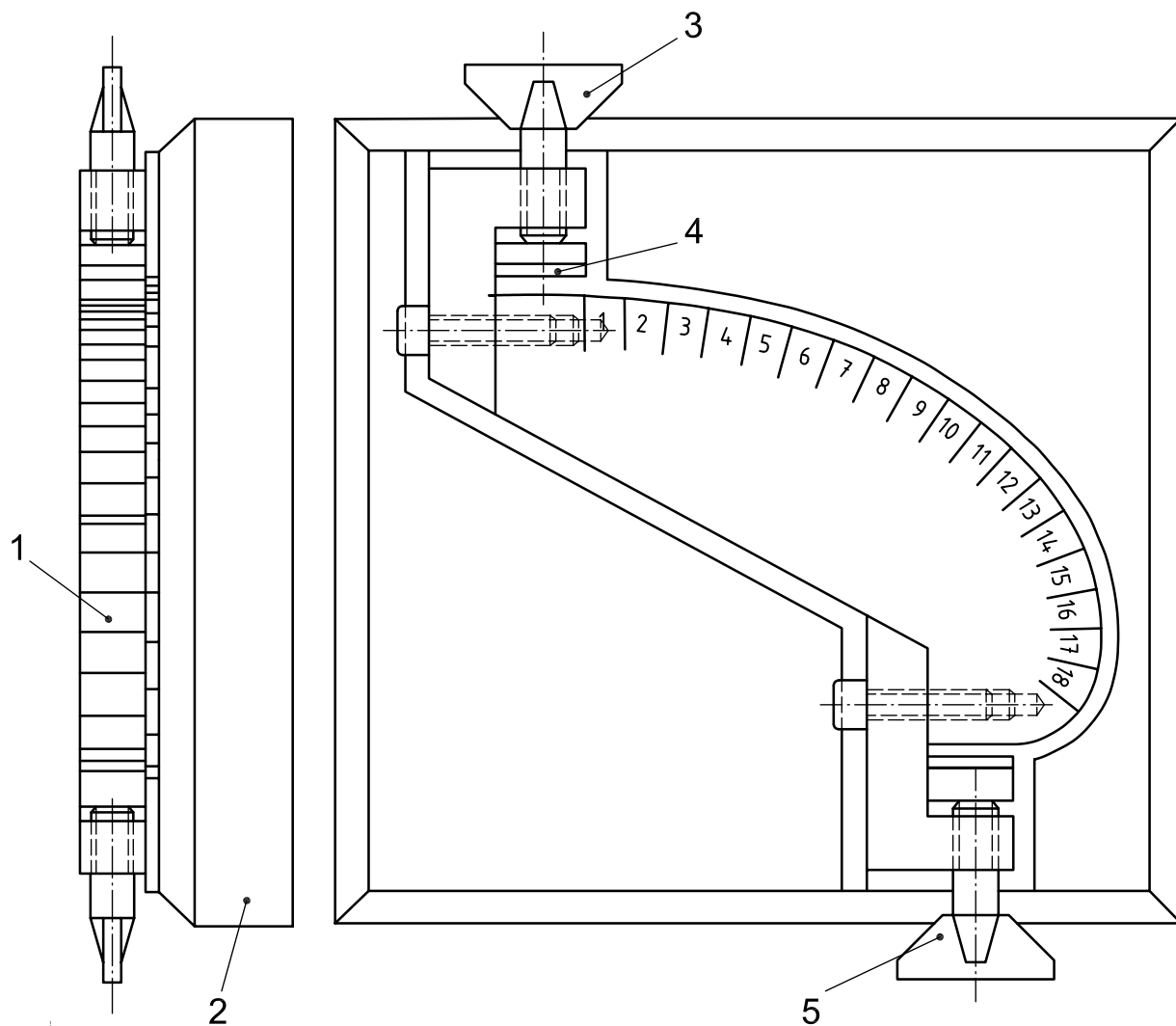

**Key**

- |   |                           |   |                |
|---|---------------------------|---|----------------|
| 1 | steel spiral              | 4 | rubber pad     |
| 2 | wooden base               | 5 | clamping screw |
| 3 | clamping screw, removable |   |                |

**Figure 1 — Deformation index measuring instrument (scale 1: 1,7)**



## Bibliography

- [1] ISO 2085, *Anodizing of aluminium and its alloys — Check for continuity of thin anodic oxidation coatings — Copper sulfate test*

.....

---

---

**ICS 25.220.20**

Price based on 5 pages