**Aerospace — Screws, pan head, internal
offset cruciform ribbed or unribbed drive,
threaded to head, MJ threads, metallic
material, coated or uncoated, strength
classes less than or equal to 1 100 MPa —
Dimensions**

Aéronautique et espace — Vis à tête cylindrique, à empreinte cruciforme déportée, avec ou sans saillies antidérapantes, filetées jusqu'à proximité de la tête, à filetage MJ, en matériau métallique, revêtues ou non revêtues, des classes de résistance inférieures ou égales à 1 100 MPa — Dimensions



Foreword

ISO (the International Organization for Standardization) is a worldwide federation of national standards bodies (ISO member bodies). The work of preparing International Standards is normally carried out through ISO technical committees. Each member body interested in a subject for which a technical committee has been established has the right to be represented on that committee. International organizations, governmental and non-governmental, in liaison with ISO, also take part in the work. ISO collaborates closely with the International Electrotechnical Commission (IEC) on all matters of electrotechnical standardization.

Draft International Standards adopted by the technical committees are circulated to the member bodies for voting. Publication as an International Standard requires approval by at least 75 % of the member bodies casting a vote.

International Standard ISO 3202 was prepared by Technical Committee ISO/TC 20, *Aircraft and space vehicles*, Subcommittee SC 4, *Aerospace fastener systems*.

This second edition cancels and replaces the first edition (ISO 3202:1991), of which it constitutes a technical revision.

© ISO 1997

All rights reserved. Unless otherwise specified, no part of this publication may be reproduced or utilized in any form or by any means, electronic or mechanical, including photocopying and microfilm, without permission in writing from the publisher.

International Organization for Standardization
Case postale 56 • CH-1211 Genève 20 • Switzerland
Internet central@iso.ch
X.400 c=ch; a=400net; p=iso; o=isocs, s=central

Printed in Switzerland

Aerospace — Screws, pan head, internal offset cruciform ribbed or unribbed drive, threaded to head, MJ threads, metallic material, coated or uncoated, strength classes less than or equal to 1 100 MPa — Dimensions

1 Scope

This International Standard specifies the dimensions of threaded to head pan head screws, with internal offset cruciform ribbed or unribbed drive, MJ threads, in metallic material, coated or uncoated, with strength classes less than or equal to 1 100 MPa.

This International Standard is applicable for the compilation of aerospace product standards.

2 Normative references

The following standards contain provisions which, through reference in this text, constitute provisions of this International Standard. At the time of publication, the editions indicated were valid. All standards are subject to revision, and parties to agreements based on this International Standard are encouraged to investigate the possibility of applying the most recent editions of the standards indicated below. Members of IEC and ISO maintain registers of currently valid International Standards.

ISO 3353:1992, *Aerospace — Rolled threads for bolts — Lead and runout requirements.*

ISO 5855-2:1988, *Aerospace — MJ threads — Part 2: Limit dimensions for bolts and nuts.*

ISO 7913:1994, *Aerospace — Bolts and screws, metric — Tolerances of form and position.*

ISO 14275:—¹⁾, *Aerospace — Drives, internal, offset cruciform, ribbed — Metric series.*

ISO 14276:—¹⁾, *Aerospace — Drives, internal, offset cruciform — Metric series.*

3 Configuration and dimensions

See figure 1 and table 1. Dimensions and tolerances are expressed in millimetres. They are applicable after any surface coating, but before the application of any lubricant.

Tolerances of form and position are specified in ISO 7913.

1) To be published.

Break sharp edges 0,1 to 0,4

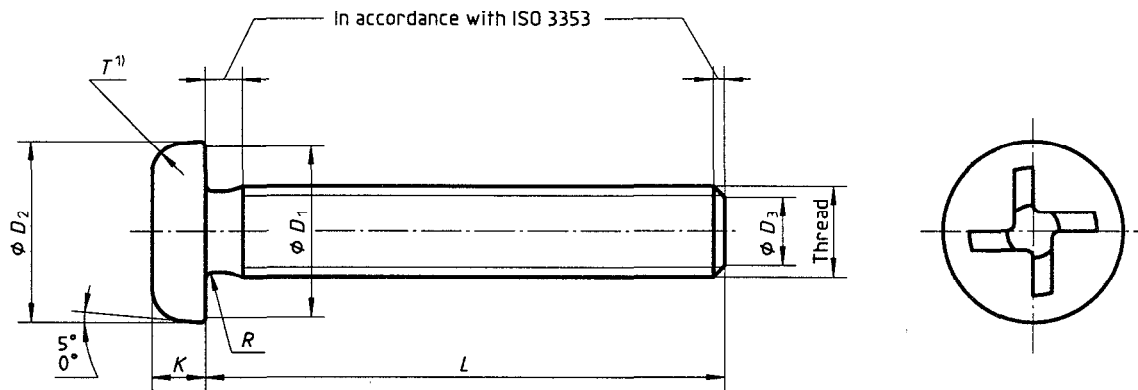

1) Shape optional.

Figure 1

Table 1

Diameter code	Thread ¹⁾	D ₁ min	D ₂ ⁰ / _{-0,3}	D ₃		K		L ²⁾ ±0,3	R		T		Drive code ³⁾
				nom	tol	nom.	tol		nom	tol	max	min	
016	MJ1,6×0,35-4h6h	1,9	3,2	1,1	⁰ / _{-0,5}	1	⁰ / _{-0,2}	4 to 22	0,3	⁰ / _{-0,2}	0,7	0,2	R1,6
020	MJ2×0,4-4h6h	2,7	4	1,4		1,2		4 to 28			0,8		R2
025	MJ2,5×0,45-4h6h	3,7	5	1,9		1,5		4 to 36			1,0	R2,5	
030	MJ3×0,5-4h6h	4,7	6	2,3		1,8		4 to 42	1,2		0,3	R3	
035	MJ3,5×0,6-4h6h	5,7	7	2,7		2,1		6 to 50	1,4		0,4	R3,5	
040	MJ4×0,7-4h6h	6,7	8	3		2,4		6 to 56	1,6		0,4	R4	
050	MJ5×0,8-4h6h	8,7	10	3,4		3		8 to 70	2,0		0,5	R5	
060	MJ6×1-4h6h	10,7	12	4,2		3,6		10 to 84	2,4		0,6	R6	
070	MJ7×1-4h6h	12,7	14	5,2		4,2		10 to 98	2,8		0,7		
080	MJ8×1-4h6h	14,7	16	6,2		±0,5		4,8	⁰ / _{-0,3}		10 to 112	0,7	⁰ / _{-0,2}
100	MJ10×1,25-4h6h	18,7	20	7,9	6		14 to 140	4		1	R10		
120	MJ12×1,25-4h6h	22,7	24	9,8	7,2		16 to 168	4,8		1,2	R12		

1) In accordance with ISO 5855-2

2) Increments:

2 for L ≤ 100

4 for L > 100

If greater lengths are required, they shall be chosen using these increments.

3) In accordance with ISO 14276 for codes R1,6 to R2,5 In accordance with ISO 14275 or ISO 14276 for codes ≥ R3

ICS 49.030.20

Descriptors: aircraft industry, fasteners, threaded fasteners, MJ threads, screws, pan head screws, cross recessed screws, offset-cross recessed screws, form specifications, dimensions, dimensional tolerances.

Price based on 2 pages
