**Earth-moving machinery —
Laboratory evaluations of protective
structures — Specifications for
deflection-limiting volume**

*Engins de terrassement — Étude en laboratoire des structures de
protection — Spécifications pour le volume limite de déformation*



Reference number
ISO 3164:2013(E)

© ISO 2013



COPYRIGHT PROTECTED DOCUMENT

© ISO 2013

All rights reserved. Unless otherwise specified, no part of this publication may be reproduced or utilized otherwise in any form or by any means, electronic or mechanical, including photocopying, or posting on the internet or an intranet, without prior written permission. Permission can be requested from either ISO at the address below or ISO's member body in the country of the requester.

ISO copyright office
Case postale 56 • CH-1211 Geneva 20
Tel. + 41 22 749 01 11
Fax + 41 22 749 09 47
E-mail copyright@iso.org
Web www.iso.org

Published in Switzerland

Contents

Page

Foreword	iv
1 Scope	1
2 Normative references	1
3 Terms and definitions	1
4 DLV dimensions, use and accuracy	2
5 Location of DLV	2

Foreword

ISO (the International Organization for Standardization) is a worldwide federation of national standards bodies (ISO member bodies). The work of preparing International Standards is normally carried out through ISO technical committees. Each member body interested in a subject for which a technical committee has been established has the right to be represented on that committee. International organizations, governmental and non-governmental, in liaison with ISO, also take part in the work. ISO collaborates closely with the International Electrotechnical Commission (IEC) on all matters of electrotechnical standardization.

International Standards are drafted in accordance with the rules given in the ISO/IEC Directives, Part 2.

The main task of technical committees is to prepare International Standards. Draft International Standards adopted by the technical committees are circulated to the member bodies for voting. Publication as an International Standard requires approval by at least 75 % of the member bodies casting a vote.

Attention is drawn to the possibility that some of the elements of this document may be the subject of patent rights. ISO shall not be held responsible for identifying any or all such patent rights.

ISO 3164 was prepared by Technical Committee ISO/TC 127, *Earth-moving machinery*, Subcommittee SC 2, *Safety, ergonomics and general requirements*.

This sixth edition cancels and replaces the fifth edition (ISO 3164:1995), which has been technically revised.

Earth-moving machinery — Laboratory evaluations of protective structures — Specifications for deflection-limiting volume

1 Scope

This International Standard specifies the deflection limiting volume (DLV) to be used when performing laboratory evaluations of structures which provide protection to operators of earth-moving machinery as defined in ISO 6165.

2 Normative references

The following documents, in whole or in part, are normatively referenced in this document and are indispensable for its application. For dated references, only the edition cited applies. For undated references, the latest edition of the referenced document (including any amendments) applies.

ISO 3411:2007, *Earth-moving machinery — Physical dimensions of operators and minimum operator space envelope*

ISO 5353:1995, *Earth-moving machinery, and tractors and machinery for agriculture and forestry — Seat index point*

ISO 6165, *Earth-moving machinery — Basic types — Identification and terms and definitions*

3 Terms and definitions

For the purposes of this document, the following terms and definitions apply.

3.1 deflection-limiting volume

DLV

approximation of a large seated operator as defined in ISO 3411

3.1.1

orthogonal DLV

DLV (3.1) that is an orthogonal approximation of an operator

Note 1 to entry: See [Figure 1](#).

3.1.2

rounded DLV

orthogonal DLV (3.1.1) with corners rounded to approximate the curvature of the operator (e.g. head, shoulders)

Note 1 to entry: See [Figure 2](#).

3.1.3

orthogonal top head plane

270 mm by 330 mm rectangular horizontal surface used with the *rounded DLV* (3.1.2) to replicate the top horizontal surface of the *orthogonal DLV* (3.1.1)

Note 1 to entry: See [Figure 3](#).

Note 2 to entry: This top head plane is to be used with the rounded DLV when testing a FOPS (falling-object protective structure).

3.2
seat index point
SIP

point on the central vertical plane of the seat as determined by ISO 5353

3.3
locating axis
LA

horizontal axis for positioning the *DLV* (3.1) with respect to the *SIP* (3.2)

4 DLV dimensions, use and accuracy

4.1 The dimensions of the orthogonal DLV shall be as shown in [Figure 1](#) and the dimensions of the rounded DLV as shown in [Figure 2](#).

4.2 The dimension from the SIP to the rear boundary of the DLV assumes that the seat has 150 mm fore-aft adjustment. The 210 mm dimension shall be reduced from 210 mm to 135 mm if the seat does not have any fore-aft adjustment. If the fore-aft seat adjustment is less than 150 mm, the 210 mm dimension shall be reduced by one half of the difference between 150 mm and the actual fore-aft seat adjustment.

4.3 ROPS (roll-over protective structure) and TOPS (tip-over protective structure) testing shall use either the rounded or the orthogonal DLV. FOPS (falling-object protective structure) testing shall use the orthogonal DLV or the rounded DLV with an added orthogonal top head plane.

4.4 During lateral loading for TOPS and ROPS testing, it is permissible for the upper portion of the DLV to be rotated laterally about the SIP up to 15° (see [Table 1](#)). During longitudinal loading for TOPS and ROPS testing, it is permissible for the upper portion of the DLV to be rotated forwards about the LA up to 15°. See the examples given in [Figure 4](#). The portion below the SIP of the DLV does not rotate. If there is interference with any machine component, rotation of the DLV shall be limited to the angle at which the interference occurs.

Table 1 — Summary of allowed DLV rotation during ROPS/TOPS testing

ROPS/TOPS loading direction	Degrees	DLV rotation direction
Lateral loading	15	Lateral
Longitudinal loading	15	Longitudinal

The rounded DLV better represents the shape of the operator’s head when the DLV is rotated in the longitudinal and lateral directions.

4.5 All linear dimensions of the DLV shown in [Figures 1](#) and [2](#) shall have a tolerance of ±5 mm. The accuracy of locating the DLV with respect to the SIP shall be ±13 mm, horizontally and vertically. The accuracy of the rotation shall be ±1°.

5 Location of DLV

5.1 The DLV shall be located using the SIP, as defined in ISO 5353, as the reference point (see [Figures 1](#) and [2](#)).

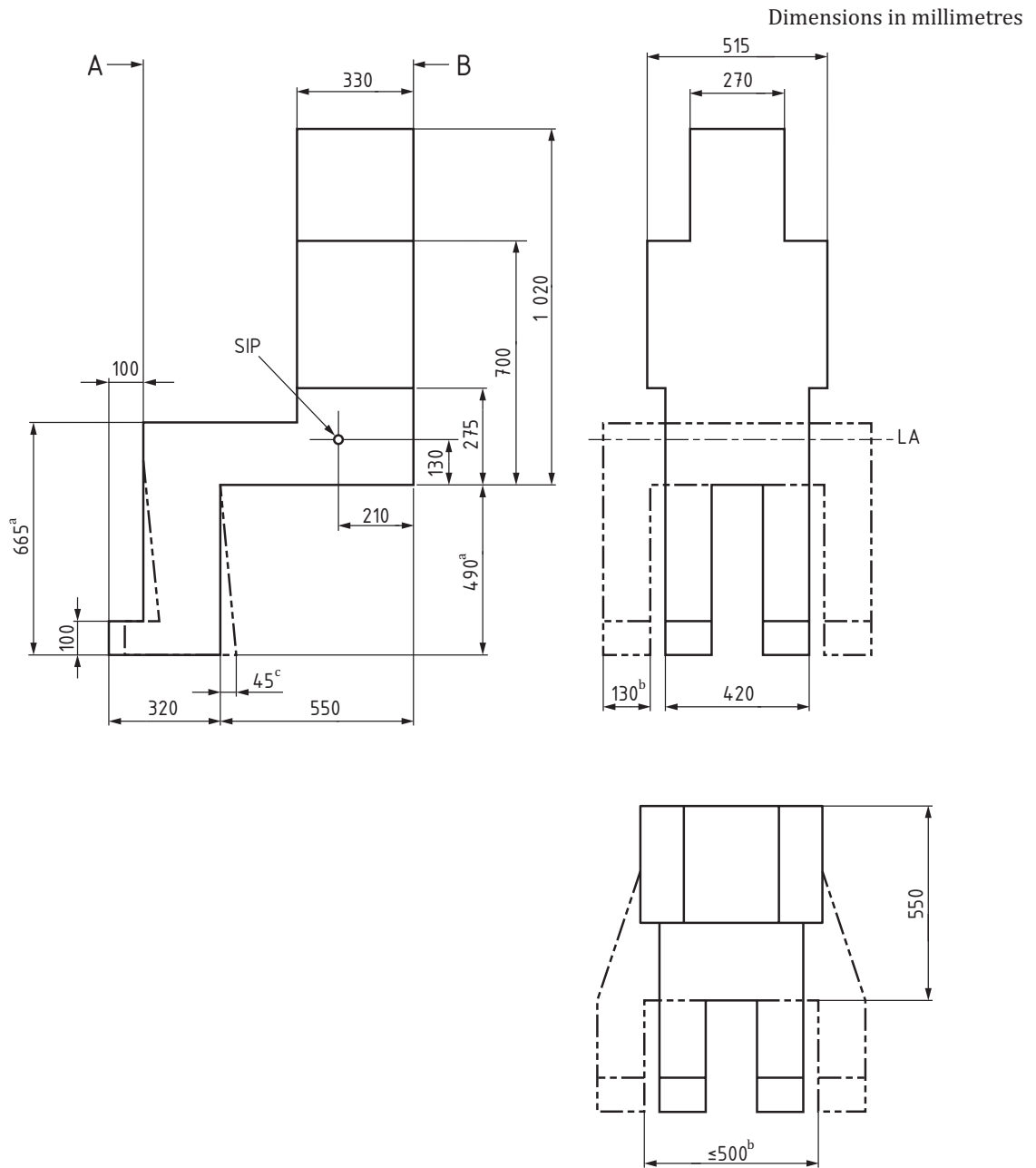

Key

A front boundary plane

B rear boundary plane

LA locating axis

SIP seat index point

a May be reduced to avoid interference with floor plates.

b Machine parts or controls can require additional separation of the feet and legs of the DLV.

c Feet may move 45 mm rearwards.

Figure 1 — Orthogonal DLV dimensions

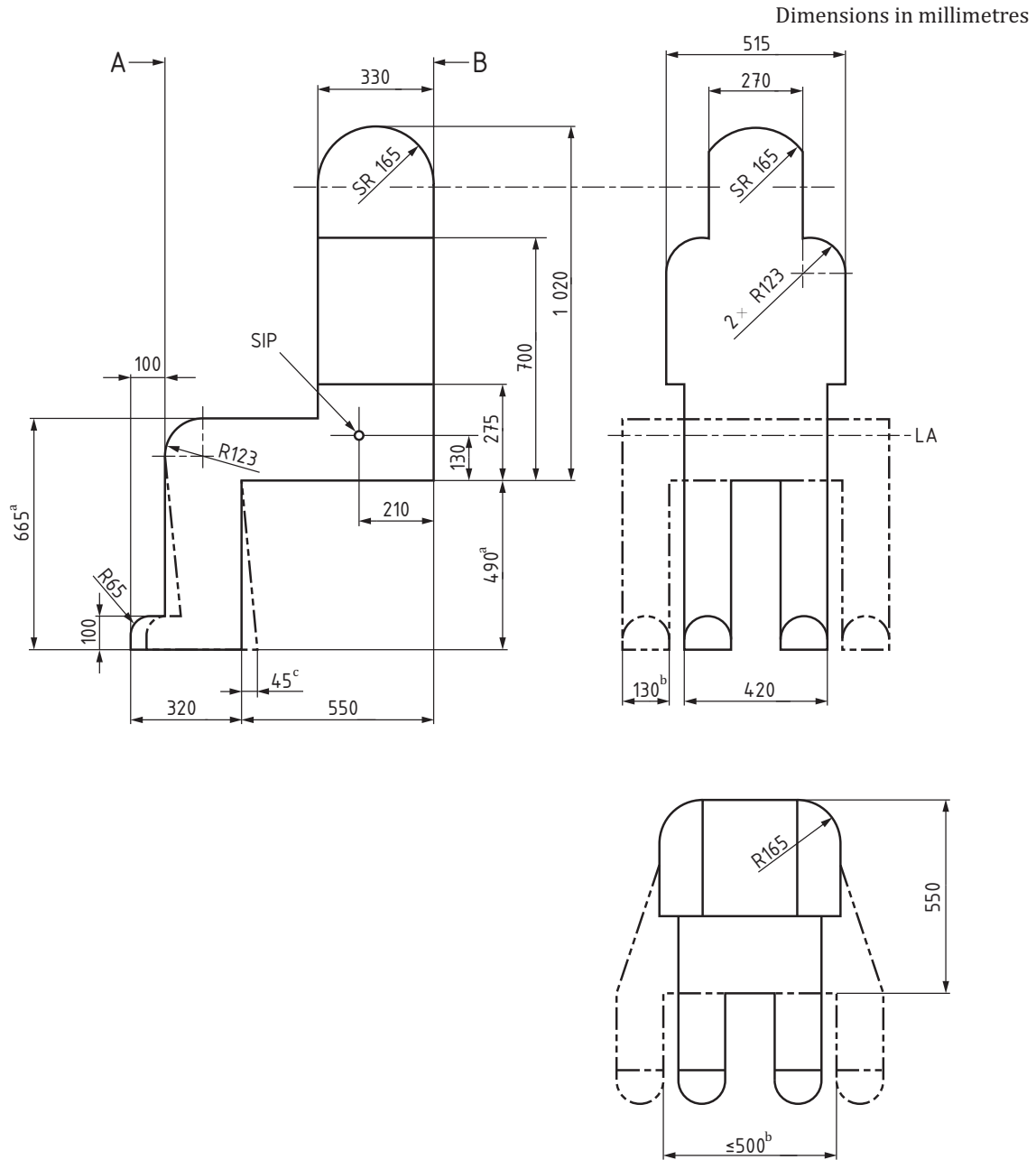

Key

A front boundary plane

B rear boundary plane

LA locating axis

SIP seat index point

a May be reduced to avoid interference with floor plates.

b Machine parts or controls can require additional separation of the feet and legs of the DLV.

c Feet may move 45 mm rearwards.

Figure 2 — Rounded DLV dimensions

5.2 For machines which have multiple seat locations and therefore multiple SIPs (see ISO 5353:1995, 5.3.3), the SIP used by the operator to move the machine in the travel mode shall be used.

5.3 The DLV shall be positioned so that the locating axis (LA) shown in [Figure 1](#) passes through the SIP location as determined in [5.2](#). The DLV shall be centred transversely in the seat location with its principal axes horizontal and vertical (axes X' and Z' as defined in ISO 5353:1995, [Figure 2](#)).

5.4 The location of the LA of the DLV shall remain coincidental with the SIP even though that line can move during any or all of the laboratory loadings.

NOTE Machine controls and their components normally positioned in the DLV are not considered to violate the DLV.

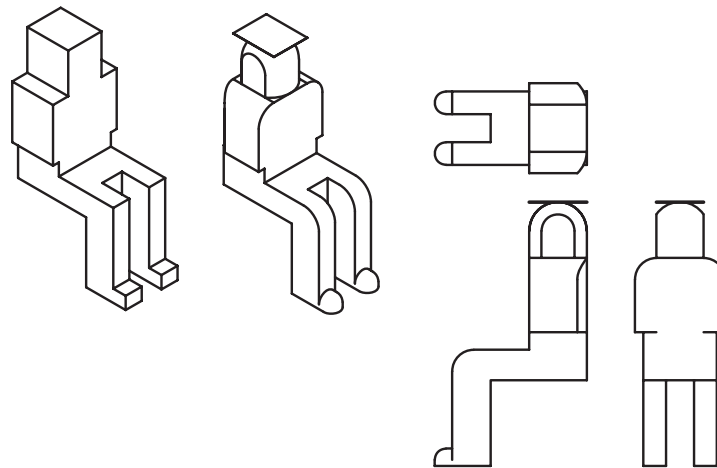
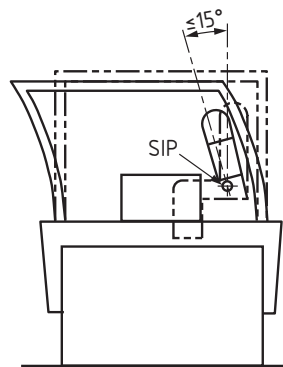
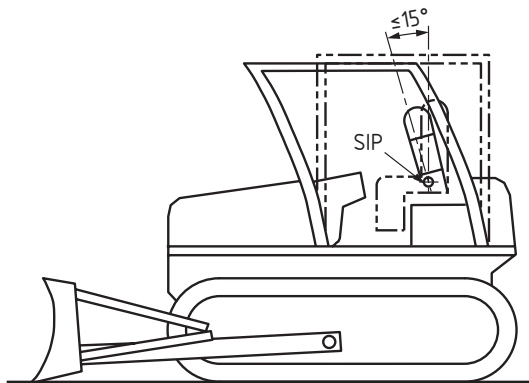

Figure 3 — Perspective and orthogonal top head plane for use with rounded DLV for FOPS testing



a) Lateral load on roller with sideways-mounted seat



b) Longitudinal load on tractor-dozer

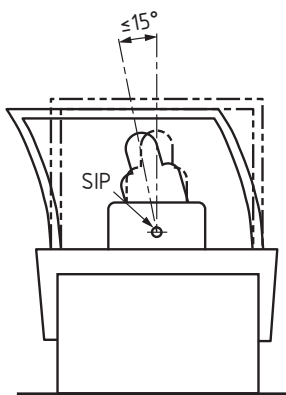

c) Lateral load on roller with forward-mounted seat

Key

SIP seat index point

Figure 4 — Example rotation of DLV

.....

ICS 53.100

Price based on 6 pages