

INTERNATIONAL
STANDARD

ISO
3157

Second edition
1991-11-15

**Radioluminescence for time measurement
instruments — Specifications**

Radioluminescence pour les instruments horaires — Spécifications



Reference number
ISO 3157:1991(E)

Foreword

ISO (the International Organization for Standardization) is a worldwide federation of national standards bodies (ISO member bodies). The work of preparing International Standards is normally carried out through ISO technical committees. Each member body interested in a subject for which a technical committee has been established has the right to be represented on that committee. International organizations, governmental and non-governmental, in liaison with ISO, also take part in the work. ISO collaborates closely with the International Electrotechnical Commission (IEC) on all matters of electrotechnical standardization.

Draft International Standards adopted by the technical committees are circulated to the member bodies for voting. Publication as an International Standard requires approval by at least 75 % of the member bodies casting a vote.

International Standard ISO 3157 was prepared by Technical Committee ISO/TC 114, *Horology*, Sub-Committee SC 5, *Luminescence*.

This second edition cancels and replaces the first edition (ISO 3157:1975), which has been technically revised.

Annex A of this International Standard is for information only.

© ISO 1991

All rights reserved. No part of this publication may be reproduced or utilized in any form or by any means, electronic or mechanical, including photocopying and microfilm, without permission in writing from the publisher.

International Organization for Standardization
Case Postale 56 • CH-1211 Genève 20 • Switzerland

Printed in Switzerland

Radioluminescence for time measurement instruments — Specifications

1 Scope

This International Standard specifies requirements for the optical, mechanical and radioactive characteristics of the radioluminescent deposits fixed on time measurement instruments, together with the test methods relating to them.

Clause 3 applies to all time measurement instruments which include components (hands, dials, bezels, etc.) bearing radioluminescent deposits.

Clause 4 applies to the deposits themselves, whether they are fixed on the time measurement instruments in question, or on special supports.

2 Definitions

For the purposes of this International Standard, the following definitions apply.

2.1 radioluminescence: Luminescence caused by the radiation of a radionuclide within certain crystalline powders (ZnS, Zn₂SiO₄, etc.).

2.2 radioluminescent deposit: A radioluminescent substance in powder form mixed with a binder and fixed on a support.

2.3 special time measurement instruments: Instruments designed for uses which require considerable luminosity. Because of this, the quantity of radioactive substance used is greater.

NOTE 1 In this International Standard, the terms in italics have the same meaning as in current international documents. It is specified that the *luminous intensities* are, until further notice, defined on the basis of $V(\lambda)$, the photopic luminous efficiency function defining the mean eye for photometry. Certain terms must, however, be specially defined.

3 Specifications and test methods for time measurement instruments

3.1 General

This clause gives specifications for time measurement instruments bearing radioluminescent deposits, as well as the test methods which shall be used.

3.2 Legibility

3.2.1 For watches using radioluminescent substances, the following quality criteria apply.

- a) At least four hour markings shall be used. It is permissible to use only three, however, when the instrument includes an aperture.
- b) The 12 shall be differentiated from the other markings.
- c) The hour-hand shall be differentiated from the minute-hand.
- d) If only four markings are used, the total *luminous intensity*, i.e. that of the whole (hands + markings) shall be at least 25 ncd. However, in the case of three markings, permitted above, this lower limit is reduced to 22 ncd.
- e) If more than four markings are used, the above threshold is increased by 3 ncd per additional marking.
- f) The pair of hands, taken in isolation, shall have a *luminous intensity* of 10 ncd or more.

3.2.2 For time measurement instruments not worn on the person, the minimum values of the *luminous intensities* above are doubled; points a), b) and c) of 3.2.1 also remain valid.

These specifications apply within the framework of present techniques, but they do not constitute a limitation on the development of new techniques based, for example, on the use of non-luminescent markings on dials whose whole surface is luminescent.

3.3 Nature of the radionuclides used

3.3.1 Only the use of the following radionuclides is authorized:

Tritium	(³ H)	For marking: T
Promethium	(¹⁴⁷ Pm)	For marking: Pm

3.3.2 The use of different radionuclides on the same time measurement instrument is prohibited.

NOTE 2 Attention is drawn to the fact that certain national regulations may prohibit or limit the use of one of the radionuclides listed in 3.3.1.

3.4 Total radioactivity of the instruments

Tables 1 to 3 give, for each category of instrument and type of radionuclide, the maximum values authorized for the mean radioactivity of the instruments of a lot, according to document No. 23 of the IAEA Safety Series, and the radioactivity of an instrument considered individually.

Table 1 — Time measurement instruments: Worn

Radio-nuclide	Maximum permitted mean activity of a lot (per instrument)	Maximum permitted activity of an isolated instrument
³ H	185 MBq (5 mCi)	277 MBq (7,5 mCi)
¹⁴⁷ Pm	3,7 MBq (0,1 mCi)	5,5 MBq (0,15 mCi)

Table 2 — Time measurement instruments: Not worn or carried on the person

Radio-nuclide	Maximum permitted mean activity of a lot (per instrument)	Maximum permitted activity of an isolated instrument
³ H	277 MBq (7,5 mCi)	370 MBq (10 mCi)
¹⁴⁷ Pm	5,5 MBq (0,15 mCi)	7,4 MBq (0,2 mCi)

Table 3 — Special time measurement instruments

Radio-nuclide	Maximum permitted activity of an isolated instrument
³ H	925 MBq (25 mCi)
¹⁴⁷ Pm	18,5 MBq (0,5 mCi)

3.5 Protection against radioactivity

The "envelope" of the time measurement instrument (case, glass and protective varnish) shall be so constituted that the user is protected against any direct contact with the components treated with radioluminescent material, and that the low-energy β -radiations are sufficiently absorbed.

In any case, any deposit of radioluminescent material shall be protected by a thickness of transparent non-radioactive material equal to 50 mg/cm² or more.

The mechanical strength of this protection shall be sufficient to bear the stresses encountered under normal conditions of use and, as far as is reasonably practicable, during possible accidents.

3.6 Checking the radioactivity

The radioactivity may be checked, in relation to the requirements specified in 3.4, on the time measurement instrument fitted with its normal protection (glass). A method based on photometric measurement is authorized. If the measurement of the *Bremsstrahlung* is used, account shall be taken of the attenuation due to the glass and to the deposit itself. The thicknesses of the glass and the deposit are either measured or estimated by convention at 50 mg/cm² each. This is without prejudice to the requirements specified in 3.5.

When uncertainty resulting from the above-mentioned methods of checking makes it impossible to guarantee that the requirements specified in 3.4 are complied with, a destructive method shall be used to measure the activity. Such destructive methods shall consist in isolating the radionuclide from the other constituents of the luminescent substance, or from the deposit, and converting it into a form suitable for as accurate a measurement as possible to be made.

NOTE 3 For example, for tritiated substances, a suitable method consists in destruction of the luminescent deposit by combustion, collection of the liberated water and measurement of its activity with a liquid scintillator.

3.7 Marking

The marking specified below is obligatory only for special time measurement instruments. It is intended for the information of the horologist as well as the user.

It shall be effected, legibly and indelibly, on the dial of the instrument.

It shall comprise one of the two following indications:

- T 25** for deposits activated by tritium;
- Pm 0,5** for deposits activated by promethium.

These indications give the value, in millicuries, of the maximum authorized radioactivity.

For the other time measurement instruments, the marking can be made on the dial by the letters T or Pm.

3.8 Checking the marking

The marking shall be checked by visual inspection.

4 Specifications and test methods for radioluminescent deposits

4.1 General

This clause gives specifications for the radioluminescent deposits, as well as the test methods which shall be used.

The specifications relating to the deposits can be checked, unless special restrictions are indicated,

- a) on the finished instruments,
- b) on the dials (see clause 1 and 4.6), or
- c) on a sample placed on a standard support made of stainless steel having a *reflectivity* between 0,2 and 0,3, comprising a circular coupelle containing a circular cup with a surface area of 1 cm², intended to hold 50 mg of powder (see figure 1);
- d) on standard hands (see clause 1 and 4.6);
- e) on the rectangular support defined for the checking of the colours (see 4.2.2).

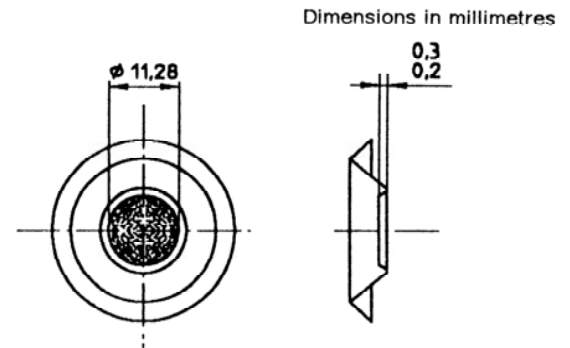

Figure 1 — Detail of a standard support for radioluminescent material

4.2 Colours

4.2.1 Standardized colours

The standardized colours are the following:

- C1 — white
- C3 — yellow
- C5 — greenish yellow
- C7 — green
- C9 — blue/green

This list is not restrictive and, on agreement between the manufacturer and the user, other colours may be used.

4.2.2 Checking the colours

The colours of the deposits shall be checked by visual examination, in daylight, without sun, on samples as defined in 4.1 c).

The colours shall be compared with those of reference standards consisting of 50 mg of non-activated luminescent powder deposited on a surface of 1 cm² at one end of a standard support of the design shown in figure 2, made of stainless steel having a *reflectivity* between 0,2 and 0,3. The reference standards shall be stored in the dark.

NOTE 4 The standards may be supplied on request by the Secretariat of ISO/TC 114, Bureau des normes de l'industrie horlogère suisse, Crêt-Taconnet 32, CH-2002 Neuchâtel.

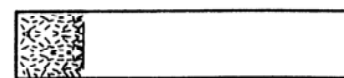

Figure 2 — Standard support for colour deposits

4.5 Adhesion

4.5.1 Procedure for dials and rigid components

The dials and rigid components shall be subjected to sinusoidal vibrations communicating an acceleration of greater than 20 m/s^2 (peak value), at a selected frequency between 25 Hz and 100 Hz, for a period of time such that the frequency multiplied by the time, expressed in seconds, is equal to 90 000.

4.5.2 Procedure for hands

4.5.2.1 Hands with a length of 15 mm or less shall be bent round a cylinder with a radius of 12,5 mm.

4.5.2.2 Hands with a length of over 15 mm shall be bent round a cylinder with a radius equal to the length of the hand, with a tolerance of ± 1 mm.

4.5.2.3 If, in the case of special designs, it is not possible to bend the hands round a cylinder, they shall be subjected to the vibration test specified for rigid components (see 4.5.1).

4.5.3 Estimation of the adhesion

Following these tests, examine the dials and hands as well as their immediate surroundings. The presence of alterations such as splits and cracks or of perceptible debris shall be considered grounds for

rejection. Detached particles are revealed by means of an ultraviolet lamp.

4.6 Insolubility

4.6.1 Procedure

Immerse the deposit to a depth of at least 3 mm for 24 h in distilled water, at a temperature between 18 °C and 25 °C. Then measure the activity of the water. For 50 mg of deposit, the activity shall be less than

3,7 MBq (100 μCi) for tritium deposits, and

0,2 MBq (6 μCi) for promethium deposits.

4.6.2 Checking the insolubility

Carry out checks on standard deposits as defined in 4.1 c) which have been prepared in accordance with the instructions of the manufacturer of the luminous powder and which have undergone the test specified in 4.5.1.

Quality control may also be carried out on luminous components (dials and hands) which have undergone the tests specified in 4.5.1 and 4.5.2. The mass of the powder in the deposit shall then be measured or calculated, the maximum authorized activity of the water being considered proportional to the mass of the powder in the deposit, regardless of its activity.

Annex A
(informative)

Bibliography

- [1] CIE Publication No. 17.4:1987, *International Lighting Vocabulary*.

This page intentionally left blank

This page intentionally left blank

This page intentionally left blank

UDC 681.113/.114.033.1:535.37

Descriptors: horological industry, time measuring instruments, luminescence, radioluminescent deposit, specifications, tests.

Price based on 6 pages
