

3137-74

4851903 0016773 5

H-25-25

**INTERNATIONAL STANDARD**



**3137**

INTERNATIONAL ORGANIZATION FOR STANDARDIZATION • МЕЖДУНАРОДНАЯ ОРГАНИЗАЦИЯ ПО СТАНДАРТИЗАЦИИ • ORGANISATION INTERNATIONALE DE NORMALISATION

## **Anhydrous hydrogen fluoride for industrial use – Sampling**

*Fluorure d'hydrogène anhydre à usage industriel – Échantillonnage*

**First edition – 1974-12-15**

**UDC 661.487 : 543.05 : 620.113**

**Ref. No. ISO 3137-1974 (E)**

**Descriptors :** hydrogen fluoride, sampling, chemical analysis.

Price based on 6 pages

ISO 3137-1974 (E)

## FOREWORD

ISO (the International Organization for Standardization) is a worldwide federation of national standards institutes (ISO Member Bodies). The work of developing International Standards is carried out through ISO Technical Committees. Every Member Body interested in a subject for which a Technical Committee has been set up has the right to be represented on that Committee. International organizations, governmental and non-governmental, in liaison with ISO, also take part in the work.

Draft International Standards adopted by the Technical Committees are circulated to the Member Bodies for approval before their acceptance as International Standards by the ISO Council.

International Standard ISO 3137 was drawn up by Technical Committee ISO/TC 47, *Chemistry*, and circulated to the Member Bodies in June 1973.

It has been approved by the Member Bodies of the following countries :

Austria	India	South Africa, Rep. of
Belgium	Israel	Spain
Bulgaria	Italy	Switzerland
Czechoslovakia	Netherlands	Thailand
Egypt, Arab Rep. of	New Zealand	Turkey
France	Poland	United Kingdom
Germany	Portugal	U.S.S.R.
Hungary	Romania	

This International Standard has also been approved by the International Union of Pure and Applied Chemistry (IUPAC).

No Member Body expressed disapproval of the document.

# Anhydrous hydrogen fluoride for industrial use — Sampling

**WARNING** — Anhydrous hydrogen fluoride is a highly corrosive liquid which boils at 19,5 °C. It attacks glass, has a great affinity for water and its vapour is irritant and toxic. Its action on the skin and eyes is strongly corrosive, producing severe and painful burns which may not be immediately evident and which respond slowly to treatment.

Samples should be handled only inside a well-ventilated fume cupboard. Rubber gloves, boots and gown of a suitable size to give adequate protection to the individual, and full head and face protection must be worn when handling the material.

In the event of contact or suspected contact, flood with water and seek immediate medical attention. The manufacturers' literature should be consulted for further information.

## SECTION ONE — LABORATORY SAMPLE

### 1 SCOPE

Section one of this International Standard specifies a method for taking laboratory samples of anhydrous hydrogen fluoride, intended for the determination of the water content and the preparation of the test sample for other determinations.

### 2 FIELD OF APPLICATION

This method is applicable to the sampling of anhydrous hydrogen fluoride from road and rail tanks, drums and cylinders.

### 3 PRINCIPLE

Allowing the liquid from the bulk container to flow into a cooled evacuated stainless steel cylinder or cylinders of not less than 1 kg total capacity.

### 4 APPARATUS

The apparatus for sampling is shown in figure 1 and comprises :

**4.1 Stainless steel cylinder, A**, capable of holding at least 1 kg of sample (see also figure 2). Alternatively, several smaller cylinders of total capacity not less than 1 kg may be connected in series.

**4.2 Stainless steel coupling tube, B**, equipped at either end with stainless steel unions threaded at one end to fit into the valve E of the container holding the anhydrous hydrogen fluoride and at the other end to fit one of the screw threads of the transverse passage F of the cylinder.

**4.3 Stainless steel valve, C**, fitting to the other screw thread of the transverse passage of the cylinder.

**4.4 Stainless steel tube, D**, connecting the valve to the extraction system.

**4.5 Screw caps**, for closing the ends of the transverse passage.

**4.6 Vacuum pump**, capable of producing rapidly a pressure of about 0,6 kPa inside the cylinder.

### 5 PROCEDURE

#### 5.1 Preparation of sample cylinder

##### 5.1.1 *Cleaning and drying*

Close one end of the transverse passage F with its screw cap and connect the other end to the extraction system using the tube D. Open the valve of the cylinder to allow any residual anhydrous hydrogen fluoride in the cylinder to be extracted.

After allowing a sufficient length of time to permit complete extraction of the hydrogen fluoride, close the valve of the cylinder.

Remove the screw cap and tube to the extraction system and wash the ends of the transverse passage thoroughly with water. Open the valve G of the cylinder so that water can flow into it.

Remove and empty the cylinder, wash all parts with an excess of water and dry them for 8 to 12 h in an oven at 110 °C. Store this cylinder in the oven until required.

### 5.1.2 Evacuation

Evacuate the cylinder by means of the vacuum pump (4.6), close the valve and, if the cylinder is above 15 °C, cool it to below this temperature.

### 5.2 Taking of sample

Connect one end of the transverse passage to the valve C and connect this to the tube D leading to the fume extraction system.

Connect the tube B to the valve E of the container of the anhydrous hydrogen fluoride and to the other end of the transverse passage of the cylinder.

With the valve G of the cylinder in the closed position, open the valves E and C so that the sample can pass through the transverse passage of the cylinder to the extraction system. Allow the purge to continue for 1 to 2 min.

Close the valve C and open the valve G of the cylinder, allowing the cylinder to fill. Wait about 3 min.

Close the valve G of the cylinder, then the valve E of the anhydrous hydrogen fluoride container and finally open the valve C.

After allowing sufficient time for them to empty, disconnect the coupling tubes B and D and the valve C and close the ends of the transverse passage of the cylinder with the screw caps.

## SECTION TWO – TEST SAMPLE

### 6 SCOPE

Section two of this International Standard specifies a method for the preparation of test samples of anhydrous hydrogen fluoride.

### 7 FIELD OF APPLICATION

This method is applicable to laboratory samples taken in accordance with the method specified in section one of this International Standard.

### 8 PRINCIPLE

Introduction of the liquid anhydrous hydrogen fluoride into a polyolefin cylinder containing two layers of ice.

### 9 REAGENT

**9.1 Ice**, prepared from distilled water or from water of equivalent purity.

### 10 APPARATUS

The apparatus is shown in figure 3 and comprises :

**10.1 Dilution vessel, H**, of translucent polyolefin material, of diameter 60 mm and height 200 mm, fitted with two lugs 120 mm from the bottom of the cylinder.

**10.2 Perforated polyolefin disc, J**, resting on the side lugs of the dilution vessel H.

**10.3 Polyolefin stopper, K**, fitting on to the dilution vessel, H.

**10.4 Delivery tube, L**, of polyolefin material, 8 mm in diameter and 150 mm long.

**10.5 Copper connecting tube, M**, 8 mm in diameter and 20 mm long, fitting by means of a threaded union on one of the ends of the transverse passageway of the sample cylinder (see section one).

**10.6 Polyolefin connection sleeve, N**, to join the connecting tube M to the delivery tube L.

**10.7 Polyolefin flask**, 250 ml capacity.

### 11 PROCEDURE

**11.1** Take the previously dried dilution vessel H (10.1) and insert the perforated disc J (10.2), the delivery tube L (10.4) and the stopper K (10.3). Weigh to the nearest 0,1 g. Remove the stopper, delivery tube and perforated disc.

**11.2** Crush a quantity of the ice (9.1) to pieces of about 15 mm diameter, rinse with distilled water and introduce approximately 40 g into the dilution vessel H. Place the perforated disc J on the side lugs of the dilution vessel and introduce the delivery tube L through the centre hole of the disc. Add approximately 40 g of the ice pieces above the disc, wipe the outside of the vessel with a dry cloth to remove any condensed moisture and reweigh, with the stopper, to the nearest 0,1 g.

**11.3** Remove the screw cap from the sample cylinder A (4.1) (see section one) and connect the threaded union of the connecting tube M (10.5) to the sample cylinder. Join the connecting tube M to the delivery tube L by means of the connection sleeve N (10.6). Position the bottom end of the delivery tube L in the empty space below the perforated disc J and carefully open the cylinder valve G. Allow the anhydrous hydrogen fluoride to flow drop by drop until approximately 30 g are introduced.

11.4 Disconnect the delivery tube L and let it drop into the dilution vessel H. Insert the stopper K in the dilution vessel. Disconnect the connecting tube M from the sample cylinder A and refit the screw cap. Wipe the outside of the vessel with a dry cloth to remove any condensed moisture and reweigh the dilution vessel H to the nearest 0,1 g.

11.5 Agitate the dilution vessel H until the ice melts completely and then transfer its contents to the polyolefin flask (10.7).

## 12 CALCULATION OF CONCENTRATION

The concentration of the hydrofluoric acid solution, expressed as a percentage by mass of anhydrous hydrogen fluoride, is given by the formula

$$\frac{m_1}{m_1 + m_2} \times 100$$

where

$m_1$  is the mass, in grams, of anhydrous hydrogen fluoride introduced;

$m_2$  is the mass, in grams, of ice used.

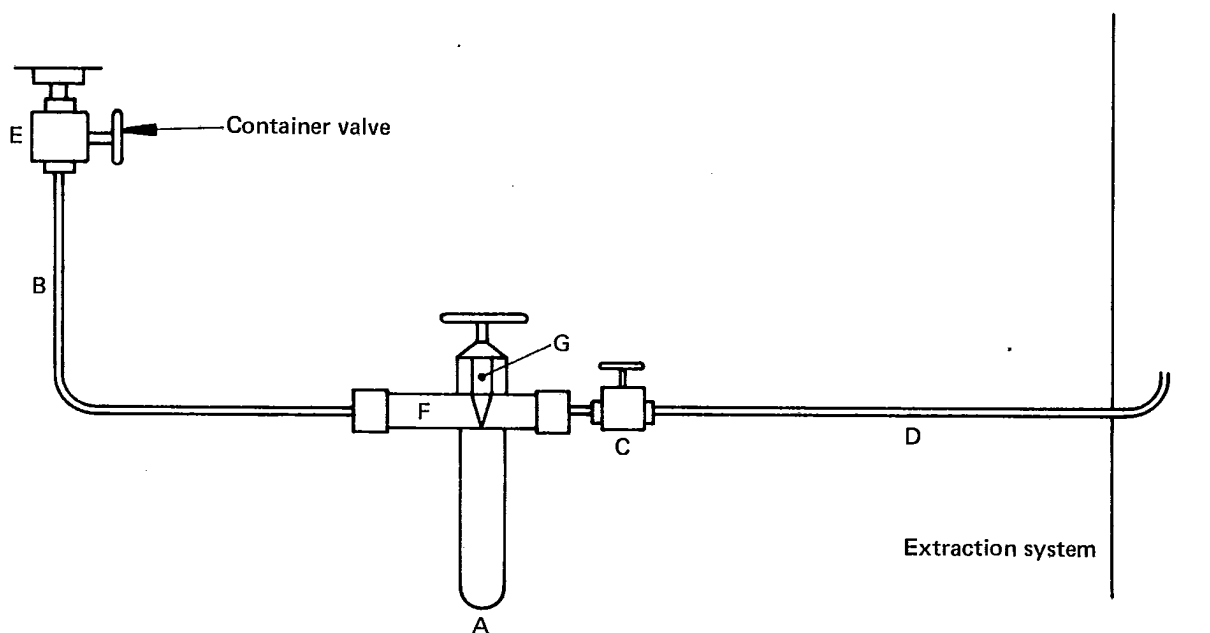

FIGURE 1 — Apparatus for sampling anhydrous hydrogen fluoride

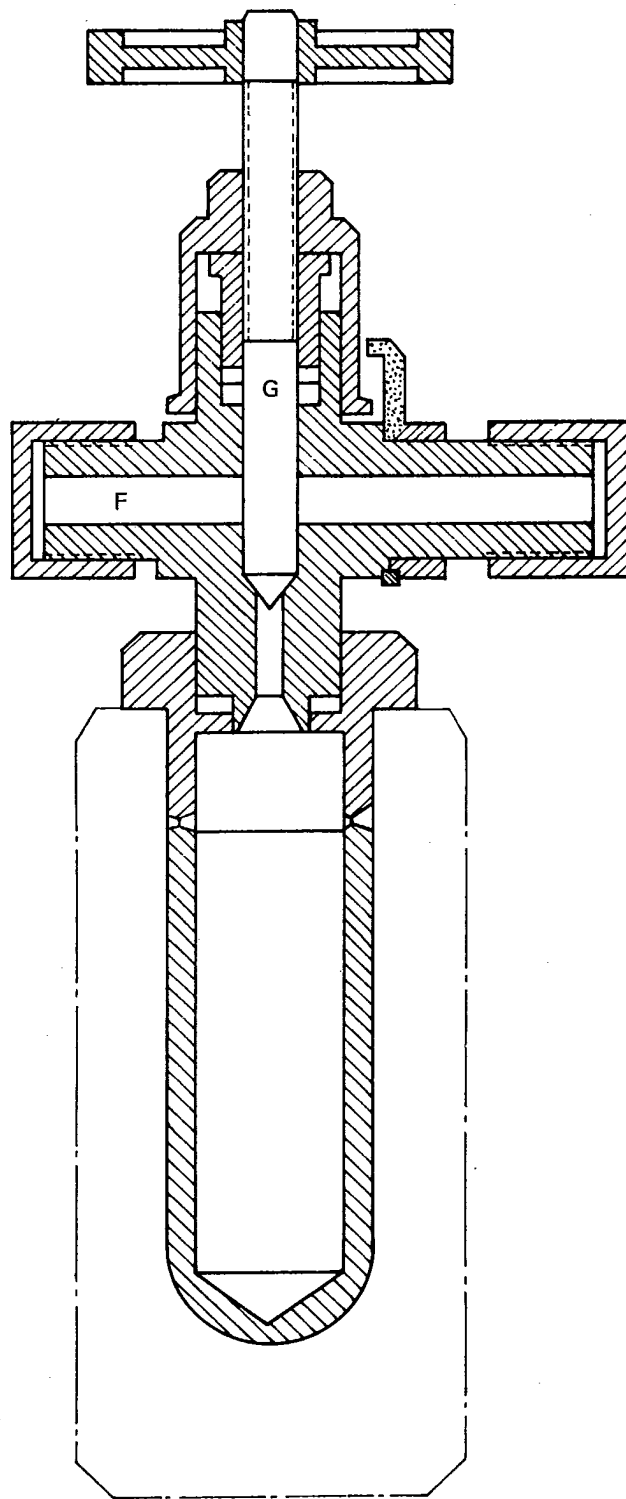

FIGURE 2 — Sample cylinder for anhydrous hydrogen fluoride (simplified diagram)

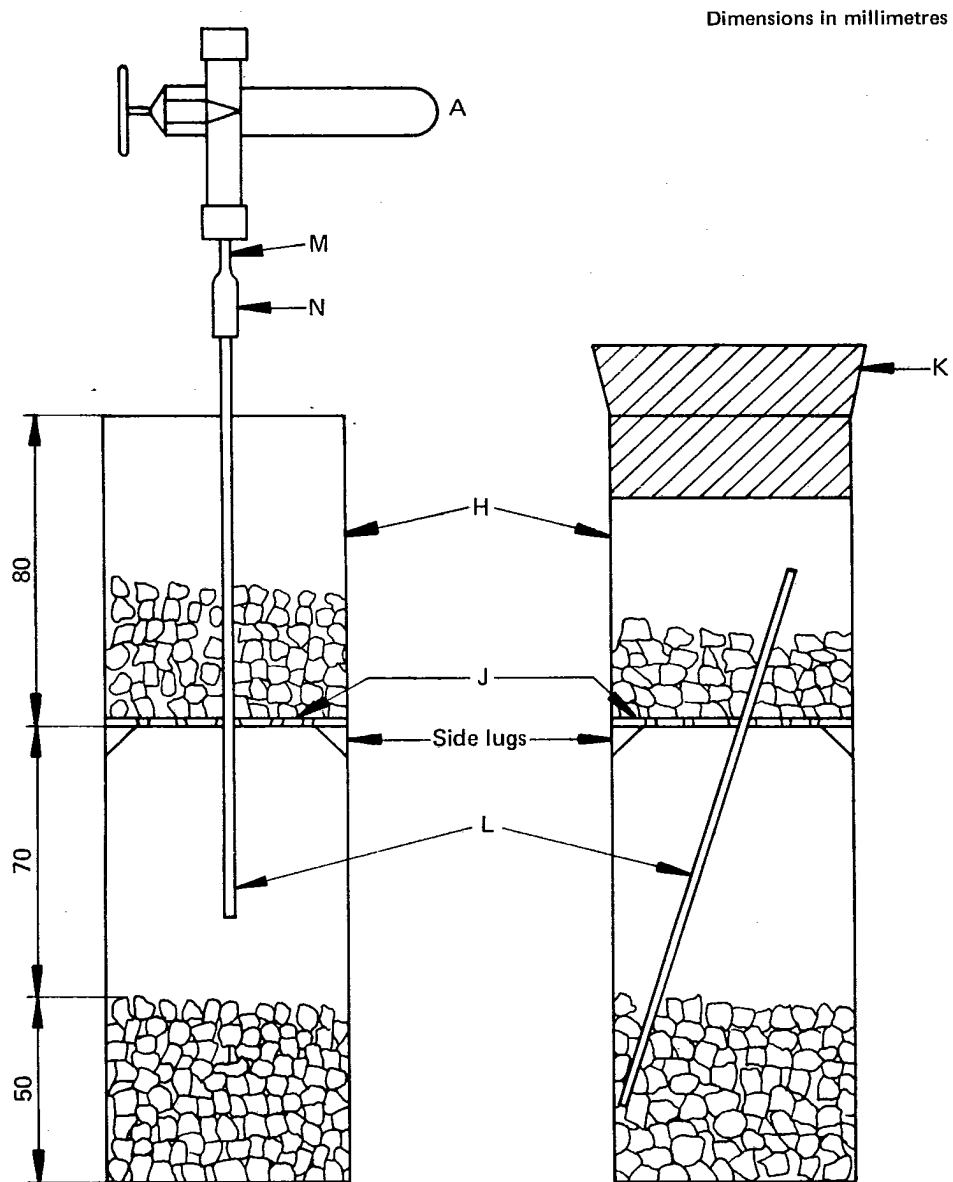

FIGURE 3 — Apparatus for preparing test samples of anhydrous hydrogen fluoride

## ANNEX

This document forms part of a series of International Standards on methods of test for anhydrous hydrogen fluoride and aqueous hydrofluoric acid for industrial use.

The complete list of the International Standards already prepared or in course of preparation is as follows :

**ANHYDROUS HYDROGEN FLUORIDE**

ISO 3137 – *Sampling.*

ISO 3138 – *Determination of non-volatile acid content – Titrimetric method.*

ISO 3699 – *Determination of water content – Karl Fischer method.*

ISO 3700 – *Determination of water content – Conductimetric method.*

ISO 3701 – *Determination of fluorosilicic acid content.*

ISO 3702 – *Determination of sulphur dioxide content.*

**AQUEOUS HYDROFLUORIC ACID**

ISO 3139 – *Sampling and methods of test.*

---