Wood — Sampling methods and general requirements for physical and mechanical testing of small clear wood specimens

Bois — Méthodes d'échantillonnage et conditions générales pour les essais physiques et mécaniques de petites éprouvettes de bois net





COPYRIGHT PROTECTED DOCUMENT

© ISO 2012

All rights reserved. Unless otherwise specified, no part of this publication may be reproduced or utilized in any form or by any means, electronic or mechanical, including photocopying and microfilm, without permission in writing from either ISO at the address below or ISO's member body in the country of the requester.

ISO copyright office
Case postale 56 • CH-1211 Geneva 20
Tel. + 41 22 749 01 11
Fax + 41 22 749 09 47
E-mail copyright@iso.org
Web www.iso.org

Published in Switzerland

Foreword

ISO (the International Organization for Standardization) is a worldwide federation of national standards bodies (ISO member bodies). The work of preparing International Standards is normally carried out through ISO technical committees. Each member body interested in a subject for which a technical committee has been established has the right to be represented on that committee. International organizations, governmental and non-governmental, in liaison with ISO, also take part in the work. ISO collaborates closely with the International Electrotechnical Commission (IEC) on all matters of electrotechnical standardization.

International Standards are drafted in accordance with the rules given in the ISO/IEC Directives, Part 2.

The main task of technical committees is to prepare International Standards. Draft International Standards adopted by the technical committees are circulated to the member bodies for voting. Publication as an International Standard requires approval by at least 75 % of the member bodies casting a vote.

Attention is drawn to the possibility that some of the elements of this document may be the subject of patent rights. ISO shall not be held responsible for identifying any or all such patent rights.

ISO 3129 was prepared by Technical Committee ISO/TC 218, *Timber*.

This second edition cancels and replaces the first edition (ISO 3129:1975), which has been technically revised.

Wood — Sampling methods and general requirements for physical and mechanical testing of small clear wood specimens

1 Scope

This International Standard specifies methods for the extensive and limited sampling of wood, conditioning and preparation of test pieces. It also specifies the general requirements for physical and mechanical testing of small clear wood specimens. The sampling guidance provided in this International Standard can be applied for timber taken from either trees, logs, or pieces of ungraded/graded/presorted sawn timber for non-structural applications, such as furniture, windows, doors, etc., only.

2 Normative references

The following referenced documents are indispensable for the application of this document. For dated references, only the edition cited applies. For undated references, the latest edition of the referenced document (including any amendments) applies.

ISO 3130, *Wood — Determination of moisture content for physical and mechanical tests*

ISO 3131, *Wood — Determination of density for physical and mechanical tests*

ISO 3132, *Wood — Testing in compression perpendicular to grain*

ISO 3133, *Wood — Determination of ultimate strength in static bending*

ISO 3345, *Wood — Determination of ultimate tensile stress parallel to grain*

ISO 3346, *Wood — Determination of ultimate tensile stress perpendicular to grain*

ISO 3348, *Wood — Determination of impact bending strength*

ISO 3349, *Wood — Determination of modulus of elasticity in static bending*

ISO 3350, *Wood — Determination of static hardness*

ISO 3351, *Wood — Determination of resistance to impact indentation*

ISO 4469, *Wood — Determination of radial and tangential shrinkage*

ISO 4858, *Wood — Determination of volumetric shrinkage*

ISO 4859, *Wood — Determination of radial and tangential swelling*

ISO 4860, *Wood — Determination of volumetric swelling*

ISO 8905, *Sawn timber — Test methods — Determination of ultimate strength in shearing parallel to grain*

ISO 24294, *Round and sawn timber — Vocabulary*

EN 1534, *Wood flooring — Determination of resistance to indentation — Test method*

3 Terms and definitions

For the purposes of this document, the terms and definitions given in ISO 24294 apply.

4 General principles

This International Standard covers procedures of sampling for obtaining small clear specimens which, when tested in accordance with methods prescribed under relevant International Standards, may provide information on the influence on mechanical properties of such factors as moisture content, density, position in cross-section, height in the tree and locality of growth.

NOTE These International Standards (ISO 3130, ISO 3131, ISO 3132, ISO 3133, ISO 3345, ISO 3346, ISO 3348, ISO 3349, ISO 3350, ISO 3351, ISO 4469, ISO 4858, ISO 4859 and ISO 4860) are currently being revised.

5 Sampling

5.1 Selection of material

The material intended for physical and mechanical tests shall be selected taking into account the purpose of the test, as well as the requirements to ensure that the properties obtained from the test pieces represent the sample population.

5.2 Sampling of wood material

The material selected shall be in the form of either logs or sawn timbers.

5.2.1 Logs

Trees or logs shall be selected to represent the population. For each species to be tested, at least five trees or logs representative of that species or species group shall be selected.

A heart plank shall be cut from a log of acceptable diameter. For a log having an eccentric structure, the heart plank shall cover the geometrical centre (Figure 1). In the case of a log having a diameter of 180 mm or less, the heart plank shall be cut in the direction of two mutually perpendicular diameters (Figure 2).

In the case of an eccentric structure, the plank shall include the pith and not the geometrical centre.

The thickness of the heart plank shall be at least 60 mm, except for logs with a diameter of 180 mm or less, where the thickness shall be 40 mm. In this case, to obtain test pieces with a cross-sectional dimension greater than 30 mm, a disc that is at least 100 mm thick shall be cut from one end of the log prior to sawing out heart planks. This disc may be used for the hardness test.

5.2.2 Matching for test of dry material

If one purpose of the sampling is to provide comparison of green and dry properties, provisions may be made for matching of specimens within the tree. The collection of the material has been arranged to provide for tests of both green and dry specimens that are closely matched by selection from adjacent parts of the same tree.

To afford matching, the sticks of one heart plank shall be interchanged with the other sticks from the next adjacent heart plank from the same tree to form two composite heart planks, each being complete and made of equal portions of the adjacent heart planks. The sticks from one of these composite heart planks shall be tested green and those from the other shall be tested after drying. Thus, the sticks of each composite heart plank shall be regarded as if they were from the same heart plank.

This procedure provides for end-to-end matching (end matching) of sticks to be tested dry with those to be tested green, which is to be preferred when practicable. If, because of the nature of the material, end matching is not practicable, side matching may be used.

5.2.3 Sawn timber

In sampling of sawn timber, sticks shall be cut parallel to the direction of the grain. A sufficient number of sticks shall be cut to ensure that the sample and its statistical properties are representative of the population. The

sticks shall be not less than 35 mm thick with sides in radial and tangential directions. Sticks containing pith shall be discarded.

6 Conditioning of material

6.1 Test pieces with a standardized moisture content (dry specimens)

Before conversion into test pieces, the wood shall be thoroughly dried (at a temperature lower than 60 °C) to a moisture content close to that of the equilibrium state and shall be conditioned at a temperature of (20 ± 2) °C and a relative humidity of (65 ± 3) % to bring the moisture content of the wood to that of equilibrium. It is desirable that the ends of the test pieces be covered with a moisture-protective substance to prevent splitting.

6.2 Test pieces with moisture content of equal to or above fibre saturation point (green specimens)

Prior to cutting into test pieces, the sticks shall be kept under controlled conditions to prevent further drying of the wood.

Dimensions in millimetres

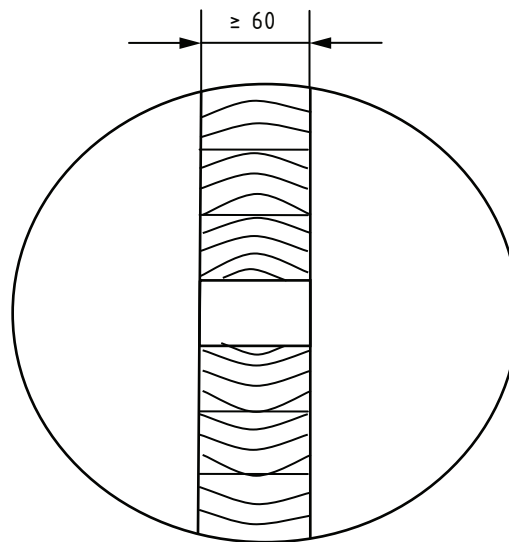

Figure 1 — General cutting pattern of heart plank from a log of diameter >180 mm

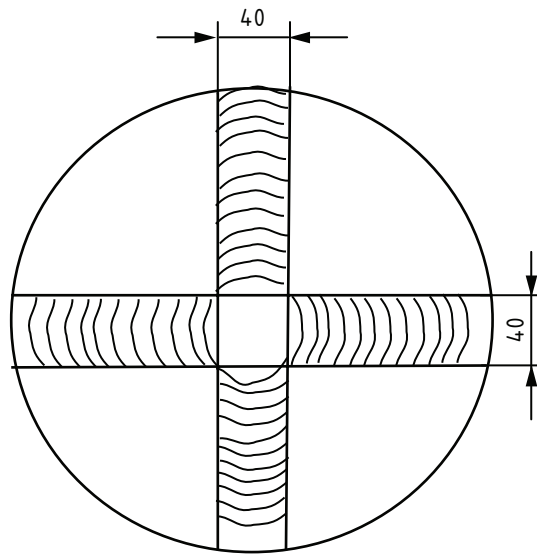

Figure 2 — General cutting pattern of heart planks from a log of diameter ≤ 180 mm

7 Preparation of test pieces

7.1 Form and dimensions

One test piece for each type of test shall be cut from each stick as specified in 5.2.2. The form and dimensions of the test pieces shall be those specified in the relevant International Standards for methods of testing small clear specimens of wood.

7.2 Direction of grain

The wood shall be cut with the grain parallel to the longitudinal axis of the test pieces. Growth rings on the end surfaces of test pieces shall be parallel to one pair of opposite faces and perpendicular to the other pair. Adjacent faces shall be at right angles. In the case of tropical timbers where the growth ring is not clear, the cutting shall follow the direction of the rays on the cross-section which represents the radial surface of the test pieces.

7.3 Permissible deviations

The permissible deviations of the gauge length of the test pieces from nominal dimensions shall not exceed $\pm 0,1$ mm. The dimensions of test pieces not used in calculations (for example, the length of the test piece for the static bending test) shall be kept to an accuracy of ± 1 mm. The working surfaces of the test pieces shall be clean finished.

7.4 Marking

Each test piece obtained from a heart plank shall be numbered to indicate its original position in the plank. In the case of sawn timber, each test piece shall be numbered to indicate the stick from which they were cut. The piece marking shall indicate whether each piece was cut from sapwood or heartwood, if they are differentiated.

7.5 Sample size/number

7.5.1 Random sampling

The number of test pieces shall be specified, taking into account

- the purpose of the testing, for example, determination of the quality of standwood or of a model tree or of a lot of timber or of an individual board,
- the type of sampling method used, and
- the degree of test precision required.

The average values of the physical and mechanical properties shall be determined to an accuracy of $p \leq 0,05$ at a confidence level of 95 %.

7.5.2 Selective sampling

In selective sampling, the minimum number of test pieces, n_{\min} , is given by the following formula:

$$n_{\min} = mn = \frac{C_V^2 t^2}{p^2} \left[\frac{\left(\frac{n\sigma_b^2}{\sigma_j^2} \right) + 1}{\left(\frac{\sigma_b^2}{\sigma_j^2} \right) + 1} \right] \quad (1)$$

where

- m is the quantity of selected material (logs, sawn timber, boards, etc.);
- n is the mean number of test pieces cut from each piece of the selected material;
- C_V is the percentage coefficient of variation for the property to be determined (refer to Table 1);
- t is the index of result authenticity (a half-length of the confidence interval in fractions of the standard deviation);
- p is the percentage index of test precision (the relation between the standard deviation of the arithmetic mean and the arithmetic mean);
- σ_b^2 is the expected variance of the property between trees;
- σ_j^2 is the expected variance of the property within trees.

The results shall be rounded to the nearest integer.

7.5.3 Mechanical sampling

In mechanical sampling, the minimum number of test pieces, n_{\min} , is given approximately by the formula:

$$n_{\min} = \frac{C_V^2 t^2}{p^2} \quad (2)$$

where C_V , t and p are as defined in 7.5.2.

The results shall be rounded to the nearest integer.

7.5.4 Minimum number of test pieces

For an approximate determination of the minimum number of test pieces, the mean values of the coefficients of variation for wood properties shown in Table 1 may be used, except for resistance to impact indentation.

For the purpose of determining the number of test specimens for this property, reference shall be made to EN 1534, since there was no reference specifying the coefficient of variation of impact indentation (up to the date of this standard being prepared), and based on the requirement of EN 1534 which stated that the number of test specimens to be sampled shall be according to the number of indentations carried out on each test specimen with a total number of indentations of at least 50. If three indentations are required on each radial and tangential surfaces for each test specimen, and the number of test pieces is 30, the total number of indentations is 180. Hence $n = 30$ will satisfy the requirement of EN 1534 and thus is recommended for the test for the determination of resistance to impact indentation

Table 1 – Mean values of the coefficients of variation for wood properties

Wood property	Coefficient of variation
	%
Number of growth rings in 1 cm	37
Percentage of late wood	28
Density	10
Equilibrium moisture content	5
Coefficient of shrinkage: linear	28
Coefficient of shrinkage: volumetric	16
Ultimate compressive strength parallel to grain	13
Ultimate strength in static bending	15
Ultimate shearing strength parallel to grain	20
Modulus of elasticity in static bending	20
Proportional limit (conventional ultimate strength) in compression perpendicular to grain	20
Ultimate tensile strength: parallel to grain	20
Ultimate tensile strength: perpendicular to grain	20
Impact strength in bending	32
Hardness	17

7.6 Conditioning of test pieces

7.6.1 Testing at equilibrium moisture content

Test pieces that have been prepared according to 6.1 shall be conditioned at a temperature of (20 ± 2) °C and a relative humidity of (65 ± 2) % to bring the moisture content of the wood to that of equilibrium.

In certain climatic conditions, test pieces may be conditioned at a temperature above 20 °C with the appropriate change in relative humidity to obtain the same equilibrium moisture content.

7.6.2 Testing at fibre saturation point

Test pieces that have been prepared according to 6.2 shall have a moisture content equal to or greater than the fibre saturation point. In the event that the moisture content of the test pieces is below this point, the test pieces shall be soaked prior to testing until no further changes in dimensions are recorded. This provision, however, is only allowed for compression and shear tests.

7.6.3 Storage

After conditioning, test pieces shall be stored under controlled conditions to ensure that their moisture content remains unchanged until the test is carried out.

8 General requirements for physical and mechanical tests

8.1 Temperature and humidity conditions in the laboratory

The temperature in the laboratory where the tests are carried out shall be maintained at (20 ± 2) °C. The relative humidity should preferably be (65 ± 2) %.

8.2 Procedure

Carry out the tests in accordance with the relevant International Standards.

NOTE These standards (ISO 3130, ISO 3131, ISO 3132, ISO 3133, ISO 3345, ISO 3346, ISO 3348, ISO 3349, ISO 3350, ISO 3351, ISO 4469, ISO 4858, ISO 4859, ISO 4860, ISO 8905) are currently being revised under ISO 13061, Parts 1-15.

After the tests have been carried out, determine the moisture content and, when required, the density of the test pieces. It is recommended that the moisture content be determined on samples cut from the test pieces. The minimum number of test pieces, n_w , used for the determination of their mean moisture content shall be at least 3 and is given by the formula:

$$n_w = n_{\min} \frac{C_{V,w}^2}{C_V^2} \quad (3)$$

where

n_{\min} is the number of test pieces used for the determination of an index of a wood property with coefficient of variation C_V ;

$C_{V,w}$ is the coefficient of variation for the moisture content of the test pieces (refer to Table 1).

The results shall be rounded to the nearest whole number.

9 Calculation and expression of results

The values of the wood properties shall be calculated using the formulae given in this International Standard for the appropriate test methods.

In treating the test results, the following shall be estimated:

— the arithmetic mean, \bar{x} , from the formula:

$$\bar{x} = \sum \frac{\bar{x}_i}{n} \quad (4)$$

— the standard deviation, s , from the formula:

$$s = \sqrt{\frac{\sum (x_i - \bar{x})^2}{n-1}} \quad (5)$$

— the standard deviation, $s_{\bar{x}}$, of the arithmetic mean, from the formula:

$$s_{\bar{x}} = \frac{s}{\sqrt{n}} \quad (6)$$

— the percentage coefficient of variation, C_V , from the formula:

$$C_V = \frac{s}{\bar{x}} \times 100 \quad (7)$$

— the percentage index of test precision, p , at a confidence limit of 0,95, from the formula:

$$p = \frac{2s_{\bar{x}}}{\bar{x}} \times 100 \quad (8)$$

where

x is the value of an individual observation;

n is the number of observations.

If necessary, the test results should be adjusted to a 12 % moisture content. If the mean moisture content is determined from the moisture content of several test pieces, it is permissible to correct the arithmetic mean of the test results for moisture content.

10 Test report

The results of measurements and calculations shall be stated in the test report. The following shall also be indicated in the test report:

- a) a reference to this International Standard, i.e. ISO 3129:2012;
- b) the type of test;
- c) the direction of the applied load;
- d) temperature and air humidity in the laboratory;
- e) species of wood;
- f) details concerning sampling of the test pieces.

Bibliography

- [1] ASTM D143, *Standard Test Methods for Small Clear Specimens of Timber*
- [2] ASTM D5536, *Standard Practice for Sampling Forest Trees for Determination of Clear Wood Properties*

