

INTERNATIONAL STANDARD

ISO 3126

Second edition
2005-03-01

Plastics piping systems — Plastics components — Determination of dimensions

*Systèmes de canalisations en plastiques — Composants en
plastiques — Détermination des dimensions*



Reference number
ISO 3126:2005(E)

© ISO 2005

PDF disclaimer

This PDF file may contain embedded typefaces. In accordance with Adobe's licensing policy, this file may be printed or viewed but shall not be edited unless the typefaces which are embedded are licensed to and installed on the computer performing the editing. In downloading this file, parties accept therein the responsibility of not infringing Adobe's licensing policy. The ISO Central Secretariat accepts no liability in this area.

Adobe is a trademark of Adobe Systems Incorporated.

Details of the software products used to create this PDF file can be found in the General Info relative to the file; the PDF-creation parameters were optimized for printing. Every care has been taken to ensure that the file is suitable for use by ISO member bodies. In the unlikely event that a problem relating to it is found, please inform the Central Secretariat at the address given below.

© ISO 2005

All rights reserved. Unless otherwise specified, no part of this publication may be reproduced or utilized in any form or by any means, electronic or mechanical, including photocopying and microfilm, without permission in writing from either ISO at the address below or ISO's member body in the country of the requester.

ISO copyright office
Case postale 56 • CH-1211 Geneva 20
Tel. + 41 22 749 01 11
Fax + 41 22 749 09 47
E-mail copyright@iso.org
Web www.iso.org

Published in Switzerland

Foreword

ISO (the International Organization for Standardization) is a worldwide federation of national standards bodies (ISO member bodies). The work of preparing International Standards is normally carried out through ISO technical committees. Each member body interested in a subject for which a technical committee has been established has the right to be represented on that committee. International organizations, governmental and non-governmental, in liaison with ISO, also take part in the work. ISO collaborates closely with the International Electrotechnical Commission (IEC) on all matters of electrotechnical standardization.

International Standards are drafted in accordance with the rules given in the ISO/IEC Directives, Part 2.

The main task of technical committees is to prepare International Standards. Draft International Standards adopted by the technical committees are circulated to the member bodies for voting. Publication as an International Standard requires approval by at least 75 % of the member bodies casting a vote.

Attention is drawn to the possibility that some of the elements of this document may be the subject of patent rights. ISO shall not be held responsible for identifying any or all such patent rights.

ISO 3126 was prepared by the European Committee for Standardization (CEN) in collaboration with Technical Committee ISO/TC 138, *Plastics pipes, fittings and valves for the transport of fluids*, Subcommittee SC 5, *General properties of pipes, fittings and valves of plastic materials and their accessories — Test methods and basic specifications*, in accordance with the Agreement on technical cooperation between ISO and CEN (Vienna Agreement).

Throughout the text of this document, read “...this European Standard...” to mean “...this International Standard...”.

This second edition cancels and replaces the first edition (ISO 3126:1974), which has been technically revised.

Contents	page
Foreword	v
1 Scope	1
2 Normative references	1
3 Terms, definitions and symbols	1
3.1 Terms and definitions.....	1
3.2 Symbols	1
4 Measuring devices	2
4.1 General requirements	2
4.2 Instruments	2
5 Determination of dimensions	3
5.1 General	3
5.2 Wall thicknesses	4
5.3 Diameters.....	5
5.4 Out-of-roundness	6
5.5 Pipe lengths	6
5.6 End squareness of pipes and fittings.....	7
6 Determination of other geometrical characteristics related to fittings	8
6.1 General	8
6.2 Bends	9
6.3 Branches	12
6.4 Reducers.....	14
7 Flanges, loose flanges and collar	15
7.1 General	15
7.2 Outside diameter of the flange, loose flange and collar.....	17
7.3 Bore diameter of the flange or collar.....	17
7.4 Bolt hole diameter	17
7.5 Bolt hole distribution.....	17
7.6 Concentricity of bolt circle diameter	17
7.7 Pitch circle diameter.....	17
7.8 Shoulder diameter of flange and collar	18
7.9 Flange and collar thickness	18
7.10 Length of the flange and collar.....	18
8 Other measurements	18
Bibliography	19

Foreword

This document (EN ISO 3126:2005) has been prepared by Technical Committee CEN /TC 155, "Plastics piping systems and ducting systems", the secretariat of which is held by NEN in collaboration with Technical Committee ISO/TC 138 "Plastics pipes, fittings and valves for the transport of fluids".

This European Standard shall be given the status of a national standard, either by publication of an identical text or by endorsement, at the latest by September 2005, and conflicting national standards shall be withdrawn at the latest by September 2005.

This document is one of a series of standards on test methods, which support system standards for plastics piping systems and ducting systems.

According to the CEN/CENELEC Internal Regulations, the national standards organizations of the following countries are bound to implement this European Standard: Austria, Belgium, Cyprus, Czech Republic, Denmark, Estonia, Finland, France, Germany, Greece, Hungary, Iceland, Ireland, Italy, Latvia, Lithuania, Luxembourg, Malta, Netherlands, Norway, Poland, Portugal, Slovakia, Slovenia, Spain, Sweden, Switzerland and United Kingdom.

1 Scope

This document specifies methods for measurement and/or determination of the dimensions of plastics pipes and fittings and the accuracy of the measurement.

It specifies procedures for measuring angles, diameters, lengths, squareness and wall thicknesses for the purposes of checking conformity to geometric limits.

NOTE This document is using metric units. However the procedures and tolerances are applicable to other units by using appropriate conversion factors.

2 Normative references

The following referenced documents are indispensable for the application of this document. For dated references, only the edition cited applies. For undated references, the latest edition of the referenced document (including any amendments) applies.

ISO/R 463, *Dial gauges reading in 0,01 mm, 0,001 in and 0,0001 in.*

ISO 3599, *Vernier callipers reading to 0,1 and 0,05 mm.*

ISO 3611, *Micrometer callipers for external measurement.*

ISO 6507-1, *Metallic materials — Vickers hardness test — Part 1: Test method.*

3 Terms, definitions and symbols

3.1 Terms and definitions

For the purposes of this document, the following terms and definitions apply.

3.1.1

accuracy

closeness of agreement between a test result and the accepted reference value

NOTE The term "accuracy", when applied to a set of test results, involves a combination of random components and a common systematic error or bias component (ISO 3534-1).

3.1.2

calibration

set of operations that establish, under specified conditions, the relationship between values of quantities indicated by a measuring instrument or measuring system, or values represented by a material measure or a reference material, and the corresponding values realised by standards

3.1.3

reference standard

internationally accepted definition of a given unit of measurement

3.2 Symbols

b_1 : distance between the edge of a flange bolt hole and its bore

b_2 : distance between the edge of a flange bolt hole and its outside diameter

b_3 : distance between the centre of a flange bolt hole and its bore

b_4 : distance between the centre of a flange bolt hole and its outside diameter

c_1 : distance between the edges of two adjacent flange bolt holes

c_2 : distance between the centres of two adjacent flange bolt holes

ISO 3126:2005(E)

- d_e : outside diameter of a (part of a) component
- $d_{i,m}$: mean inside diameter of the main of a branch
- d_1 : outside diameter of a socket end
- d_2 : outside diameter of a spigot end
- d_3 : bore of a flange
- d_4 : diameter of a flange bolt hole
- D : outside diameter of a flange
- e : wall thickness of a component
- k : pitch circle diameter of a flange
- $L_{e,b}$: effective length of a branch
- $L_{e,m}$: effective length of the main of a branch
- $L_{e,r}$: effective length of a reducer
- $L_{e,so}$: effective length of the socket end of a fitting
- $L_{e,sp}$: effective length of the spigot end of a fitting
- L_{str} : length of the straight part of a socket or a spigot end of a fitting
- L_t : length of the tapered part of a reducer
- L_1 : maximum out-of-squareness distance from theoretical
- L_2 : measured distance from the root of the angle between a straight ruler and a reference surface to the component along the surface
- L_3 : measured distance from the root of the angle between a straight ruler and a reference surface to the component along the ruler
- L_4 : vertical distance from a reference surface to the nearest point of the upper end
- L_5 : socket insertion depth
- L_6 : overall length of a branch main
- L_7 : distance, measured in the centre-line plane of a branch, between the end of the branch spigot or socket to the bottom of the main
- L_8 : overall length of a reducer
- L_9 : distance between the edges of two selected bolt holes of a flange
- L_{10} : overall length of a flange in axial direction
- γ : calculated angle of out-of-squareness
- θ : angle of bend or branch

4 Measuring devices

4.1 General requirements

4.1.1 Accuracy of measuring devices

The measuring device shall be selected so that together with the associated procedures used the required accuracy of the measured dimension is obtained.

4.1.2 Calibration

Device used for measuring shall be calibrated at regular intervals of time in accordance with the quality plan of the user of this document. The calibration shall be traceable to an accredited reference standard (see 3.1.3).

4.2 Instruments

4.2.1 Contact instruments

4.2.1.1 In use the instruments shall not apply a force to the surface of the test piece that will cause local deformation.

4.2.1.2 Measuring devices that require contact between the test piece and one or more surfaces, e.g. a tube micrometer, shall conform to the following:

- a) the surface in contact with the internal surface of a component shall have a radius less than that of the test piece surface with which it is in contact;
- b) the surface in contact with the external surface of a component shall be either flat or radiused;
- c) the contact surfaces of the instrument shall have a hardness not less than 500 HV when tested in accordance with ISO 6507-1.

4.2.1.3 Micrometer callipers shall conform to ISO 3611 if applicable. Vernier callipers shall conform to ISO 3599 if applicable.

4.2.1.4 If the measuring instrument incorporates a dial gauge, it shall conform to ISO/R 463.

4.2.1.5 If the device comprises a circumference tape (π tape), it shall be graduated in diameters expressed in millimetres. When a force of 2,5 N is applied in the longitudinal direction to the extremities of the tape, the elongation of the tape shall not exceed 0,05 mm/m.

4.2.1.6 Measuring instruments may be used in conjunction with a setting standard of calibrated thickness or length, and then used as a comparator, i.e. to measure small differences between the setting piece and the measured dimension on the test piece.

NOTE This is particularly recommended when measuring large diameter or thick walled components.

4.2.1.7 Go/no-go gauges may be used for checking conformity to specific limits.

4.2.1.8 Contact instruments other than those mentioned in 4.2.1.3, 4.2.1.4, 4.2.1.5 and 4.2.1.7 may also be used. Ultrasonic measuring devices shall be regarded as non-contact instruments (see 4.2.2).

4.2.2 Non-contact instruments

If non-contact instruments or devices based on e.g. optical or ultrasonic scanning devices are used, the accuracy of measurement shall conform to accuracy levels specified in the relevant subclause of Clause 5 or their use shall be restricted to finding relevant positions for measurements to be made by other means, e.g. points comprising maximum or minimum dimensions.

5 Determination of dimensions

5.1 General

5.1.1 Ensure that measurement of dimensions is carried out by personnel trained in the applicable equipment and procedures.

5.1.2 Unless otherwise specified in the referring standard, ensure that either:

- a) the temperature of the measuring device, the test piece and the ambient air temperature are at (23 ± 2) °C; or
- b) results are correlated by calculation or experience to their value at 23 °C.

5.1.3 Examine the test piece surface for any features that could affect dimensional measurements, e.g. marking, parting lines, blisters or inclusions. If found, record their nature and effects on the measurement.

5.1.4 For selection of the cross-section(s) in which to make measurements, one or more of the following shall apply, as applicable:

- a) select cross-section(s) as specified by the referring standard;
- b) identify a cross-section not less than 25 mm from the end or in accordance with the component manufacturer's specification;
- c) for measurements of a dimension associated with another dimension, e.g. to enable calculation of a further dimension, the cross-section shall be appropriate to the dimension to be calculated.

5.1.5 Results of measurements are rounded as specified in 5.2.3, 5.3.3 and 5.3.4. When determining mean values the rounding shall be done after the arithmetic mean value has been calculated.

5.2 Wall thicknesses

5.2.1 General

Select instrument(s) or device(s) and associated procedures for measuring wall thickness so that the accuracy of the result is within the limits given in Table 1, unless otherwise specified in the referring standard.

Table 1 — Measurement of wall thickness

Dimensions in millimetres		
Wall thickness	Required accuracy of individual result	Round arithmetic mean value to the nearest: ^a
≤ 10	0,03	0,05
> 10 and ≤ 30	0,05	0,1
> 30	0,1	0,1
^a Exactly intermediate values shall be rounded up.		

5.2.2 Maximum and minimum wall thicknesses

Move the measuring device until the positions of the maximum and/or minimum wall thicknesses as appropriate in the selected cross-sections are found and record the observed value(s).

5.2.3 Mean wall thickness

In each selected cross-section, take at least six measurements of the wall thickness at regular intervals around the circumference.

From the values obtained, calculate the arithmetic mean value, round in accordance with Table 1 and record the answer as the mean wall thickness, e_m .

5.3 Diameters

5.3.1 General

5.3.1.1 Select the instrument(s) or device(s) and associated procedures for measuring diameters (outside or inside) of the test piece at the selected cross-section(s), so that the accuracy of the result is in accordance with Table 2, unless otherwise specified in the referring standard.

Table 2 — Measurement of diameter

Dimensions in millimetres		
Nominal diameter DN	Required accuracy of individual result	Round arithmetic mean value to the nearest: ^a
≤ 600	0,1	0,1
600 < DN ≤ 1600	0,2	0,2
> 1600	1	1
^a Exactly intermediate values shall be rounded up.		

5.3.1.2 For measuring the diameter(s) of components, select the relevant cross-section(s) in accordance with 5.1.4.

5.3.2 Measurement of maximum and minimum diameter

Move the measuring device in each selected cross-section until the appropriate extreme value(s) of the diameter are found and record the observed value(s).

5.3.3 Mean outside diameter

The mean outside diameter, $d_{e,m}$, may be determined from either:

- direct measurement using a π -tape; or
- a calculated value derived from a series of individual measurements conforming to Table 3, taken at regular intervals around each of the selected cross-sections.

In case of item b), calculate the arithmetic mean of the individual measurements, round in accordance with Table 2 and record the answer as the mean outside diameter, $d_{e,m}$.

**Table 3 — Number of individual diameter measurements
for a given nominal size**

Nominal size of pipe or fitting	Number of individual diameter measurements required in a given cross section
≤ 40	4
> 40 and ≤ 600	6
> 600 and ≤ 1600	8
> 1600	12

5.3.4 Mean inside diameter

Using a device conforming to 5.3.1.1, determine either:

- a series of individual measurements conforming to Table 3 at regular intervals; or
- direct measurement using an inside π -tape.

Calculate the arithmetic mean of the individual measurements obtained in a), round in accordance with Table 2 and record it as the applicable mean inside diameter, $d_{i,m}$.

5.3.5 Neutral diameter

Using the values determined in accordance with 5.2 and/or 5.3 without rounding, calculate the mean diameter, d_m , using one of the following equations as applicable:

$$d_m = d_{e,m} - e_m;$$

$$d_m = d_{i,m} + e_m;$$

$$d_m = 0,5(d_{e,m} + d_{i,m}).$$

where:

$d_{e,m}$ is the mean outside diameter at the appropriate cross-section;

e_m is the mean wall thickness at the appropriate cross-section;

$d_{i,m}$ is the mean inside diameter at the appropriate cross-section.

Record the calculated mean diameter after rounding in accordance with Table 2.

NOTE This procedure is not applicable to thermoplastics structured-wall pipes and fittings.

5.4 Out-of-roundness

Determine the extreme values of the specified diameter in the chosen cross-section in accordance with 5.3.2 with the accuracy as specified in Table 4 and calculate the out-of-roundness as defined in the relevant product standard.

Table 4 — Accuracy for out-of-roundness measurement

Nominal diameter DN	Required accuracy of individual result
≤ 315	0,1
315 < DN ≤ 600	0,5
> 600	1

5.5 Pipe lengths

5.5.1 Select measuring instrument(s) or device(s) and associated procedures so that the accuracy of the result is in accordance with Table 5 unless otherwise specified in the referring standard.

Table 5 — Measurement of lengths

Length mm	Required accuracy of individual result	Round arithmetic mean value to the nearest: ^a
≤ 1000	1 mm	1 mm
> 1000	0,1 %	1 mm

^a Exactly intermediate values shall be rounded up.

5.5.2 Use equipment conforming to 5.5.1 to determine the overall length and/or the effective length, as applicable, of an individual pipe.

To determine the overall length of the pipe, take measurements along the internal or external surface, parallel to the axis of the pipe, on at least three positions spaced at regular intervals around its circumference. Pipes cut by a machine that ensures a square cut need only to be measured in one position.

When applicable calculate the arithmetic mean value from the measured values, round in accordance with Table 5 and record the result as the overall length of the pipe.

From the overall length of the pipe, subtract the socket insertion depth(s), if any, and record the result obtained as the effective length of the pipe.

5.6 End squareness of pipes and fittings

5.6.1 General

Select instrument(s) or device(s) and associated procedure for measuring the end squareness of pipes and fittings so that the estimated accuracy of measurement is 0,5 mm for $DN \leq 200$ and 1 mm for $DN > 200$ unless otherwise specified in the referring standard.

5.6.2 Principle

The following procedures assume that the outside surface of the pipe or fitting is parallel to its longitudinal axis. It is also assumed that either a steel square or plumb bob is used as the reference plane though any equipment capable of being set square to the components axis can be used. The steel square technique is suitable for small and medium size components whereas the plumb bob is suitable for medium or large size components.

In accordance with Figure 1, a steel square or a plumb bob is positioned such that it touches the components. The out-of-squareness, γ , is then calculated using the measured outside diameter and the measured distance, L_1 , (see Figure 1).

If the end of the pipe or fitting is square to its longitudinal axis there will not be any difference in the distance to a reference plane that is known to be square to its longitudinal axis and from any two diametrical points at the end of the component (see Figure 1).

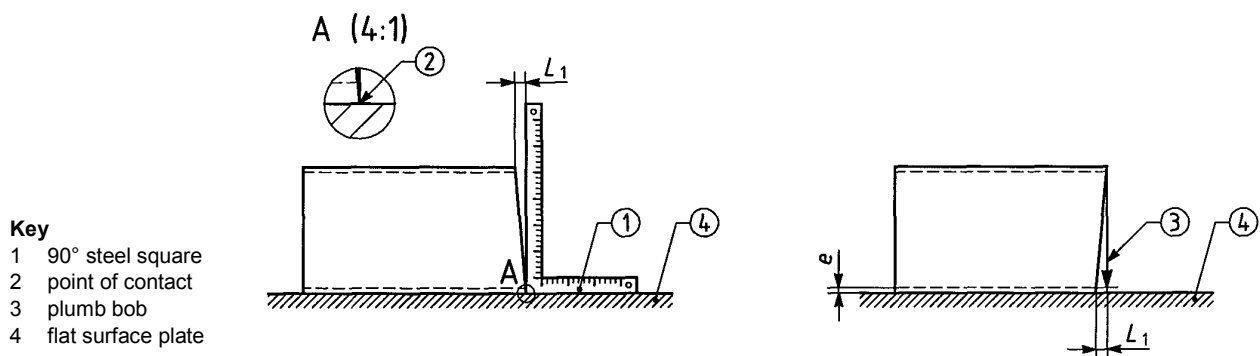

Figure 1 — Determination of end squareness

5.6.3 Procedure

5.6.3.1 Using a steel square

Determine the outside diameter of the component as described in 5.3.3.

Place the component on a horizontal flat surface plate. Use as necessary packing between the component and the surface to overcome problems such as sockets or other protrusions that cause the component axis not to be parallel to the surface.

Position the square as shown in Figure 1 so that it touches the component across its diameter.

Rotate the component until it is in the position where the gap between the square and the pipe end is maximised. If the square only touches at one point, determine and record the maximum distance, L_1 , (see Figure 1) at the point diametrically opposite the point of contact.

Unless otherwise specified in the referring standard calculate the out-of-squareness using the following equation:

$$\gamma = \arctan \frac{L_1}{d_e}$$

where:

- γ is the out-of-squareness, in degrees;
- L_1 is the maximum difference between the upper and lower distances to the plane, in millimetres;
- d_e is the outside diameter of the component, in millimetres.

5.6.3.2 Using a plumb bob

Determine the outside diameter of the component as described in 5.3.3.

Place the component on a horizontal flat surface plate. Use as necessary packing between the component and the surface to overcome problems such as sockets or other protrusions that cause the component axis not to be parallel to the surface.

Position the plumb bob at the top of the component as shown in Figure 1 and adjust its length so that the distance between the bob and the surface corresponds to the wall thickness of the component.

Rotate the component until it is in the position where the gap between the plumb bob and the pipe end is maximised.

If the plumb bob does not touch the component at the point in contact with the surface then determine and record the maximum distance L_1 (see Figure 1) at the point diametrically opposite the point of contact.

Unless otherwise specified in the referring standard calculate the out-of-squareness using the following equation:

$$\gamma = \arctan \frac{L_1}{d_e}$$

where:

- γ is the out-of-squareness, in degrees;
- L_1 is the maximum difference between the upper and lower distances to the plane, in millimetres;
- d_e is the outside diameter of the component, in millimetres.

6 Determination of other geometrical characteristics related to fittings

6.1 General

Subclauses 6.2 to 6.4 give accuracy requirements and at least one procedure or method for measuring characteristics of the following types of components:

- 6.2 Bends;
- 6.3 Branches;
- 6.4 Reducers.

Alternative equipment and/or procedures to those given in these clauses may be used providing the measurement accuracy conforms to 6.2.1, 6.3.1, 6.4.1 and 7.1 as applicable.

Table 6 — Other measurements

Dimensions in millimetres unless otherwise stated

Measurement of:	Required accuracy of individual result	Round arithmetic mean value to the nearest: ^a
Linear dimensions:		
≤ 10	0,1	0,1
> 10 and ≤ 200	0,5	1
> 200 and ≤ 1000	1	1
> 1000 and ≤ 4000	0,1 %	1
Angular dimensions	1°	1°
^a Exactly intermediate values shall be rounded up.		

6.2 Bends

6.2.1 General

Select instrument(s) or device(s) and associated procedures used for measuring dimensions of bends so that the accuracy of the individual result is in accordance with Table 6, unless otherwise specified by the referring standard.

Before starting the measurements, the squareness of the fitting ends shall be checked using the procedures described in 5.6. If an end is not square to its axis, this shall be taken into consideration in the calculation.

6.2.2 Angular change and effective length

Determine the angular change and effective length of the bend as follows:

- using the procedures described in 5.3.3, measure and record the mean outside diameters d_1 and d_2 of the ends of the component;
- using a device such as a vernier calliper or micrometer depth gauge, measure, if applicable, the socket insertion depth, L_5 , as defined in the referring standard;
- lay one end of the bend on the surface or the reference surface as shown in Figure 2;
- lay a straight edge long enough to touch the reference surface across the diameter of the upper end as shown in Figure 2;
- using a steel square or other device, measure and record the length L_4 [see Figure 2a) or Figure 2b), as applicable];
- measure and record the lengths L_2 and L_3 [see Figure 2a) or Figure 2b), as applicable];
- measure or calculate the angle θ , using an instrument or the following equation. The accuracy of the result shall be in accordance with Table 5.

$$\theta = \arcsin \frac{L_4}{L_3}$$

If applicable compensate for out-of-squareness of one or both ends of the component.

Calculate the effective length, L_e (see Figure 2), using one of the following equations as applicable:

$$L_{e,so} = L_4 + \frac{0,5d_2}{\sin \theta} - \frac{L_2 + 0,5d_1}{\tan \theta} - L_5, \text{ if the lower end is a socket [see Figure 2a)];}$$

$$L_{e,sp} = L_4 + \frac{0,5d_1}{\sin \theta} - \frac{L_2 + 0,5d_2}{\tan \theta}, \text{ if the lower end is a spigot [see Figure 2b)].}$$

where:

- d_1 is the mean outside diameter of the socket;
- d_2 is the mean outside diameter of the spigot;
- L_2 is the measured length along the surface or reference surface from the straight edge to the component [see Figure 2a) or Figure 2b), as applicable];
- L_4 is the vertical distance from the surface or reference surface to the nearest point of the upper end (see Figure 2);
- L_5 is the socket insertion depth (measured or given) as specified in the referring standard.
- θ is the fitting angle;

Record the value obtained for $L_{e,sp}$ and/or $L_{e,so}$ after rounding in accordance with Table 6.

NOTE In case of an all-socket or all-spigot component d_2 respectively d_1 should be replaced by d_1 or d_2 in the corresponding equation.

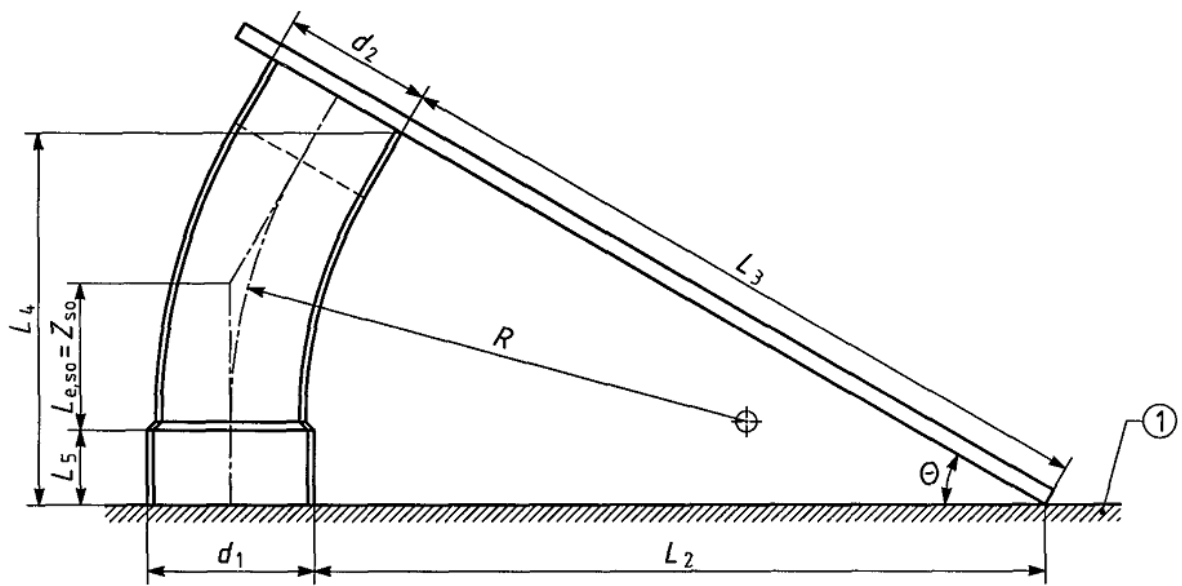

Key
 1
 Reference
 surface

a) bend with socketed lower end

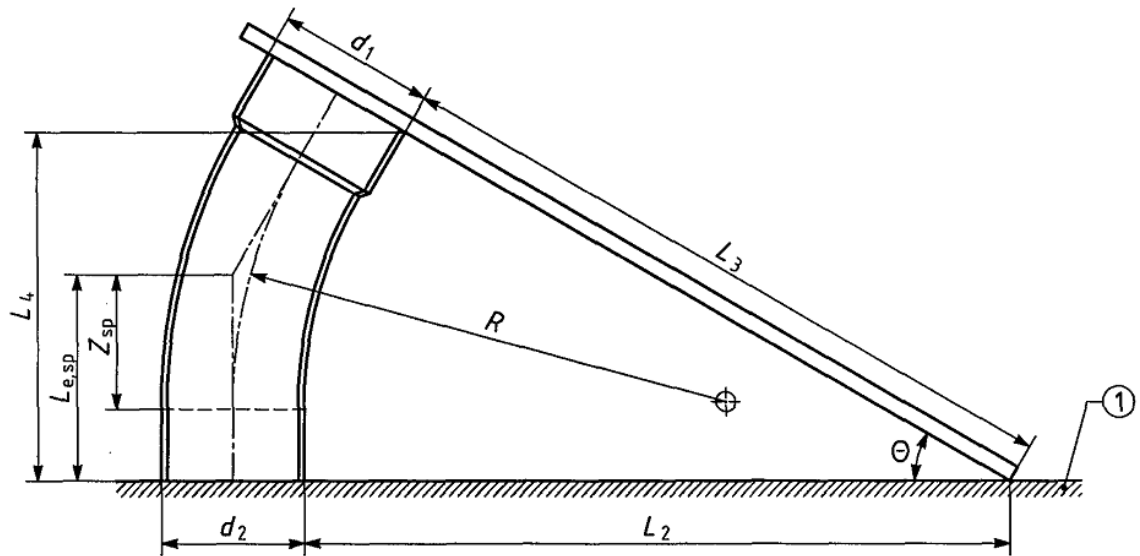
**Key**

1 Reference surface

b) bend with spigoted lower end**Figure 2 — Arrangements for the procedure****6.2.3 Radius of curvature**

NOTE The radius of curvature can only be determined if the straight length of the end of the fittings is given by the manufacturer.

Calculate the radius of curvature using the one of the following equation as applicable:

$$R = \frac{L_{e,sp} - L_{str}}{\tan 0,5\theta}, \text{ for spigoted fitting end;}$$

$$R = \frac{L_{e,so} + L_5 - L_{str}}{\tan 0,5\theta}, \text{ for socketed fitting end;}$$

where:

R is the radius of curvature;

$L_{e,sp}$ is the effective length of the spigoted fitting end;

$L_{e,so}$ is the effective length of the socketed fitting end;

L_{str} is the given straight length of the applicable fitting end;

L_5 is the socket insertion depth (measured or given) as specified in the referring standard;

θ is the fitting angle as determined in 6.2.2 (see Figure 2).

6.3 Branches

6.3.1 General

Select instrument(s) or device(s) and associated procedures so that the accuracy of the result is in accordance with Table 6, unless otherwise specified in the referring standard.

Before starting the measurements, confirm the squareness of the fitting ends using the procedures described in 5.6. If an end is not square to its axis, this shall be taken into consideration in the calculation by referring the calculated result to the most protruding point of the cut end.

6.3.2 Effective length of the main pipe

Using the procedures described in 5.5.2, measure the overall length of the main pipe of the fitting.

Record the larger of the two measurements, rounded in accordance with Table 6, as the measured overall length L_6 of the main pipe (see Figure 3).

Using a device such as a vernier calliper or micrometer depth gauge measure, if applicable, the socket insertion depth, L_5 .

Calculate the effective length, L_{em} , using the following equation:

$$L_{em} = L_6 - L_5, \text{ for a main with one socket,}$$

$$L_{em} = L_6 - 2L_5, \text{ for a main with two sockets,}$$

where:

- L_{em} is the effective length of the main pipe;
- L_5 is the socket insertion depth;
- L_6 is the overall length of the main pipe (see Figure 3).

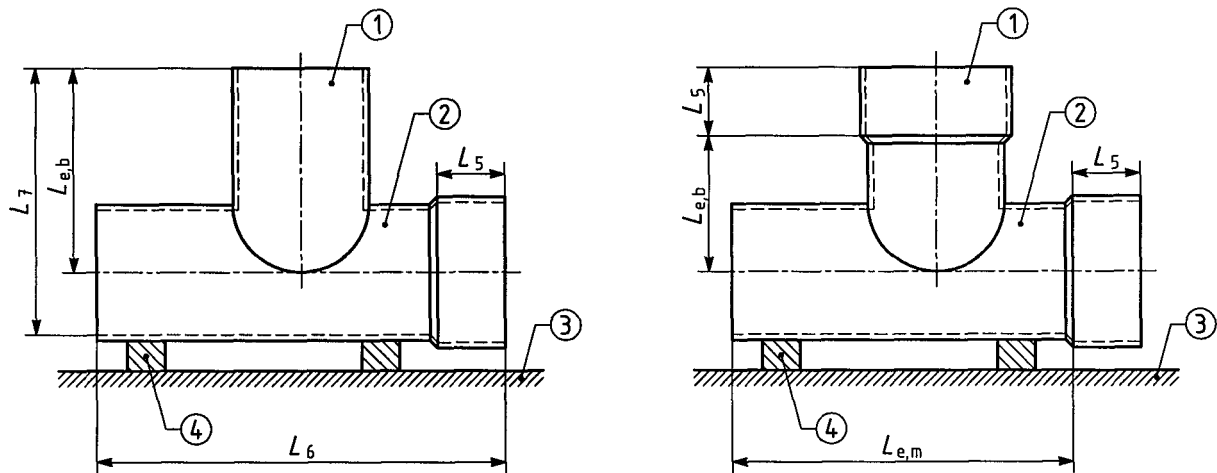

- Key**
- 1 Branch
 - 2 Main pipe
 - 3 Reference surface
 - 4 Packing

Figure 3 — Measurement of the lengths of tee branches

6.3.3 Effective length of a branch pipe

Measure on the inside of the branch, along two lines diametrically opposite to each other and parallel with the axis of the branch pipe, the lengths $L_{7,1}$ and $L_{7,2}$ (see Figure 4) of the branch.

Calculate the average of $L_{7,1}$ and $L_{7,2}$ and record the value obtained, rounded in accordance with Table 6, as the length L_7 (see Figure 4). For a 90° branch only one measurement is needed (see Figure 3).

Using a device such as a vernier calliper or micrometer depth gauge measure, if applicable, the socket insertion depth, L_5 , as specified in the referring standard.

Using the procedure described in 5.3.4, determine the mean inside diameter of the main pipe.

Calculate the branch effective length, $L_{e,b}$, using the applicable equation as follows:

$$L_{e,b} = L_7 - \frac{0,5d_{i,m}}{\sin \theta}, \text{ for a spigot-ended branch pipe;}$$

$$L_{e,b} = L_7 - \frac{0,5d_{i,m}}{\sin \theta} - L_5, \text{ for a socket-ended branch pipe,}$$

where:

$d_{i,m}$ is the mean inside diameter of the main pipe of the branch;

$L_{e,b}$ is the branch effective length;

L_5 is the socket insertion depth;

L_7 is the average of the measured lengths $L_{7,1}$ and $L_{7,2}$ (see Figure 4), i.e. $L_7 = 0,5(L_{7,1} + L_{7,2})$;

θ is the fitting angle as determined in 6.2.2.

NOTE In case of a 90° branch $\sin \theta = 1$.

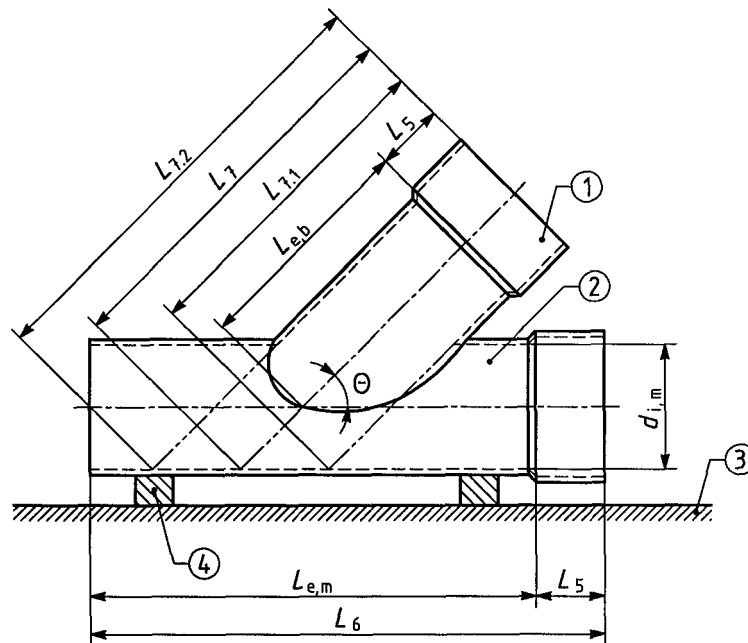

Key

- 1 Branch
- 2 Main pipe
- 3 Reference surface
- 4 Packing

Figure 4 — Measurement of effective length of branches with angles other than 90°

6.4 Reducers

6.4.1 General

Select instrument(s) or device(s) used for measuring the following dimensions so that the accuracy of the result is in accordance with Table 6, unless otherwise specified in the referring standard.

Before starting the measurements, confirm the squareness of the fitting ends using the procedures described in 5.6. If an end is not square to its axis, this shall be taken into consideration in the calculation by referring the calculated result of the most protruding point of the cut end.

6.4.2 Effective length

Place the reducer on its larger end on a surface plate.

At two diametrically opposite locations and parallel with the axis, measure the lengths $L_{8,1}$ and $L_{8,2}$ (see Figure 5). Calculate the average of the two measurements, then round in accordance with Table 5 and record the result as the length L_8 .

Of the socket of the larger diameter end, if any, determine the average of the socket insertion depth through measurements taken at equally spaced locations around the circumference using a device such as a vernier calliper or micrometer depth gauge. Record the average socket insertion depth as $L_{5,L}$.

Of the socket of the smallest diameter end, if any, determine the average of the socket insertion depth through measurements taken at equally spaced locations around the circumference using a device such as a vernier calliper or micrometer depth gauge. Record the average socket insertion depth as $L_{5,S}$.

Calculate the effective length, $L_{e,r}$, using the following equation:

$$L_{e,r} = L_8 - L_{5,L} - L_{5,S}$$

where:

- $L_{e,r}$ is the effective length of the reducer;
- L_8 is the overall length, i.e. the average of the two measured lengths;
- $L_{5,L}$ is the insertion depth of the socket, if any, at the larger diameter end;
- $L_{5,S}$ is the insertion depth of the socket, if any, at the smaller diameter end.

6.4.3 Length of the tapered section

Place the reducer on its larger end on a reference surface.

Determine the overall length of the reducer, L_8 , in accordance with 6.4.2.

Measure in accordance with 5.5.2 the lengths $L_{str,sp}$ and $L_{str,so}$ of the two cylindrical sections (see Figure 5) and record the measurements after rounding in accordance with Table 6.

Using the following equation, calculate the length of the tapered section L_t and record the value obtained:

$$L_t = L_8 - L_{str,sp} - L_{str,so}$$

where:

- L_8 is the overall length of the reducer;
- $L_{str,so}$ and $L_{str,sp}$ are the lengths of the straight sections.

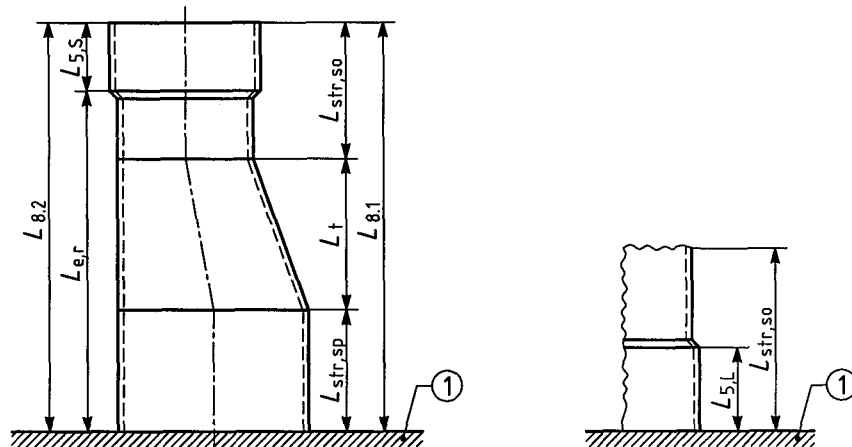

Key
 1 Reference surface

Figure 5 — Measurement of the effective length of a reducer

7 Flanges, loose flanges and collar

7.1 General

Select instrument(s) or device(s) and associated procedures used for measuring the following dimensions so that the accuracy of the result is in accordance with Table 6, unless otherwise specified.

NOTE The dimensions subject to measurement or calculation are given in Figure 6 and/or Figure 7, as applicable.

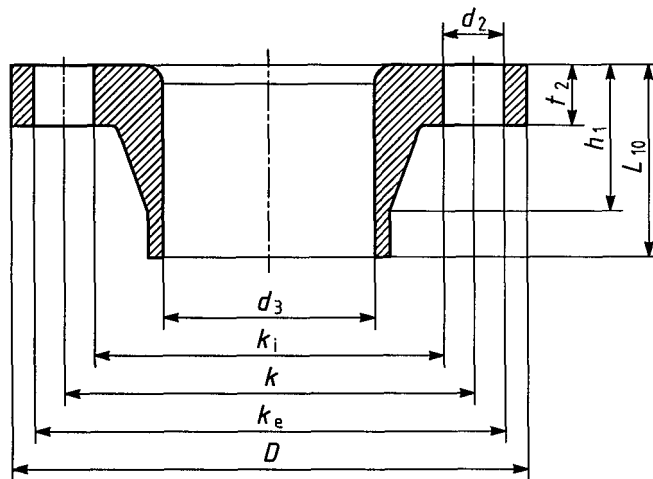
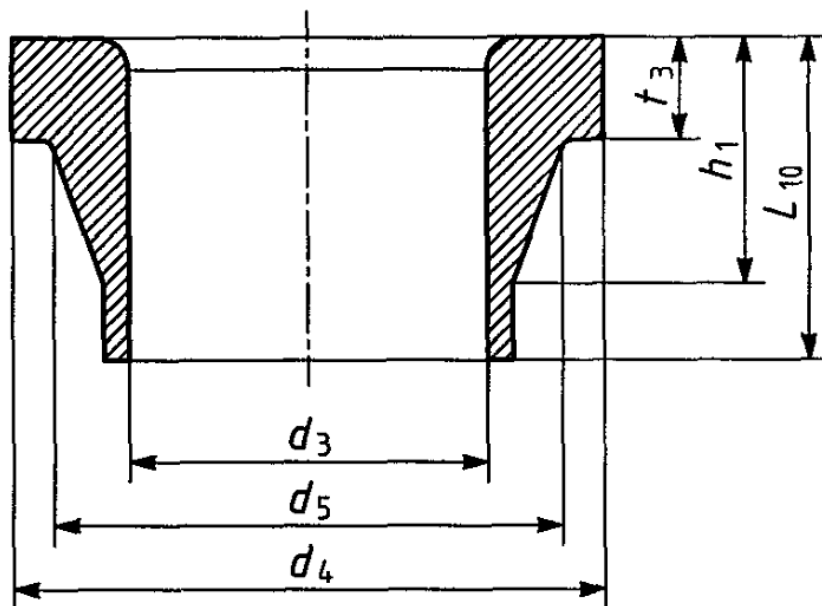
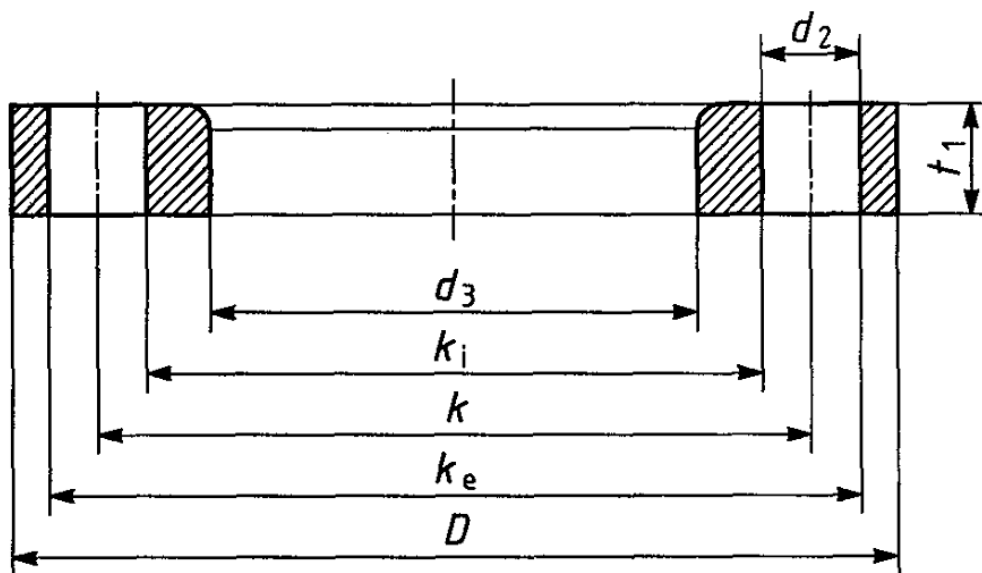

Figure 6 — Flange dimensions



a) loose flange



b) collar

Figure 7 — Dimensions of collars and loose flanges

7.2 Outside diameter of the flange, loose flange and collar

Using the procedures described in 5.3.3, determine the mean outside diameter, D , of the flange [see Figure 6 and Figure 7a)].

7.3 Bore diameter of the flange or collar

Using the procedures described in 5.3.4, determine the mean bore diameter, d_3 , of the flange or collar [see Figure 6 and Figure 7b)] or the mean bore diameter d_3 of the loose flange [see Figure 7a)].

7.4 Bolt hole diameter

Using the procedures described in 5.3.4, determine and record the diameter of each bolt hole, d_4 [see Figure 6 and Figure 7a)].

7.5 Bolt hole distribution

If the bolt hole diameters determined in accordance with 7.4 are all of the same size, then with an accuracy in accordance with Table 6 measure and record each linear distance, c_1 , between adjacent bolt hole edges.

If the bolt hole diameters determined in accordance with 7.4 differ in size, then with an accuracy in accordance with Table 6 determine and record the linear distance, c_2 , between the bolt hole centres e.g. by measuring the linear distance, c_1 , between the adjacent bolt hole edges and adding half the diameter of each involved bolt hole determined in accordance with 7.4.

7.6 Concentricity of bolt circle diameter

7.6.1 If the bolt hole diameters determined in accordance with 7.4 are all of the same size, then with an accuracy in accordance with Table 6 measure and record each linear distance, b_1 , between the bolt holes and the bore.

In case of a blind flange measure and record each linear distance, b_2 , between the bolt holes and the outside diameter of the flange.

7.6.2 If the bolt hole diameters determined in accordance with 7.4 differ in size, then with an accuracy in accordance with Table 6 determine and record each linear distance, b_3 , between the bolt hole centres and the bore, e.g. by measuring the distance, b_1 , and adding half the diameter of the involved bolt hole determined in accordance with 7.4.

In case of a blind flange determine and record each linear distance, b_4 , between the bolt hole centres and the outside diameter of the flange following the same principle.

7.7 Pitch circle diameter

With an accuracy in accordance with Table 6 determine the mean diameter of the internal bolt hole edges, k_i , or the mean diameter of the external bolt hole edges, k_e [see Figure 6 and Figure 7a)], by taking $n/2$ measurements, where n is the number of bolt holes, and calculate the mean value.

Calculate the pitch circle diameter, k , using one of the following equations:

$$k = k_i + d_4$$

or,

$$k = k_e - d_4$$

where d_4 is the hole size determined in accordance with 7.4 or the average of the hole sizes in case of differing hole sizes, e.g. $d_4 = 0,5(d_{4,1} + d_{4,2})$ in case of two differing sizes.

Round the calculated average diameter in accordance with Table 2 and record the result obtained as the pitch circle diameter k .

7.8 Shoulder diameter of flange and collar

Using the procedures described in 5.3.1, 5.3.2 and 5.3.3, determine the maximum and minimum shoulder diameter of the collar and the mean shoulder diameter, d_5 [see Figure 7b)].

7.9 Flange and collar thickness

Using a device conforming to 5.2.1 and the procedures described in 5.2.3, determine the mean thickness, t_1 , t_2 or t_3 , as applicable, of the flange or collar [see Figure 6 and Figure 7b)].

7.10 Length of the flange and collar

Place the flange on a reference surface and measure in accordance with 5.5.2 the length [see h_1 and L_{10} in Figure 6 and Figure 7b)] at least at four positions equally spaced around the flange.

Calculate the average of the results obtained, round in accordance with Table 5 and record this calculated average as the length h_1 or the overall length L_{10} of the flange or collar.

8 Other measurements

Select the instrument(s) or device(s) and associated procedures used for measuring dimensions not covered by 5.2 to Clause 7, so that the accuracy of the result is in accordance with Table 6, unless otherwise specified by the referring standard.

To determine dimensions not covered by 5.2 to Clause 7 in accordance with 5.1 use the above prescribed device and record the result(s) obtained after rounding in accordance with Table 6.

Bibliography

- [1] ISO 3534-1, *Statistics — Vocabulary and symbols — Part 1: Probability and general statistical terms*

ICS 23.040.20

Price based on 19 pages