

Puser 182-150

UB/TIB Hannover

R N 864

INTERNATIONAL STANDARD

ISO 3105

Second edition
1994-12-01

Glass capillary kinematic viscometers — Specifications and operating instructions

*Viscosimètres à capillaire, en verre, pour viscosité cinématique —
Spécifications et mode d'emploi*



Reference number
ISO 3105:1994(E)

Contents

	Page
1 Scope	1
2 Normative reference	1
3 Symbols for viscometer parts	1
4 Viscometer materials and manufacture	2
5 Viscometer holder and alignment	2
6 Calibration of viscometers	2
7 Kinematic viscosity calculation	4

Annexes

A Modified Ostwald viscometers	6
B Suspended-level viscometers	22
C Reverse-flow viscometers	42

© ISO 1994

All rights reserved. Unless otherwise specified, no part of this publication may be reproduced or utilized in any form or by any means, electronic or mechanical, including photocopying and microfilm, without permission in writing from the publisher.

International Organization for Standardization
Case Postale 56 • CH-1211 Genève 20 • Switzerland

Printed in Switzerland

Foreword

ISO (the International Organization for Standardization) is a worldwide federation of national standards bodies (ISO member bodies). The work of preparing International Standards is normally carried out through ISO technical committees. Each member body interested in a subject for which a technical committee has been established has the right to be represented on that committee. International organizations, governmental and non-governmental, in liaison with ISO, also take part in the work. ISO collaborates closely with the International Electrotechnical Commission (IEC) on all matters of electrotechnical standardization.

Draft International Standards adopted by the technical committees are circulated to the member bodies for voting. Publication as an International Standard requires approval by at least 75 % of the member bodies casting a vote.

International Standard ISO 3105 was prepared by Technical Committee ISO/TC 28, *Petroleum products and lubricants*.

This second edition cancels and replaces the first edition (ISO 3105:1976, corrected and reprinted 1984), which has been technically revised.

Annexes A, B and C form an integral part of this International Standard.

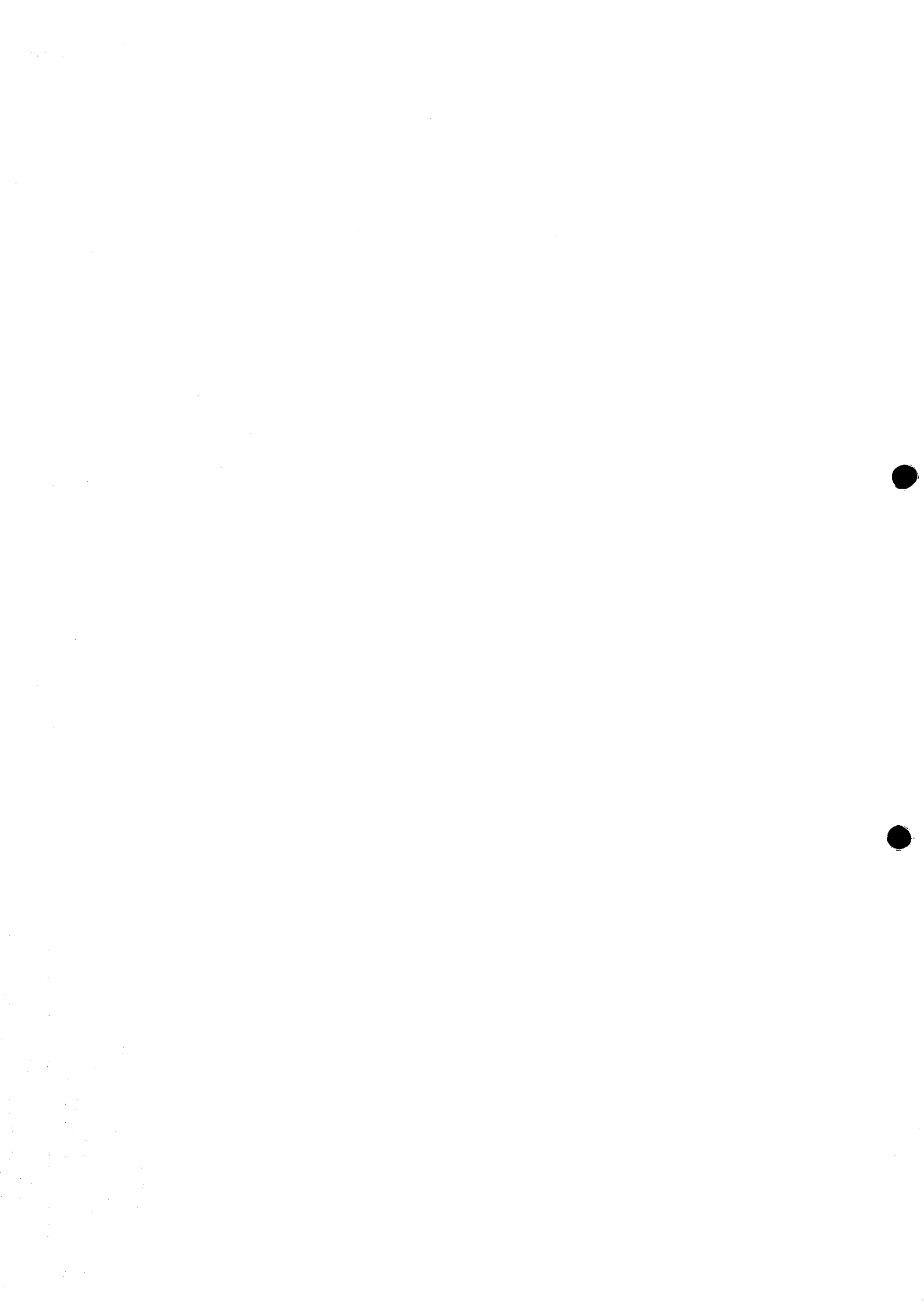

Glass capillary kinematic viscometers — Specifications and operating instructions

WARNING — The use of this International Standard may involve hazardous materials, operations and equipment. This International Standard does not purport to address all of the safety problems associated with its use. It is the responsibility of the user of this International Standard to establish appropriate safety and health practices and determine the applicability of regulatory limitations prior to use.

1 Scope

This International Standard gives specifications and operating instructions for glass capillary viscometers widely used for the determination of kinematic viscosity of petroleum products by the procedure described in ISO 3104. The calibration of these viscometers is also described.

The types of viscometers described are modified Ostwald viscometers (annex A), suspended-level viscometers (annex B) and reverse-flow viscometers (annex C). Other viscometers of the glass capillary type which are capable of measuring kinematic viscosity within the limits of precision given in ISO 3104 may be used.

2 Normative reference

The following standard contains provisions which, through reference in this text, constitute provisions of this International Standard. At the time of publication, the edition indicated was valid. All standards are subject to revision, and parties to agreements based on this International Standard are encouraged to investigate the possibility of applying the most recent edition of the standard indicated below. Members of IEC and ISO maintain registers of currently valid International Standards.

ISO 3104:1994, *Petroleum products — Transparent and opaque liquids — Determination of kinematic viscosity and calculation of dynamic viscosity.*

3 Symbols for viscometer parts

Letters are used to designate specific parts of each viscometer described in the annexes. These letters are also used in the text of this International Standard when reference to the viscometers is given. The more frequently used letters on the figures in the annexes are as follows:

A	Lower reservoir
B	Suspended level bulb
C and J	Timing bulbs
D	Upper reservoir
E, F and I	Timing marks
G and H	Filling marks
K	Overflow tube
L	Mounting tube
M	Lower vent tube
N	Upper vent tube
P	Connecting tube
R	Working capillary

4 Viscometer materials and manufacture

4.1 Fully annealed, low-expansion borosilicate glass shall be used for the construction of all viscometers. The size number, serial number and manufacturer's designation shall be permanently marked on each viscometer. All timing marks shall be etched and filled with an opaque colour, or otherwise made a permanent part of the viscometer.

4.2 With the exception of the FitzSimons and Atlantic viscometers, all viscometers shall be designed to fit through a 51 mm hole in the lid of a constant-temperature bath having a liquid depth of at least 280 mm; it is assumed that the surface of the bath liquid will be not more than 45 mm from the top of the bath lid.

NOTE 1 For certain constant-temperature baths, especially at low or high temperatures, it may be necessary to construct the viscometers with the uppermost tubes longer than shown in the annexes to ensure adequate immersion in the constant-temperature bath. Viscometers so modified can be used to measure kinematic viscosity within the precision of the test method. The lengths of tubes and bulbs shown in the figures should be maintained within $\pm 10\%$ or ± 10 mm, whichever is less, such that the calibration constant of the viscometer does not vary by more than $\pm 15\%$ from the nominal value.

5 Viscometer holder and alignment

All viscometers which have the upper meniscus directly above the lower meniscus (Cannon-Fenske routine in annex A and all viscometers in annex B) shall be mounted in a constant-temperature bath with tube L held within 1° of the vertical, as observed with a plumb bob or other equally accurate inspection means.

NOTE 2 A number of commercially available holders are so designed that the tube L is held perpendicular to the lid of a constant-temperature bath; nevertheless, the viscometer should be tested with a plumb line in order to ensure that the tube L is in a vertical position.

Those viscometers whose upper meniscus is offset from directly above the lower meniscus (all other viscometers in annex A and all viscometers in annex C) shall be mounted in a constant-temperature bath with tube L held within $0,3^\circ$ of the vertical.

NOTE 3 Round metal tops, designed to fit above a 51 mm hole in the lid of the bath, are frequently cemented on to Zeitfuchs, Zeitfuchs cross-arm and Lantz-Zeitfuchs viscometers which then are permanently mounted on the lid of the bath. Also a rectangular metal top,

25 mm \times 59 mm, is often cemented on to Zeitfuchs cross-arm and Zeitfuchs viscometers. Viscometers fitted with metal tops should be set vertically in the constant-temperature bath with the aid of a plumb line.

In each figure, the numbers which follow the tube designation indicate the outside tube diameter, in millimetres. It is important to maintain these diameters and the designated spacing to ensure that holders will be interchangeable.

6 Calibration of viscometers

6.1 Procedures

Calibrate the kinematic glass capillary viscometers covered by this International Standard using the procedures specified in annexes A to C.

6.2 Reference viscometers

6.2.1 Select a clear petroleum oil, free from solid particles and possessing Newtonian flow characteristics, with a kinematic viscosity within the range of both the reference viscometer and the viscometer to be calibrated. The minimum flow time shall be greater than that specified in the appropriate table of the annex in both the reference viscometer and the viscometer which is to be calibrated in order that the kinetic energy correction (see 7.1) may be less than 0,2 %.

6.2.2 Select a calibrated viscometer of known viscometer constant C_1 .

NOTE 4 This viscometer may be a reference viscometer (driving head at least 400 mm) that has been calibrated by the step-up procedure using viscometers of successively larger diameters, starting with distilled water as the basic kinematic viscosity standard, or a routine viscometer of the same type that has been calibrated by comparison with a reference viscometer.

The calibration of the reference viscometer should only be carried out by a reputable laboratory meeting the requirements of, for example, ISO Guide 25.

Mount the calibrated viscometer together with the viscometer to be calibrated in the same bath and determine the flow times of the petroleum oil in accordance with ISO 3104.

6.2.3 Calculate the viscometer constant C_1 as follows:

$$C_1 = (t_2 \times C_2) / t_1 \quad \dots (1)$$

where

- C_1 is the constant of the viscometer being calibrated;
- t_1 is the flow time, to the nearest 0,1 s, in the viscometer being calibrated;
- C_2 is the constant of the calibrated viscometer;
- t_2 is the flow time, to the nearest 0,1 s, in the calibrated viscometer.

6.2.4 Repeat 6.2.1 to 6.2.3 with a second oil whose flow times are at least 50 % longer than the first oil. If the two values of C_1 differ by less than 0,2 % for those viscometers listed in annexes A and B and less than 0,3 % for those viscometers listed in annex C, use the average as the viscometer constant for the viscometer being calibrated. If the constants differ by more than this value, repeat the procedure, taking care to examine all possible sources of errors.

6.2.5 The calibration constant, C , is dependent upon the gravitational acceleration at the place of calibration and this must, therefore, be supplied by the standardization laboratory, together with the instrument constant. Where the acceleration of gravity, g , differs by more than 0,1 %, correct the calibration constant as follows:

$$C_2 = (g_2/g_1)C_1 \quad \dots (2)$$

where the subscripts 1 and 2 indicate respectively the standardization laboratory and the testing laboratory.

6.3 Viscosity reference standards

Kinematic viscosity reference standards¹⁾ are available having the approximate kinematic viscosity shown in table 1. Certified kinematic viscosity values are established by cooperative tests and are supplied with each delivery.

6.3.1 Select from table 1 a viscosity reference standard with a kinematic viscosity at the calibration temperature within the kinematic viscosity range of the viscometer to be calibrated and a minimum flow time greater than that specified in the appropriate table of the annex. Determine the flow time, to the nearest 0,1 s, in accordance with ISO 3104, and calculate the viscometer constant, C , as follows:

$$C = \nu/t \quad \dots (3)$$

where

ν is the kinematic viscosity, in millimetres squared per second, for the reference standard liquid;

t is the flow time, in seconds.

Table 1 — Typical viscosity reference standards

Designation of viscosity reference standard	Approximate kinematic viscosity					
	mm ² /s					
	°C					
	- 40	20	25	40	50	100
3	80	4,6	4,0	2,9	—	1,2
6	—	11	8,9	5,7	—	1,8
20	—	44	34	18	—	3,9
60	—	170	120	54	—	7,2
200	—	640	450	180	—	17
600	—	2 400	1 600	520	280	32
2 000	—	8 700	5 600	1 700	—	75
8 000	—	37 000	23 000	6 700	—	—
30 000	—	—	81 000	23 000	11 000	—

1) Viscosity reference standards are available in certain countries from national laboratories or other authorized sources. These reference liquids cover the range of all viscometers described in this International Standard.

6.3.2 Repeat with a second reference standard whose flow times are at least 50 % longer than the first reference standard. If the two values of C differ by less than 0,2 % for those viscometers listed in annexes A and B and less than 0,3 % for those viscometers listed in annex C, use the average as the viscometer constant for the viscometer being calibrated. If the constants differ by more than this value, repeat the procedure, taking care to examine all possible sources of errors.

6.4 Expression of viscometer constant

Report the viscometer constant, C , to the nearest 0,1 % of the determined value. This generally means four significant figures from 1×10^N to $6,999 \times 10^N$ and three significant figures from 7×10^N to $9,99 \times 10^N$.

7 Kinematic viscosity calculation

7.1 Basic formula

In principle, the calculation of kinematic viscosity is related to the dimensions of the viscometer according to the Hagen-Poiseuille law as follows:

$$\nu = (10^6 \pi g D^4 H t / 128 V L) - E/t^2 \quad \dots (4)$$

where

- ν is the kinematic viscosity, in millimetres squared per second;
- g is the acceleration due to gravity, in metres per second squared;
- D is the diameter of the capillary, in metres;
- L is the length of the capillary, in metres;
- H is the average distance between the upper and lower menisci (average driving head), in metres;
- V is the timed volume of liquids passing through the capillary, in metres cubed (approximately the volume of the timing bulb);
- E is the kinetic energy factor, in square millimetre seconds;
- t is the flow time, in seconds.

If the viscometer is selected so that the minimum flow time shown in the tables of annexes A to C is exceeded, the kinetic energy term, E/t^2 , becomes insignificant and equation (4) may be simplified by

grouping the nonvariable terms into a constant, C , as follows:

$$\nu = Ct \quad \dots (5)$$

7.2 Kinetic energy correction

The viscometers described in the annexes A to C are designed such that the kinetic energy correction term, E/t^2 , is negligible if the flow time is more than 200 s. In the case of several sizes of viscometers for the measurement of low kinematic viscosity liquids, a minimum flow time greater than 200 s is required in order that the kinetic energy correction term, E/t^2 , shall be negligible. The minimum flow times required are given in footnotes to the appropriate tables of viscometer dimensions in the annexes A to C.

For viscometers whose constants C are $0,01 \text{ mm}^2/\text{s}^2$ or less, the kinetic energy correction may be significant if the minimum 200 s flow time is not observed.

7.3 Maximum flow time

A limit of 1 000 s has been set arbitrarily for convenience as the recommended maximum flow time for the viscometers covered by this International Standard. Longer flow times may be used.

7.4 Surface tension correction

If the two menisci have different average diameters during the flow time and if the surface tension of the sample differs substantially from the calibrating liquid, a surface tension correction is necessary. The corrected constant, C_{corr} , is given approximately as follows:

$$C_{\text{corr}} = C[1 + (2/gH)(1/r_u - 1/r_l)(\gamma_c/\rho_c - \gamma_t/\rho_t)] \quad \dots (6)$$

where

- g is the acceleration due to gravity, in metres per second squared;
- H is the average length of the driving head, in metres;
- r_u is the average radius of the upper meniscus, in metres;
- r_l is the average radius of the lower meniscus, in metres;
- γ is the surface tension, in newtons per metre;

ρ is the density, in kilograms per cubic metre.

Subscripts c and t relate to values obtained with the calibrating liquid and the test portion, respectively.

While this correction applies to all viscometers, a number of viscometers are designed to minimize the surface tension correction. The greatest correction normally encountered is with a viscometer calibrated with water and used for oils. Generally, viscometers are calibrated and used with hydrocarbons whose surface tensions are close enough for these corrections to be insignificant.

7.5 Effect of temperature

7.5.1 The viscometer constant, C , is independent of temperature for all those viscometers which have the volume of sample adjusted at bath temperature and for all suspended-level viscometers.

7.5.2 The following viscometers, which have a fixed volume charged at ambient temperature, have a viscometer constant, C , which varies with temperature: Cannon-Fenske routine, Pinkevitch, Cannon-Manning semimicro, Cannon-Fenske opaque.

7.5.2.1 The following equation can be used to calculate the viscometer constant at temperatures other than the calibration temperature for the Cannon-Fenske routine, Pinkevitch and Cannon-Manning semimicro viscometers:

$$C_2 = C_1 \left\{ 1 + [4\ 000V(\rho_2 - \rho_1)] / (\pi D^2 H \rho_2) \right\} \dots (7)$$

where

C_1 is the constant of the viscometer when filled and calibrated at the same temperature;

V is the volume of charge, in millilitres;

D is the average diameter of the meniscus in the lower reservoir for the Cannon-Fenske routine, Pinkevitch and Cannon-Manning semimicro viscometers, and in the upper reservoir of the Cannon-Fenske opaque viscometer, in millimetres;

H is the average length of the driving head, in millimetres;

ρ_1 is the density of the test liquid at the filling temperature, in kilograms per litre [$\text{kg}/(\text{m}^3 \times 10^{-3})$];

ρ_2 is the density of the test liquid at the test temperature, in kilograms per litre [$\text{kg}/(\text{m}^3 \times 10^{-3})$];

7.5.2.2 The temperature dependence of C for the Cannon-Fenske opaque (reverse-flow) viscometer is given as follows:

$$C_2 = C_1 \left\{ 1 - [4\ 000V(\rho_2 - \rho_1)] / (\pi D^2 H \rho_2) \right\} \dots (8)$$

Annex A (normative)

Modified Ostwald viscometers

A.1 General

The following viscometers of the modified Ostwald type for transparent liquids follow the basic design of the Ostwald viscometer, but are modified to ensure a constant volume test portion in the viscometer as described in A.1.1 and A.1.2.

These viscometers are used for the measurement of kinematic viscosities of transparent Newtonian liquids up to 20 000 mm²/s.

For the modified Ostwald viscometers, detailed drawings, size designations, nominal constants, kinematic viscosity ranges, capillary diameters and bulb volumes for each viscometer are shown in figures A.1 to A.7.

A.1.1 Viscometers having constant volume at filling temperature:

- Cannon-Fenske routine viscometer
- Cannon-Manning semimicro viscometer
- Pinkevitch viscometer

A.1.2 Viscometers having constant volume at test temperature:

- Zeitfuchs viscometer
- SIL viscometer
- BS/U-tube viscometer
- BS/U-tube miniature viscometer

A.2 Operating instructions

A standard operating procedure applicable to all glass capillary kinematic viscometers is contained in ISO 3104. Operating instructions for the modified Ostwald viscometers are outlined in A.2.1 to A.2.6

with emphasis on procedures that are specific to this group of viscometers.

A.2.1 Select a clean, dry calibrated viscometer which will give a flow-time greater than 200 s or the minimum shown in the appropriate table of dimensions, whichever is greater.

A.2.2 Charge the viscometer in the manner dictated by the design of the instrument, the operation being in conformity with that employed when the instrument was calibrated. If the sample is thought to contain fibres or solid particles, filter through a 75 µm screen during charging.

A.2.2.1 To charge the Cannon-Fenske routine, Cannon-Manning semimicro and Pinkevitch viscometer, invert the viscometer and apply suction to tube L (the Pinkevitch viscometer has a side arm O to which vacuum is applied, with the finger on tube L being used to control the liquid flow) with tube N immersed in the liquid sample. Draw the sample to timing mark F for the Cannon-Fenske routine and Pinkevitch viscometers and to filling mark G for the Cannon-Manning semimicro viscometer. Mount the viscometer upright in the constant-temperature bath, keeping tube L vertical.

A.2.2.2 Mount the Zeitfuchs viscometer in the constant-temperature bath, keeping tube L vertical. Pour the sample through tube L to filling mark G. Allow 15 min for the sample to attain bath temperature and become free of air bubbles. Attach the vacuum line with stopcock and trap to tube K. Slowly draw the sample into timing bulb C by partially opening the stopcock in the vacuum line and partially closing tube N with the finger. Allow the excess liquid to flow into bulb D and through tube K into the trap in the vacuum line. When the liquid in tube L reaches a point 2 mm to 5 mm above filling mark H, hold it at this point by alternately closing and opening tube N to the atmosphere with the finger for the appropriate time given in table A.1 to permit the sample to drain from the walls of tube L.

Table A.1 — Drainage time for various kinematic viscosity ranges in the Zeiffuchs viscometer

Kinematic viscosity of sample, ν mm ² /s	Drainage time s
$\nu < 10$	10 to 20
$10 \leq \nu < 100$	40 to 60
$100 \leq \nu < 1\ 000$	100 to 120
$1\ 000 < \nu$	180 to 200

Adjust the working volume by drawing the meniscus at the bottom of the column of the liquid exactly to filling mark H, making sure that the sample completely fills the viscometer between mark H and the tip of the overflow in bulb D; after this final adjustment of the working volume, remove the finger and close or remove the connection to the vacuum source. The final adjustment may be more conveniently made by disconnecting the vacuum and applying pressure to the mounting tube L by use of a rubber bulb.

A.2.2.3 Charge the SIL viscometer by tilting it about 30° from the vertical, with bulb A below capillary R. Introduce enough of the sample into tube L for bulb A to fill completely and overflow into the gallery. Return the viscometer to the vertical position and mount it in the constant-temperature bath so that tube L is vertical. The quantity of sample charged should be such that the level in the lower reservoir is 3 mm to 14 mm above opening S. The sample will rise in capillary R somewhat higher than opening S. After the temperature equilibrium has been reached, remove any excess sample from the gallery by suction applied to tube K.

A.2.2.4 Mount the BS/U-tube or BS/U/M miniature viscometer in the constant-temperature bath, keeping tube L vertical. Using a long pipette to minimize any wetting of tube L above filling mark G, fill bulb A with a slight excess of the sample. After allowing the sample to attain the bath temperature, adjust the vol-

ume of the sample to bring the liquid level within 0,2 mm of filling mark G by withdrawing the sample with a pipette.

A.2.3 Allow the charged viscometer to remain in the bath long enough to reach the test temperature. Because this time will vary for different instruments, for different temperatures and for different kinematic viscosities, establish a safe equilibrium time by trial (30 min should be sufficient except for the highest kinematic viscosities). One bath is often used to accommodate several viscometers. Never add or withdraw a viscometer while any other viscometer is in use for measuring a flow time.

A.2.4 Use vacuum (or pressure if the sample contains volatile constituents) to draw the sample through bulb C to approximately 5 mm above upper timing mark E. Release the vacuum, and allow the sample to flow by gravity.

A.2.5 Measure, to the nearest 0,1 s, the time required for the leading edge of the meniscus to pass from timing mark E to timing mark F. If this flow time is less than the minimum flow time specified for the viscometer, select a viscometer with a smaller diameter capillary and repeat steps A.2.2 through A.2.5.

A.2.6 Repeat steps A.2.4 and A.2.5, making a duplicate measurement of flow time. If the two measurements agree within the determinability given in ISO 3104 for the petroleum product being measured, use the average for calculating the kinematic viscosity.

A.2.7 Clean the viscometer thoroughly by several rinsings with an appropriate solvent completely miscible with the sample, followed by rinsing with a completely volatile solvent. Dry the viscometer by passing a slow stream of filtered, dry air through the viscometer for 2 min, or until the last trace of solvent is removed. The use of alkaline cleaning solutions is not recommended, as changes in the viscometer calibration may occur.

Dimensions in millimetres
For tolerances on lengths, see 4.2

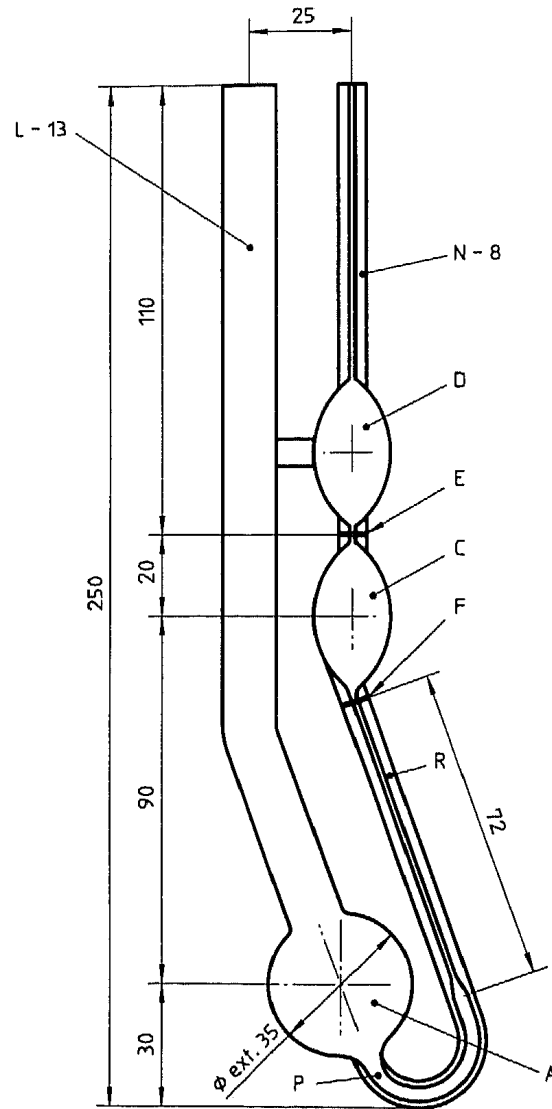

NOTE — For size 25 only, the capillary N extends straight through bulbs D and C to about 10 mm below bulb C; the timing mark F encircles this capillary.

Figure A.1 — Cannon-Fenske routine viscometer

Table A.2 — Cannon-Fenske routine — Dimensions and kinematic viscosity ranges

Size No.	Nominal viscometer constant (mm ² /s)/s	Kinematic viscosity range mm ² /s	Inside diameter of tube R mm (± 2 %)	Inside diameter of tubes N, E and P mm (± 2 %)	Bulb volume ml (± 5 %)	
					D	C
25	0,002	0,5 ¹⁾ to 2	0,30	2,6 to 3,0	3,1	1,6
50	0,004	0,8 to 4	0,44	2,6 to 3,0	3,1	3,1
75	0,008	1,6 to 8	0,54	2,6 to 3,2	3,1	3,1
100	0,015	3 to 15	0,63	2,8 to 3,6	3,1	3,1
150	0,035	7 to 35	0,78	2,8 to 3,6	3,1	3,1
200	0,1	20 to 100	1,01	2,8 to 3,6	3,1	3,1
300	0,25	50 to 250	1,27	2,8 to 3,6	3,1	3,1
350	0,5	100 to 500	1,52	3,0 to 3,8	3,1	3,1
400	1,2	240 to 1 200	1,92	3,0 to 3,8	3,1	3,1
450	2,5	500 to 2 500	2,35	3,5 to 4,2	3,1	3,1
500	8	1 600 to 8 000	3,20	3,7 to 4,2	3,1	3,1
600	20	4 000 to 20 000	4,20	4,4 to 5,0	4,3	3,1

1) 250 s minimum flow time; 200 s minimum flow time for all other sizes.

Dimensions in millimetres
For tolerances on lengths, see 4.2

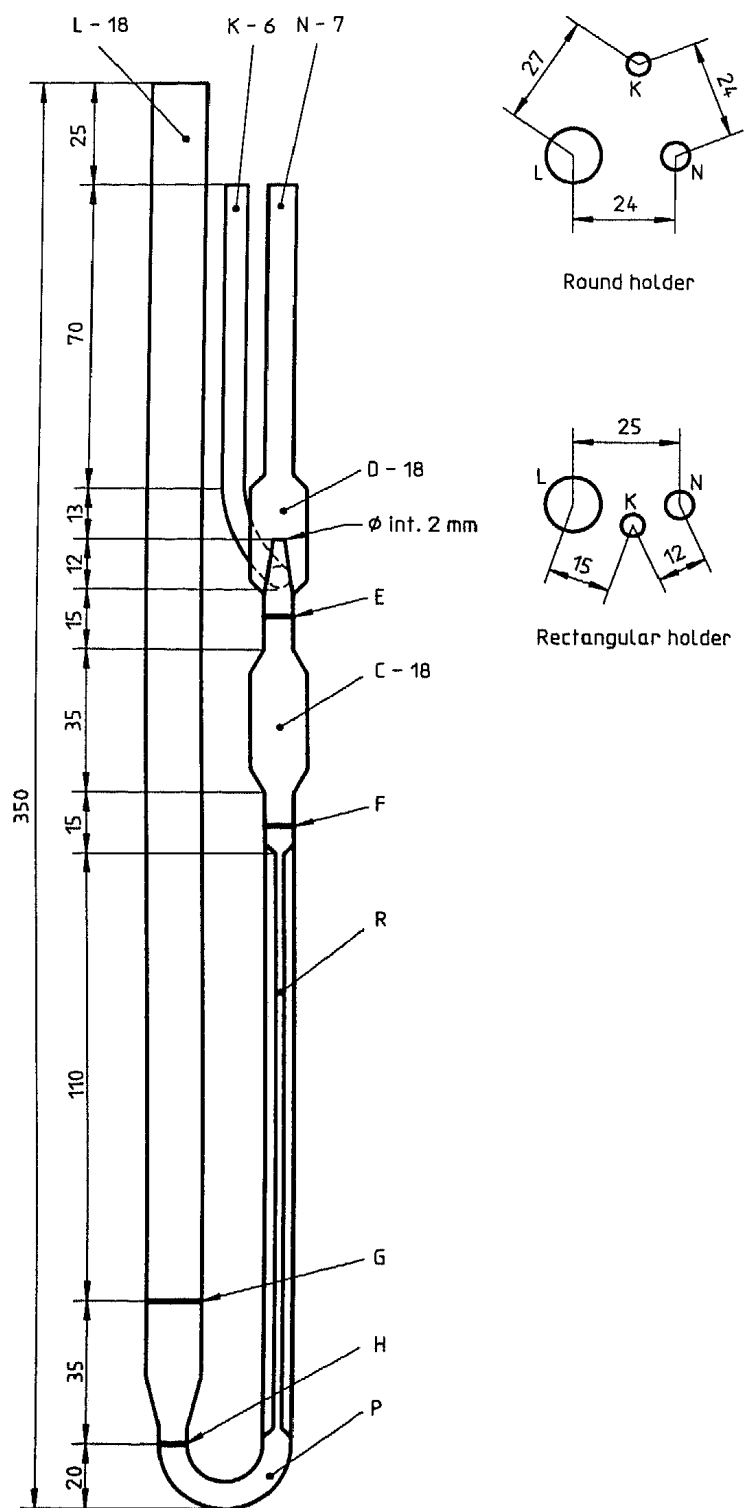

Figure A.2 — Zeitfuchs viscometer

Table A.3 — Zeitfuchs — Dimensions and kinematic viscosity ranges

Size No.	Nominal viscometer constant (mm ² /s)/s	Kinematic viscosity range ¹⁾ mm ² /s	Inside diameter of tube R mm (± 2 %)	Inside diameter of tubes P, E and F mm	Volume of bulb C ml (± 5 %)
1	0,003	0,6 to 3	0,42	3,8 to 4,2	3,0
2	0,01	2 to 10	0,59	3,8 to 4,2	4,0
3	0,03	6 to 30	0,78	3,8 to 4,2	4,0
4	0,1	20 to 100	1,16	3,8 to 4,2	5,0
5	0,3	60 to 300	1,54	3,8 to 4,2	5,0
6	1,0	200 to 1 000	2,08	3,8 to 4,2	5,0
7	3,0	600 to 3 000	2,76	3,8 to 4,2	5,0

1) 200 s minimum flow time for all sizes.

Dimensions in millimetres
For tolerances on lengths, see 4.2

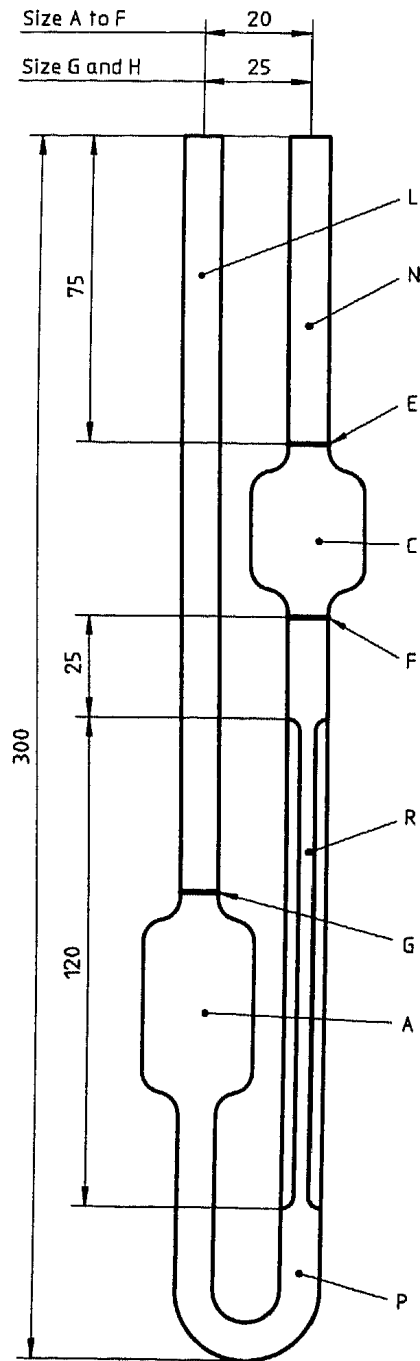

Figure A.3 — BS/U-tube viscometer

Table A.4 — BS/U-tube — Dimensions and kinematic viscosity ranges

Size No.	Nominal viscometer constant (mm ² /s)/s	Kinematic viscosity range mm ² /s	Inside diameter of tube R mm (± 2 %)	Outside diameter of tubes ¹⁾ mm		Volume of bulb C ml (± 5 %)	Vertical distance F to G mm	Outside diameter of bulbs A and C mm
				L and P	N			
A	0,003	0,9 ²⁾ to 3	0,50	8 to 9	6 to 7	5,0	91 ± 4	21 to 23
B	0,01	2,0 to 10	0,71	8 to 9	6 to 7	5,0	87 ± 4	21 to 23
C	0,03	6 to 30	0,88	8 to 9	6 to 7	5,0	83 ± 4	21 to 23
D	0,1	20 to 100	1,40	9 to 10	7 to 8	10,0	78 ± 4	25 to 27
E	0,3	60 to 300	2,00	9 to 10	7 to 8	10,0	73 ± 4	25 to 27
F	1,0	200 to 1 000	2,50	9 to 10	7 to 8	10,0	70 ± 4	25 to 27
G	3,0	600 to 3 000	4,00	10 to 11	9 to 10	20,0	60 ± 3	32 to 35
H	10,0	2 000 to 10 000	6,10	10 to 11	9 to 10	20,0	50 ± 3	32 to 35

1) Use 1 mm to 1,25 mm wall tubing for N, P and L.

2) 300 s minimum flow time; 200 s minimum flow time for all other sizes.

Dimensions in millimetres
For tolerances on lengths, see 4.2

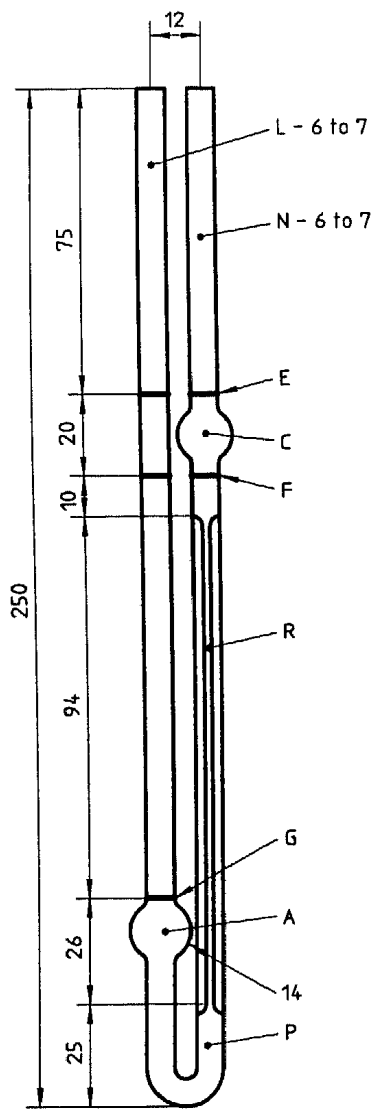

Figure A.4 — BS/U/M miniature viscometer

Table A.5 — BS/U/M — Dimensions and kinematic viscosity ranges

Size No.	Nominal viscometer constant (mm ² /s)/s	Kinematic viscosity range ¹⁾ mm ² /s	Inside diameter of tube R mm (± 2 %)	Outside diameter of tubes L, N and P ²⁾ mm	Volume of bulb C ml (± 5 %)
M1	0,001	0,2 to 1	0,20	6 to 7	0,50
M2	0,005	1 to 5	0,30	6 to 7	0,50
M3	0,15	3 to 15	0,40	6 to 7	0,50
M4	0,04	8 to 40	0,50	6 to 7	0,50
M5	0,1	20 to 100	0,65	6 to 7	0,50

1) 200 s minimum flow time for all sizes.
2) Use 1 mm to 1,25 mm wall tubing for N, P and L.

Dimensions in millimetres
For tolerances on lengths, see 4.2

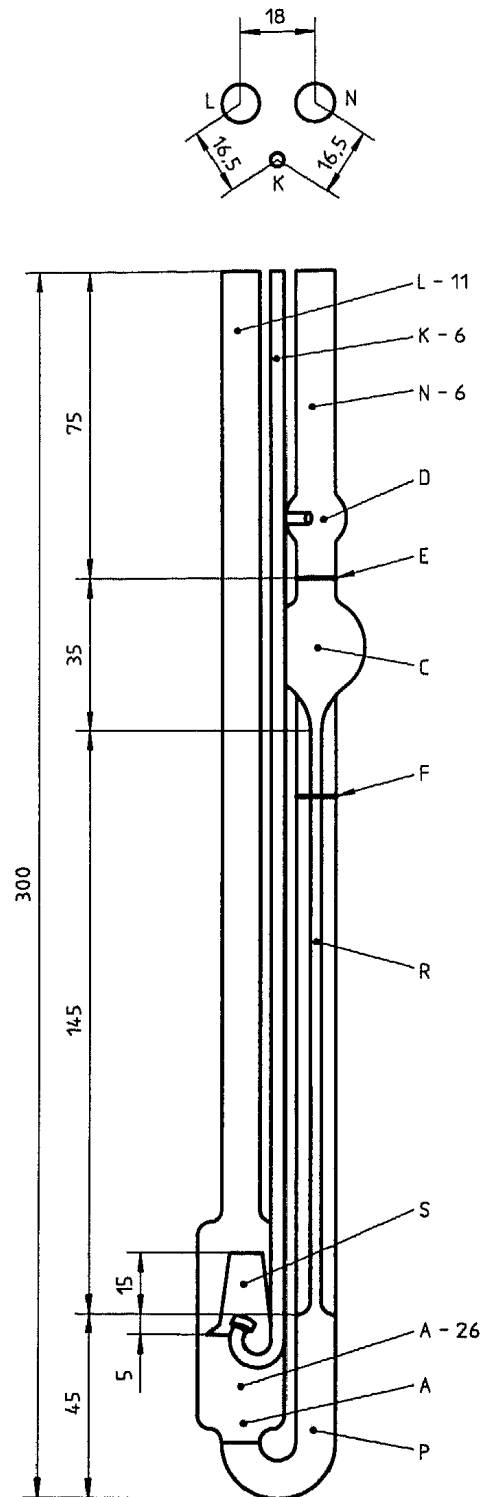

Figure A.5 — SIL viscometer

Table A.6 — SIL — Dimensions and kinematic viscosity ranges

Size No.	Nominal viscometer constant (mm ² /s)/s	Kinematic viscosity range ¹⁾ mm ² /s	Inside diameter of tube R mm (± 2 %)	Inside diameter of tubes E and P mm	Volume of bulb C ml (± 5 %)
0C	0,003	0,6 to 3	0,41	4,5 to 5,5	3,0
1	0,01	2,0 to 10	0,61	4,5 to 5,5	4,0
1C	0,03	6 to 30	0,79	4,5 to 5,5	4,0
2	0,1	20 to 100	1,14	4,5 to 5,5	5,0
2C	0,3	60 to 300	1,50	4,5 to 5,5	5,0
3	1,0	200 to 1 000	2,03	4,5 to 5,5	5,0
3C	3,0	600 to 3 000	2,68	4,5 to 5,5	5,0
4	10,0	2 000 to 10 000	3,61	4,5 to 5,5	5,0

1) 200 s minimum flow time for all sizes.

Dimensions in millimetres
For tolerances on lengths, see 4.2

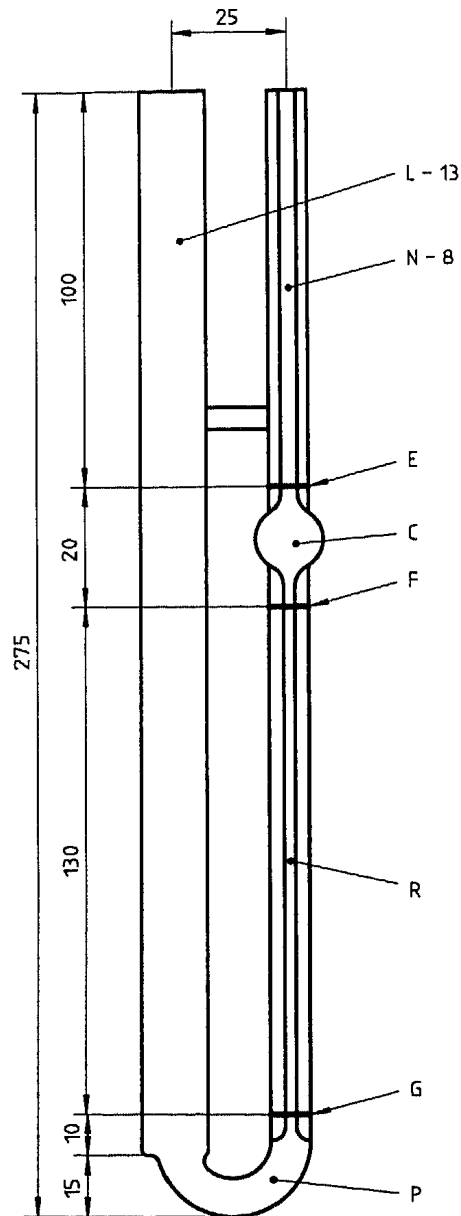

Figure A.6 — Cannon-Manning semimicro viscometer

Table A.7 — Cannon-Manning semimicro — Dimensions and kinematic viscosity ranges

Size No.	Nominal viscometer constant (mm ² /s)/s	Kinematic viscosity range ¹⁾ mm ² /s	Inside diameter of tube R mm (± 2 %)	Inside diameter of tubes mm		Volume of bulb C ml (± 5 %)
				N	P	
25	0,002	0,4 to 2,0	0,22 ± 0,01	1,0 to 1,2	0,4 to 0,7	0,31
50	0,004	0,8 to 4	0,26 ± 0,01	1,0 to 1,2	0,5 to 0,8	0,31
75	0,008	1,6 to 8	0,31 ± 0,01	1,1 to 1,3	0,6 to 0,8	0,31
100	0,015	3 to 15	0,36 ± 0,02	1,2 to 1,4	0,7 to 0,9	0,31
150	0,035	7 to 35	0,47 ± 0,02	1,2 to 1,4	0,8 to 1,0	0,31
200	0,1	20 to 100	0,61 ± 0,02	1,4 to 1,7	0,9 to 1,2	0,31
300	0,25	50 to 250	0,76 ± 0,02	1,5 to 1,8	1,2 to 1,6	0,31
350	0,5	100 to 500	0,90 ± 0,03	1,8 to 2,2	1,5 to 1,8	0,31
400	1,2	240 to 1 200	1,13 ± 0,03	2,0 to 2,4	1,6 to 2,0	0,31
450	2,5	500 to 2 500	1,40 ± 0,04	2,2 to 2,6	2,0 to 2,5	0,31
500	8	1 600 to 8 000	1,85 ± 0,05	2,4 to 2,8	2,5 to 2,8	0,31
600	20	4 000 to 20 000	2,35 ± 0,05	3,0 to 3,4	2,7 to 3,0	0,31

1) 200 s minimum flow time for all sizes.

Dimensions in millimetres
For tolerances on lengths, see 4.2

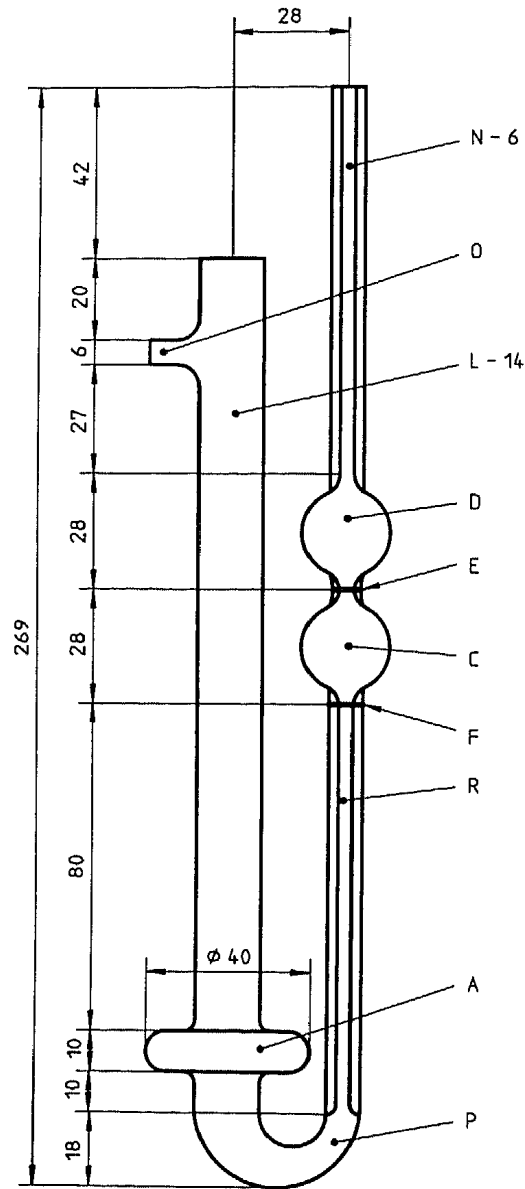

Figure A.7 — Pinkevitch viscometer

Table A.8 — Pinkevitch — Dimensions and kinematic viscosity ranges

Size No.	Nominal viscometer constant (mm ² /s)/s	Kinematic viscosity range mm ² /s	Inside diameter of tube R mm (± 2 %)	Inside diameter of tubes N, E and P mm (± 2 %)	Volume of bulb ml (± 5 %)	
					D	C
0	0,001 7	0,6 ¹⁾ to 1,7	0,40	0,40	3,7	3,7
1	0,008 5	1,7 to 8,5	0,60	0,60	3,7	3,7
2	0,027	5,4 to 27	0,80	0,80	3,7	3,7
3	0,065	13 to 65	1,00	1,00	3,7	3,7
4	0,14	28 to 140	1,20	1,20	3,7	3,7
5	0,35	70 to 350	1,50	1,50	3,7	3,7
6	1,0	200 to 1 000	2,00	2,00	3,7	3,7
7	2,6	520 to 2 600	2,50	2,50	3,7	3,7
8	5,3	1 060 to 5 300	3,00	3,00	3,7	3,7
9	9,9	1 980 to 9 900	3,50	3,50	3,7	3,7
10	17	3 400 to 17 000	4,00	4,00	3,7	3,7

1) 350 s minimum flow time; 200 s minimum flow time for all other sizes.

Annex B (normative)

Suspended-level viscometers

B.1 General

Suspended-level viscometers include the BS/IP/SL, BS/IP/SL(S), BS/IP/MSL, Ubbelohde, FitzSimons, Atlantic, Cannon-Ubbelohde, and Cannon-Ubbelohde semimicro designs. The distinctive feature of suspended-level viscometers is that the liquid is suspended in the capillary which it fills completely. This suspension ensures a uniform driving head of liquid, independent of the quantity of sample charged into the viscometer, making the viscometer constant independent of temperature. By making the diameter of the lower meniscus approximately equal to the average diameter of the upper meniscus, the surface tension correction is greatly reduced. Suspended-level viscometers are used for the measurement of kinematic viscosities of transparent, Newtonian liquids up to 100 000 mm²/s.

For the suspended-level viscometers, detailed drawings, size designations, nominal viscometer constants, kinematic viscosity ranges, capillary diameters and bulb volumes for each viscometer are shown in figures B.1 to B.9.

B.2 Operating instructions

A standard operating procedure, applicable to all glass capillary kinematic viscometers, is contained in ISO 3104. Operating instructions for the suspended-level types are outlined in B.2.1 to B.2.6 with emphasis on procedures that are specific to this group of viscometers.

B.2.1 Select a clean, dry calibrated viscometer which will give a flow time greater than 200 s or the minimum shown in the appropriate table of dimensions, whichever is greater.

B.2.2 Charge the viscometer in the manner dictated by the design of the instrument, this operation being in conformity with that employed when the instrument was calibrated. If the sample is thought to contain fibres or solid particles, filter through a 75 µm screen during charging.

B.2.2.1 Charge the Ubbelohde and Cannon-Ubbelohde viscometers by tilting the instrument about 30° from the vertical and pouring sufficient sample through tube L into bulb A so that when the viscometer is returned to the vertical the meniscus is between fill marks G and H, and tube P completely fills without entrapping air. Mount the viscometer in the constant-temperature bath, keeping tube L vertical. To facilitate charging very viscous liquids, the viscometer may be inverted with tube L placed in the sample. Apply vacuum to tube N, closing tube M by a finger or rubber stopper; draw sufficient sample into tube L such that after wiping L clean and placing the viscometer in the constant-temperature bath, bulb A will fill as described above. The Cannon-Ubbelohde semimicro design omits marks G and H, since this viscometer is designed both for semimicro and dilution use; pour sufficient sample through L into bulb A to ensure that capillary R and bulb C can be filled as described in B.2.4.

B.2.2.2 Charge the BS/IP/SL, BS/IP/SL(S), BS/IP/MSL and FitzSimons viscometers through tube L with sufficient sample to fill bulb A, but not bulb B. The viscometer may be mounted vertically in the constant-temperature bath either prior to or following charging of the sample into the viscometer.

B.2.2.3 Permanently mount the Atlantic viscometer in the constant-temperature bath with the enlargement S resting on the top-split collar, and the lower end of capillary tube R 25 mm from the bottom of the bath. Pour the sample into a clean 50-ml beaker. Charge the viscometer by positioning the beaker and sample under tube L so that it will be immersed in the sample. Slowly apply vacuum to tube N by turning the three-way stopcock O to vacuum. Draw the sample into the viscometer filling capillary R, timing bulb C, and partially filling upper bulb D. Close stopcock O, holding the sample in the viscometer. If only a small sample is available, a short length of rubber-tipped glass tubing can be placed in the beaker with the rubber against the bottom of capillary tube R, and the sample drawn up as above.

B.2.3 Allow the charged viscometer to remain in the bath long enough to reach the test temperature. Because this time will vary for different instruments, for different temperatures and for different kinematic viscosities, establish a safe equilibrium time by trial (30 min should be sufficient except for the highest kinematic viscosities). One bath is often used to accommodate several viscometers. Never add or withdraw a viscometer while any other viscometer is in use for measuring a flow time.

B.2.4 Except for the Atlantic viscometer which already has the sample in position, close tube M with the finger and use vacuum (or pressure, if the sample contains volatile constituents) to draw the sample slowly through bulb C to about 8 mm above upper timing mark E. Release vacuum from tube N and immediately place a finger from tube M to tube N, holding the meniscus above timing mark E until the lower meniscus has dropped below the end of capillary R in bulb B. Release finger and allow the sample to flow by gravity.

B.2.5 Measure, to the nearest 0,1 s, the time required for the leading edge of the meniscus to pass from timing mark E to timing mark F. If this flow time is less than 200 s, select a smaller capillary viscometer and repeat B.2.2 through B.2.5.

B.2.6 Repeat steps B.2.4 and B.2.5, making a duplicate measurement of flow time. If the two measurements agree within the determinability given in ISO 3104 for the petroleum product being measured, use the average for calculating the kinematic viscosity.

B.2.7 Clean the viscometer thoroughly by several rinsings with an appropriate solvent completely miscible with the sample, followed by rinsing with a completely volatile solvent. Dry the viscometer by passing a slow stream of filtered, dry air through the viscometer for 2 min, or until the last trace of solvent is removed. The use of alkaline cleaning solutions is not recommended, as changes in the viscometer calibration may occur.

Dimensions in millimetres
For tolerances on lengths, see 4.2

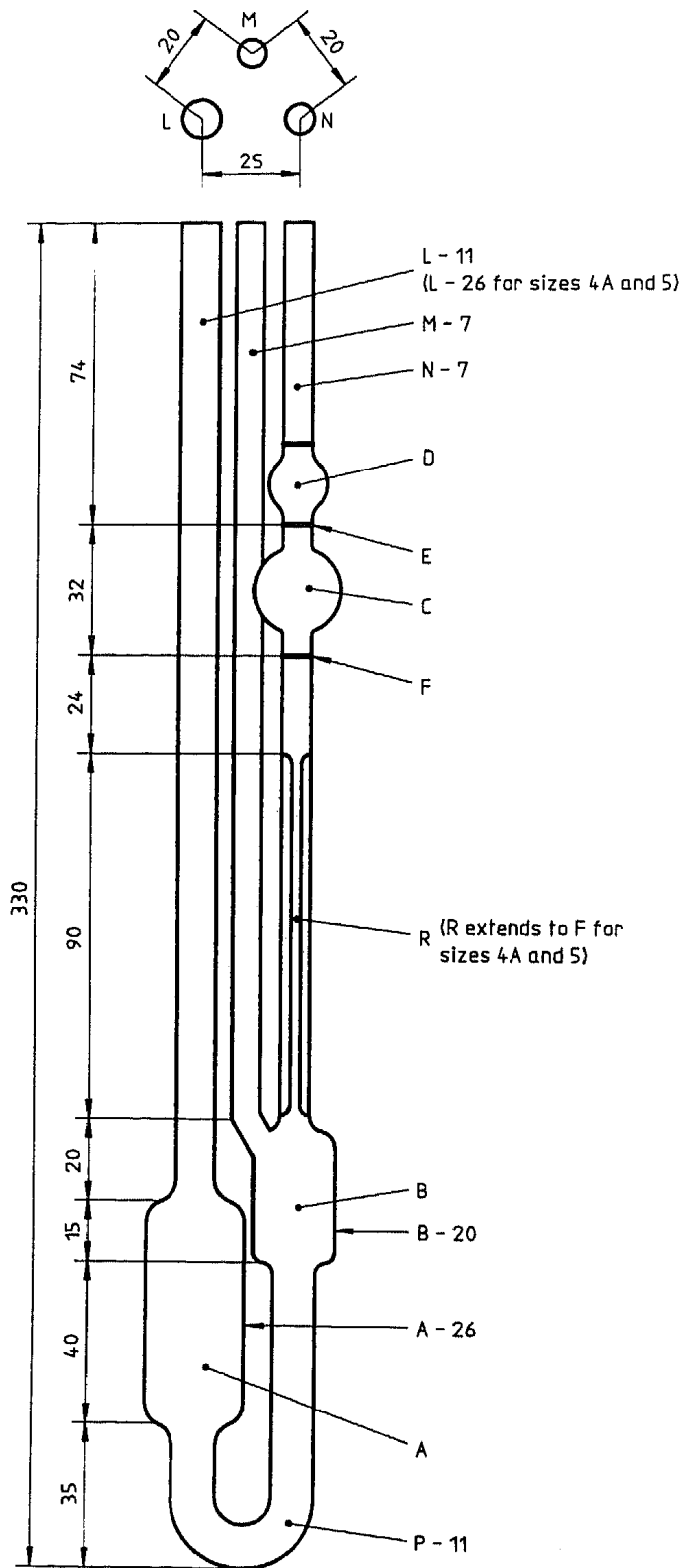

Figure B.1 — BS/IP/SL viscometer

Table B.1 — BS/IP/SL — Dimensions and kinematic viscosity ranges

Size No.	Nominal viscometer constant (mm ² /s)/s	Kinematic viscosity range mm ² /s	Inside diameter of tube R mm (± 2 %)	Inside diameter of tubes E and P ml (± 5 %)	Volume of bulb C (mm)
1	0,01	3,5 ¹⁾ to 10	0,64	5,6	2,8 to 3,2
1A	0,03	6 to 30	0,84	5,6	2,8 to 3,2
2	0,1	20 to 100	1,15	5,6	2,8 to 3,2
2A	0,3	60 to 300	1,51	5,6	2,8 to 3,2
3	1,0	200 to 1 000	2,06	5,6	3,7 to 4,3
3A	3,0	600 to 3 000	2,74	5,6	4,6 to 5,4
4	10	2 000 to 10 000	3,70	5,6	4,6 to 5,4
4A	30	6 000 to 30 000	4,97	5,6	5,6 to 6,4
5	100	20 000 to 100 000	6,76	5,6	6,8 to 7,5

1) 350 s minimum flow time; 200 s minimum flow time for all other sizes.

Dimensions in millimetres
For tolerances on lengths, see 4.2

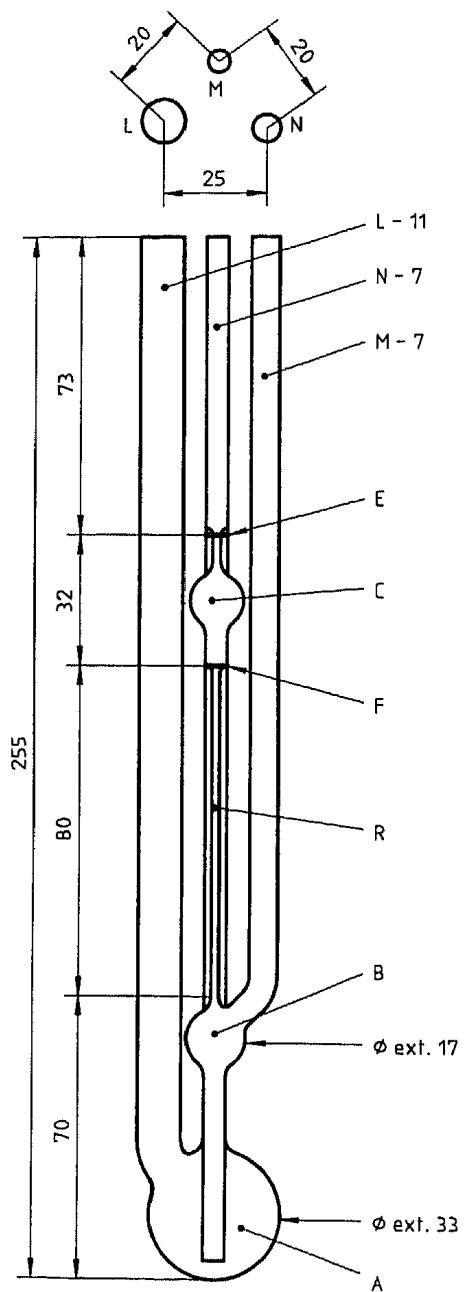

Figure B.2 — BS/IP/SL(S) viscometer

Table B.2 — BS/IP/SL(S) — Dimensions and kinematic viscosity ranges

Size No.	Nominal viscometer constant (mm ² /s)/s	Kinematic viscosity range mm ² /s	Inside diameter of tube R mm (± 2 %)	Volume of bulb C ml (± 5 %)	Inside diameter of tube N mm	Inside diameter of tube at E mm
1	0,000 8	1,05 ¹⁾ min	0,36	5,6	2,8 to 3,2	3
2	0,003	2,1 ²⁾ to 3	0,49	5,6	2,8 to 3,2	3
3	0,01	3,8 ³⁾ to 10	0,66	5,6	2,8 to 3,2	3
4	0,03	6 to 30	0,87	5,6	2,8 to 3,2	3
5	0,1	20 to 100	1,18	5,6	2,8 to 3,2	3
6	0,3	60 to 300	1,55	5,6	2,8 to 3,2	3
7	1,0	200 to 1 000	2,10	5,6	2,8 to 3,2	4
8	3,0	600 to 3 000	2,76	5,6	2,8 to 3,2	5
9	10,0	2 000 to 10 000	3,80	5,6	2,8 to 3,2	5

1) 1 320 s minimum flow time.

2) 600 s minimum flow time.

3) 380 s minimum flow time; 200 s minimum flow time for all other sizes.

Dimensions in millimetres
For tolerances on lengths, see 4.2

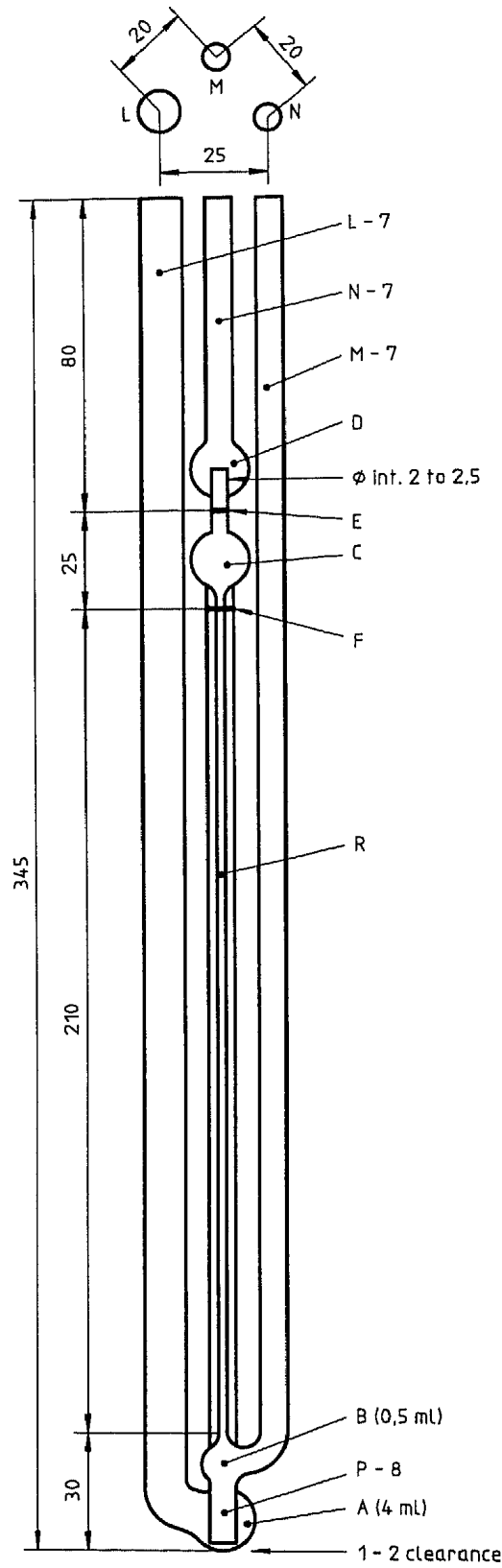

Figure B.3 — BS/IP/MSL viscometer

Table B.3 — BS/IP/MSL — Dimensions and kinematic viscosity ranges

Size No.	Nominal viscometer constant (mm ² /s)/s	Kinematic viscosity range ¹⁾ mm ² /s	Inside diameter of tube R mm (± 2 %)	Volume of bulb C ml (± 5 %)	Inside diameter of tubes N and P mm
1	0,003	0,6 to 3	0,35	1,2	4 to 6
2	0,01	2 to 10	0,45	1,2	4 to 6
3	0,03	6 to 30	0,62	1,2	4 to 6
4	0,1	20 to 100	0,81	1,2	4 to 6
5	0,3	60 to 300	1,10	1,2	4 to 6
6	1,0	200 to 1 000	1,45	1,2	4 to 6
7	3,0	600 to 3 000	1,98	1,2	4 to 6

1) 200 s minimum flow time for all sizes.

Dimensions in millimetres
For tolerances on lengths, see 4.2

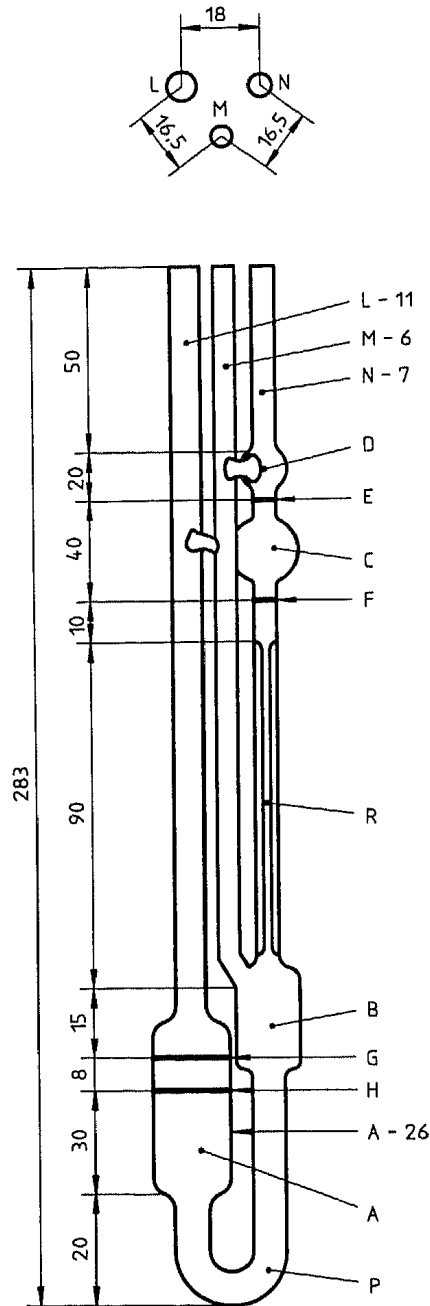

Figure B.4 — Ubbelohde viscometer

Table B.4 — Ubbelohde — Dimensions and kinematic viscosity ranges

Size No.	Nominal viscometer constant (mm ² /s)/s	Kinematic viscosity range mm ² /s	Inside diameter of tube R mm (± 2 %)	Volume of bulb C ml (± 5 %)	Inside diameter of tube P mm (± 5 %)
0	0,001	0,3 ¹⁾ to 1	0,24	1,0	6,0
0C	0,003	0,6 to 3	0,36	2,0	6,0
0B	0,005	1 to 5	0,46	3,0	6,0
1	0,01	2 to 10	0,58	4,0	6,0
1C	0,03	6 to 30	0,77	4,0	6,0
1B	0,05	10 to 50	0,88	4,0	6,0
2	0,1	20 to 100	1,03	4,0	6,0
2C	0,3	60 to 300	1,36	4,0	6,0
2B	0,5	100 to 500	1,55	4,0	6,0
3	1,0	200 to 1 000	1,83	4,0	6,0
3C	3,0	600 to 3 000	2,43	4,0	6,0
3B	5,0	1 000 to 5 000	2,75	4,0	6,5
4	10	2 000 to 10 000	3,27	4,0	7,0
4C	30	6 000 to 30 000	4,32	4,0	8,0
4B	50	10 000 to 50 000	5,20	5,0	8,5
5	100	20 000 to 100 000	6,25	5,0	10,0

1) 300 s minimum flow time; 200 s minimum flow time for all other sizes.

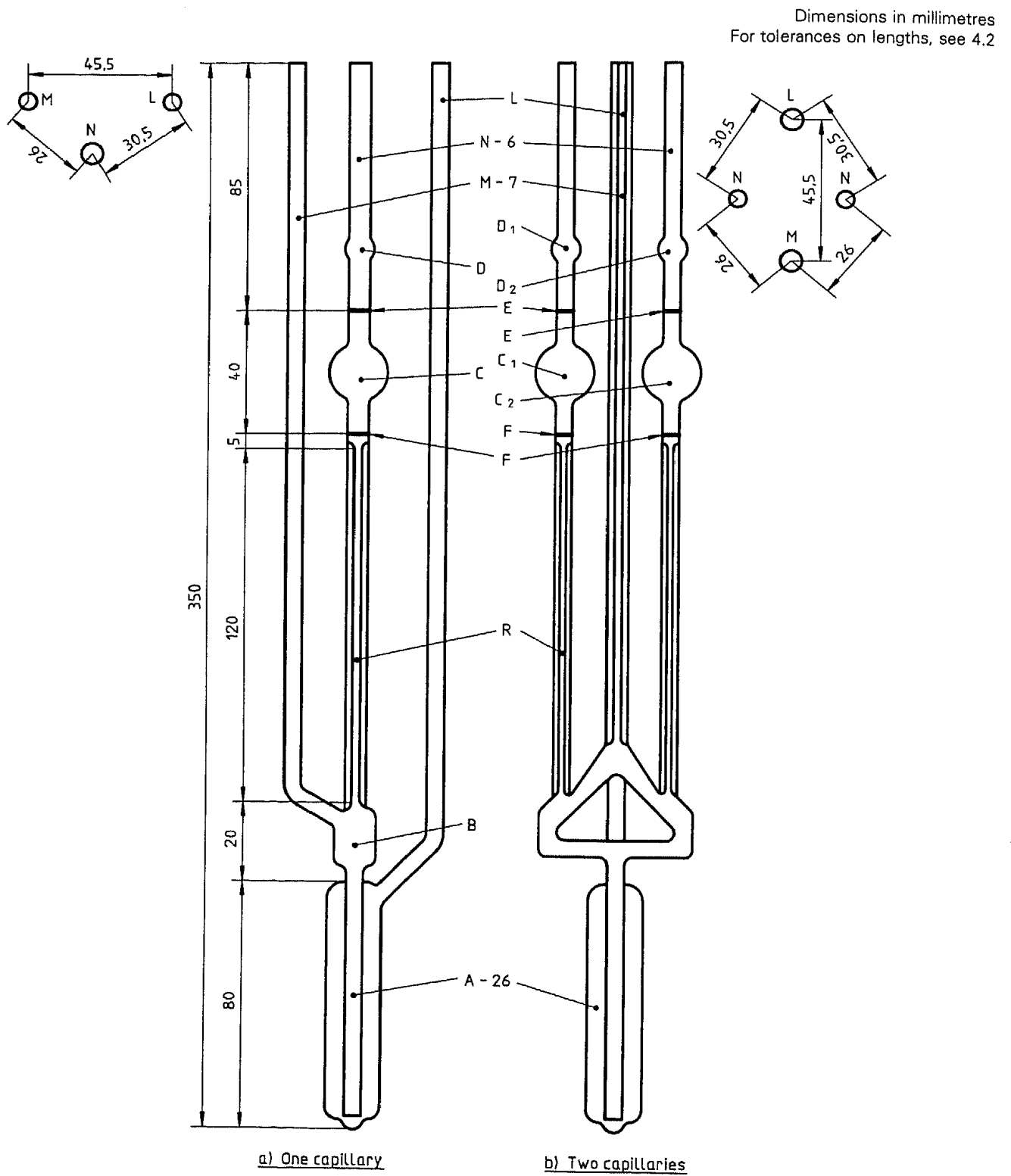

Figure B.5 — FitzSimons viscometer

Table B.5 — FitzSimons — Dimensions and kinematic viscosity ranges

Size No.	Nominal viscometer constant (mm ² /s)/s	Kinematic viscosity range ¹⁾ mm ² /s	Inside diameter of tube R mm (± 2 %)	Volume of bulb C ml (± 5 %)
1	0,003	0,6 to 3,0	0,43	3,0
2	0,01	2 to 10	0,60	3,7
3	0,035	7 to 35	0,81	3,7
4	0,10	20 to 100	1,05	3,7
5	0,25	50 to 150	1,32	3,7
6	1,20	240 to 1 200	1,96	3,7

1) 200 s minimum flow time for all sizes.

Dimensions in millimetres
For tolerances on lengths, see 4.2

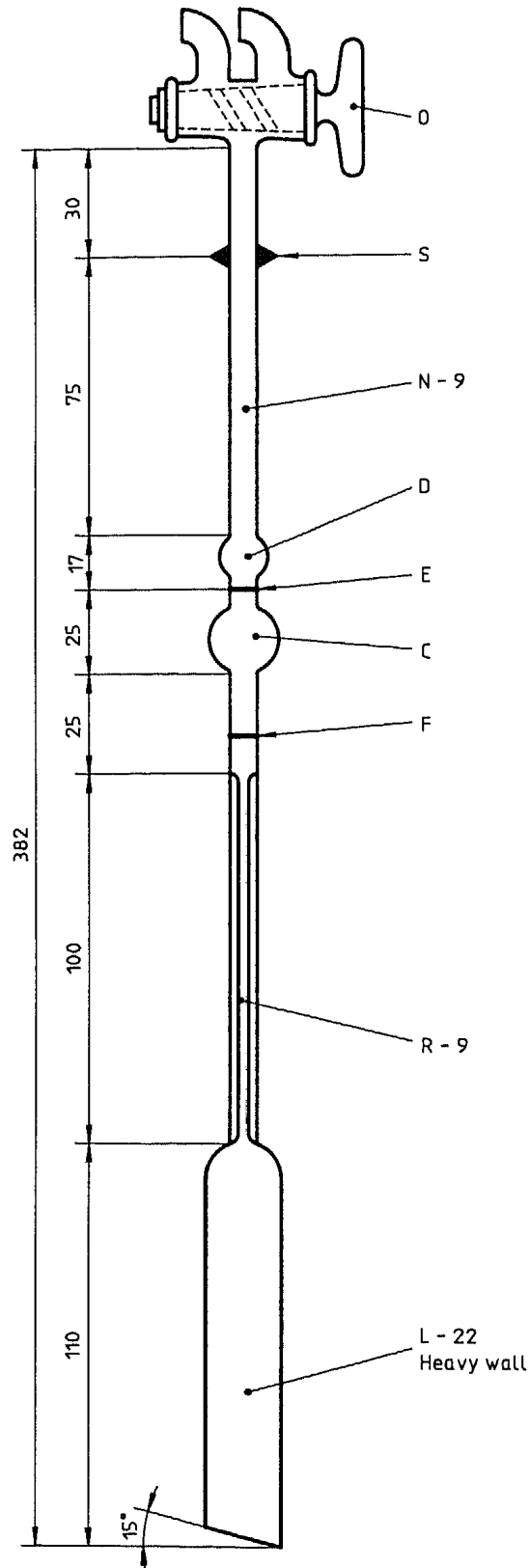

Figure B.6 — Atlantic viscometer

Table B.6 — Atlantic — Dimensions and kinematic viscosity ranges

Size No.	Nominal viscometer constant (mm ² /s)/s	Kinematic viscosity range mm ² /s	Inside diameter of tube R mm (± 2 %)	Volume of bulb C ml (± 5 %)
0C	0,003	0,75 ¹⁾ to 3	0,42	3,2
0B	0,005	1 to 5	0,46	3,2
1	0,01	2 to 10	0,56	3,2
1C	0,03	6 to 30	0,74	3,2
1B	0,05	10 to 50	0,83	3,2
2	0,1	20 to 100	1,00	3,2
2C	0,3	60 to 300	1,31	3,2
2B	0,5	100 to 500	1,48	3,2
3	1,0	200 to 1 000	1,77	3,2
3C	3,0	600 to 3 000	2,33	3,2
3B	5,0	1 000 to 5 000	2,64	3,2

1) 250 s minimum flow time; 200 s minimum flow time for all other sizes.

Dimensions in millimetres
For tolerances on lengths, see 4.2

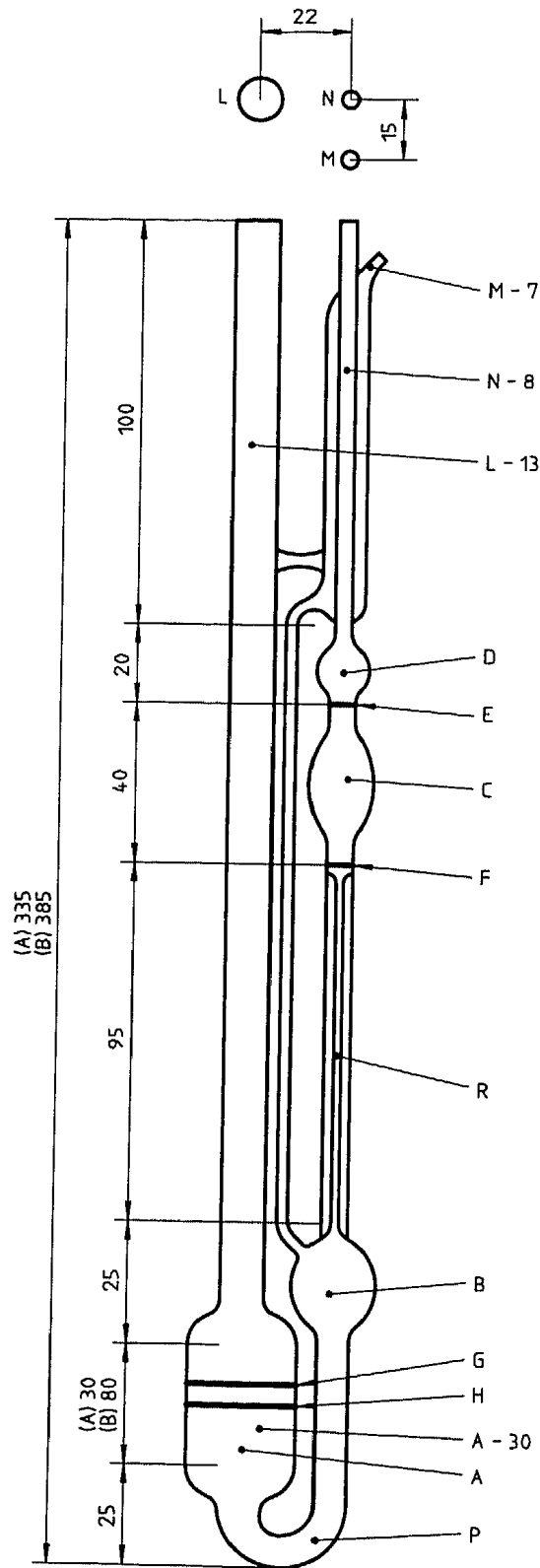

Figure B.7 — Cannon-Ubbelohde (A) and Cannon-Ubbelohde dilution (B) viscometer

Table B.7 — Cannon-Ubbelohde and Cannon-Ubbelohde dilution — Dimensions and kinematic viscosity ranges

Size No.	Nominal viscometer constant (mm ² /s)/s	Kinematic viscosity range mm ² /s	Inside diameter of tube R mm (± 2 %)	Volume of bulb C ml (± 5 %)
25	0,002	0,5 ¹⁾ to 2	0,31	1,5
50	0,004	0,8 to 4,0	0,44	3,0
75	0,008	1,6 to 8,0	0,54	3,0
100	0,015	3 to 15	0,63	3,0
150	0,035	7 to 35	0,78	3,0
200	0,1	20 to 100	1,01	3,0
300	0,25	50 to 250	1,26	3,0
350	0,5	100 to 500	1,48	3,0
400	1,2	240 to 1 200	1,88	3,0
450	2,5	500 to 2 500	2,25	3,0
500	8	1 600 to 8 000	3,00	3,0
600	20	4 000 to 20 000	3,75	3,0
650	45	9 000 to 45 000	4,60	3,0
700	100	20 000 to 100 000	5,60	3,0

1) 250 s minimum flow time; 200 s minimum flow time for all other sizes.

Dimensions in millimetres
For tolerances on lengths, see 4.2

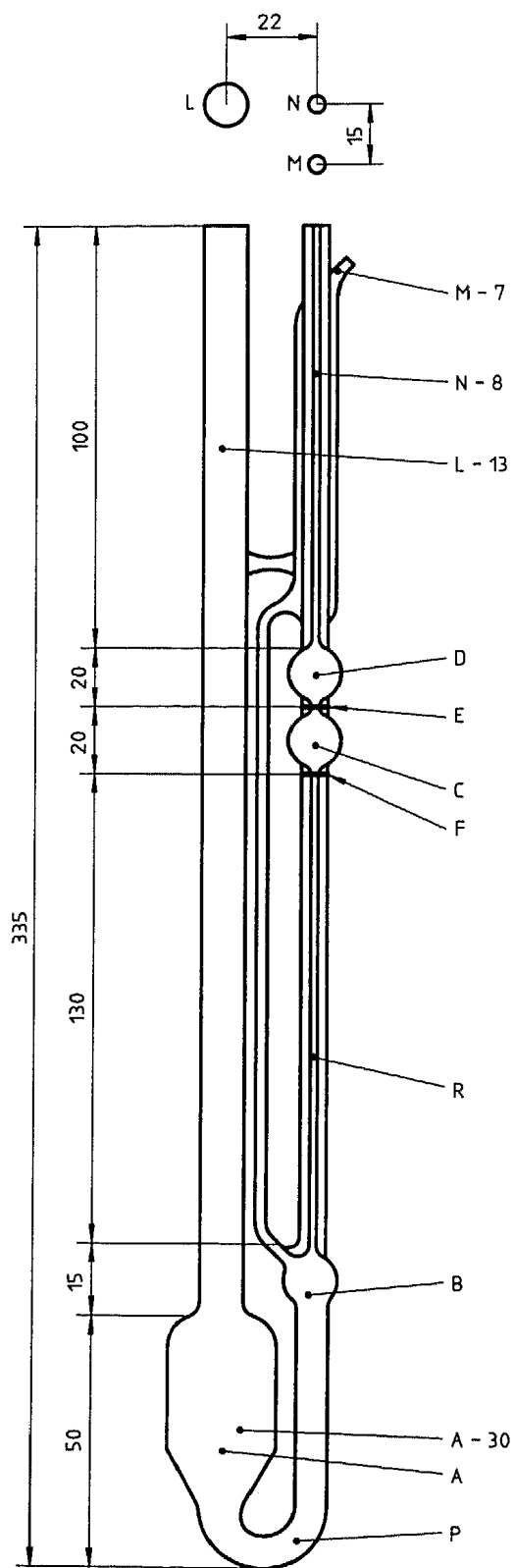

Figure B.8 — Cannon-Ubbelohde semimicro viscometer

Table B.8 — Cannon-Ubbelohde semimicro — Dimensions and kinematic viscosity ranges

Size No.	Nominal viscometer constant (mm ² /s)/s	Kinematic viscosity range ¹⁾ mm ² /s	Inside diameter of tube R mm (± 2 %)	Volume of bulb C ml (± 5 %)	Inside diameter of tubes N, E, F and P mm
25	0,002	0,4 to 2,0	0,22	0,30	1,2 to 1,4
50	0,004	0,8 to 4	0,25	0,30	1,2 to 1,4
75	0,008	1,6 to 8	0,30	0,30	1,2 to 1,4
100	0,015	3 to 15	0,36	0,30	1,2 to 1,4
150	0,035	7 to 35	0,47	0,30	1,2 to 1,4
200	0,1	20 to 100	0,61	0,30	1,4 to 1,7
300	0,25	50 to 250	0,76	0,30	1,5 to 1,8
350	0,5	100 to 500	0,90	0,30	1,8 to 2,2
400	1,2	240 to 1 200	1,13	0,30	2,1 to 2,5
450	2,5	500 to 2 500	1,40	0,30	2,4 to 2,8
500	8	1 600 to 8 000	1,85	0,30	2,7 to 3,1
600	20	4 000 to 20 000	2,35	0,30	3,7 to 4,0

1) 200 s minimum flow time for all sizes.

Dimensions in millimetres
For tolerances on lengths, see 4.2

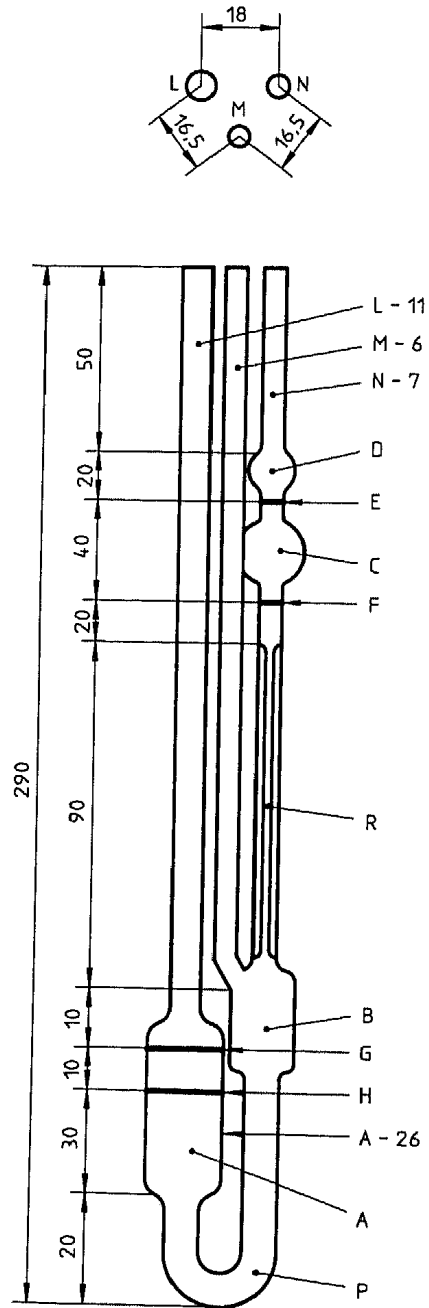

Figure B.9 — DIN Ubbelohde viscometer

Table B.9 — DIN Ubbelohde — Dimensions and kinematic viscosity ranges

Size No.	Nominal viscometer constant (mm ² /s)/s	Kinematic viscosity range mm ² /s	Inside diameter of tube R mm (± 2 %)	Volume of bulb C ml (± 5 %)
0	0,001	0,35 ¹⁾ to 1	0,36	5,7
0c	0,003	0,7 to 3	0,47	5,7
0a	0,005	1 to 5	0,53	5,7
I	0,01	2 to 10	0,63	5,7
Ic	0,03	6 to 30	0,84	5,7
Ia	0,05	10 to 50	0,95	5,7
II	0,1	20 to 100	1,13	5,7
IIc	0,3	60 to 300	1,50	5,7
Ila	0,5	100 to 500	1,69	5,7
III	1	200 to 1 000	2,01	5,7
IIIc	3	600 to 3 000	2,65	5,7
IIIa	5	1 000 to 5 000	3,00	5,7
IV	10	2 000 to 10 000	3,60	5,7
IVc	30	6 000 to 30 000	4,70	5,7
IVa	50	10 000 to 50 000	5,34	5,7

1) 350 s minimum flow time: 200 s minimum flow time for all other sizes.

Annex C (normative)

Reverse-flow viscometers

C.1 General

The reverse-flow viscometers for transparent and opaque liquids include the Zeitfuchs cross-arm, Cannon-Fenske opaque, BS/IP/RF and Lantz-Zeitfuchs viscometers. Unlike the modified Ostwald and suspended-level viscometers, the sample of liquid flows into a timing bulb not previously wetted by the sample, thus allowing the timing of liquids whose thin films are opaque. Reverse-flow viscometers are used for the measurement of kinematic viscosities of opaque and transparent liquids of up to 300 000 mm²/s.

For the reverse-flow viscometers, detailed drawings, size designations, nominal viscometer constants, kinematic viscosity ranges, capillary diameters and bulb volumes for each viscometer are shown in figures C.1 to C.4.

C.2 Operating instructions

A standard operating procedure applicable to all glass capillary kinematic viscometers is contained in ISO 3104. Operating instructions for the reverse-flow viscometers are outlined in C.2.1 to C.2.6 with emphasis on procedures that are specific to a particular instrument or this group of instruments.

C.2.1 Select a clean, dry calibrated viscometer which will give a flow time greater than 200 s and a kinetic energy correction of less than 0,2 %.

C.2.2 Charge the viscometer in the manner dictated by the design of the instrument, this operation being in conformity with that employed when the instrument was calibrated. If the sample is thought to contain fibres or solid particles, filter through a 75 µm screen during charging.

C.2.2.1 To charge the Cannon-Fenske opaque viscometer, invert the viscometer and apply suction to the tube L, immersing tube N in the liquid sample. Draw liquid through tube N, filling bulb D to filling mark G. Wipe any excess sample off tube N and invert the viscometer to its normal position. Mount the viscometer in the constant-temperature bath, keeping

tube L vertical. Close tube N with a rubber stopper or a short length of rubber tube with a screw clamp.

C.2.2.2 Mount the Zeitfuchs cross-arm viscometer in the constant-temperature bath, keeping tube N vertical. Introduce the sample through tube N, taking care not to wet the sides of tube N, into the cross-arm D until the leading edge stands within 0,5 mm of fill mark G on the siphon tube.

C.2.2.3 Mount the Lantz-Zeitfuchs viscometer in the constant-temperature bath, keeping tube N vertical. Introduce sufficient sample through tube N to completely fill bulb D, overflowing slightly into overflow tube K. If the sample is poured at a temperature above the test temperature, wait 15 min for the sample in the viscometer to attain bath temperature and add more sample to overflow slightly into tube K.

C.2.2.4 Mount the BS/IP/RF viscometer in the constant-temperature bath, keeping the straight portion of the capillary tube R vertical, by using a plumb-line observed in two directions at right angles, or as stated in the certificate of calibration.

Allow the viscometer to reach the bath temperature and then pour sufficient of the filtered test sample into the filling tube N to a point just below the filling mark G, avoiding wetting the glass above G.

Allow the liquid to flow through the capillary tube R, taking care that the liquid column remains unbroken, until it reaches a position about 5 mm below the filling mark H and arrest its flow at this point by closing the timing tube L with a rubber stopper. It is desirable that the rubber stopper is fitted with a glass tube and stopcock so that one can apply a controllable, very slight excess pressure to tube L.

Add more liquid to the filling tube N to bring the oil surface to just below mark G. Allow the sample to reach the bath temperature and air bubbles to rise to the surface (at least 30 min is required).

Gently manipulate the stopcock or stopper closing tube L until the level of the liquid is arrested at mark H. The uppermost ring of contact of the sample with

the glass should coincide with the bottom of mark H. Add sample to tube N until the uppermost ring of its contact with tube N coincides with the bottom of mark G.

C.2.3 Allow the charged viscometer to remain in the bath long enough to reach the test temperature. Because this time will vary for different instruments, for different temperatures and for different kinematic viscosities, establish a safe equilibrium time by trial (30 min should be sufficient except for the highest kinematic viscosities). One bath is often used to accommodate several viscometers. Never add or withdraw a viscometer while any other viscometer is in use for measuring a flow time.

C.2.4 For the Cannon-Fenske opaque and BS/IP/RF viscometers, remove the stopper in tubes N and L, respectively, and allow the sample to flow by gravity. For the Zeitfuchs cross-arm viscometer, apply slight vacuum to tube M (or pressure to tube N) to cause the meniscus to move over the siphon tube, and about 30 mm below the level of tube D in capillary R; gravity flow is thus initiated. For the Lantz-Zeitfuchs viscometer, apply slight vacuum to tube M (or pressure tube N with tube K closed) until the lower meniscus is opposite the lower timing mark E; allow the sample to flow by gravity.

C.2.5 Measure to the nearest 0,1 s the time required for the uppermost ring of sample contact with the glass to rise from the bottom of timing mark E to the bottom of timing mark F. The lower filling mark H, if applicable, must not be confused with the lower timing mark E. If the flow time is less than the minimum specified for the viscometer, select a clean, dry viscometer with a smaller diameter capillary and repeat steps C.2.1 to C.2.5.

C.2.6 Using this viscometer after a thorough cleaning and drying, or a second clean and dry viscometer, repeat steps C.2.2 to C.2.5, making a duplicate determination of the kinematic viscosity. If the two determinations agree within the determinability given in ISO 3104 for the petroleum product being measured, report the average of the calculated kinematic viscosities. Note that the precision of the viscometers in annex C is slightly poorer than those in annexes A and B. See 6.3.2.

C.2.7 Clean the viscometer thoroughly by several rinsings with an appropriate solvent completely miscible with the sample, followed by a completely volatile solvent. Dry the viscometer by passing a slow stream of filtered, dry air through the viscometer for 2 min, or until the last trace of solvent is removed. The use of alkaline cleaning solutions is not recommended, as changes in viscometer calibration may occur.

Dimensions in millimetres
For tolerances on lengths, see 4.2

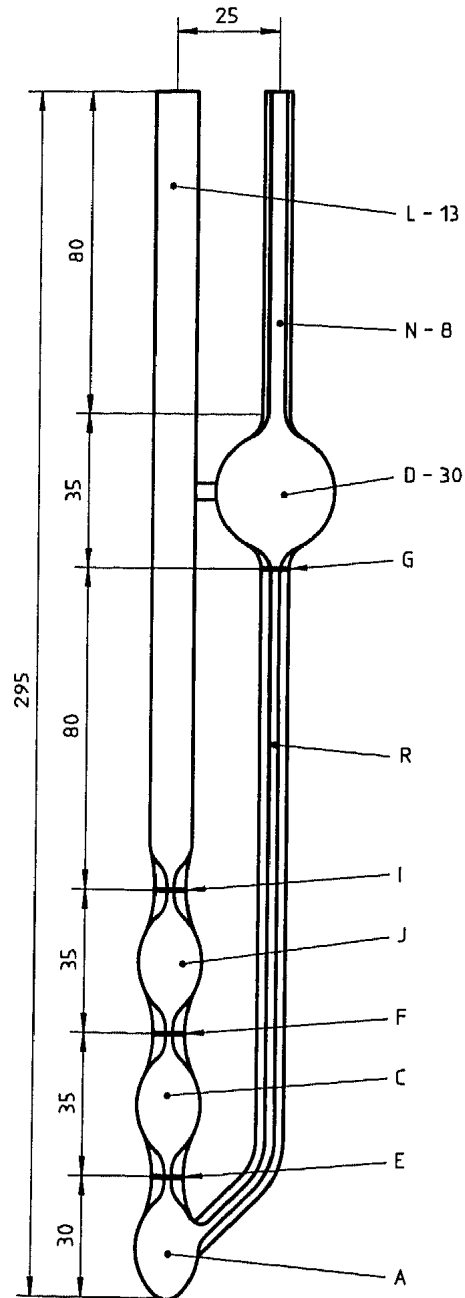

Figure C.1 — Cannon-Fenske opaque viscometer

Table C.1 — Cannon-Fenske opaque — Dimensions and kinematic viscosity ranges

Size No.	Nominal viscometer constant (mm ² /s)/s	Kinematic viscosity range ¹⁾ mm ² /s	Inside diameter of tube R mm (± 2 %)	Inside diameter of tube N and tubes E, F and I mm (± 5 %)	Volume of bulbs A, C and J ml (± 5 %)	Volume of bulb D ml (± 5 %)
25	0,002	0,4 to 2	0,31	3,0	1,6	1,1
50	0,004	0,8 to 4	0,42	3,0	2,1	11
75	0,008	1,6 to 8	0,54	3,0	2,1	11
100	0,015	3 to 15	0,63	3,2	2,1	11
150	0,035	7 to 35	0,78	3,2	2,1	11
200	0,1	20 to 100	1,02	3,2	2,1	11
300	0,25	50 to 200	1,26	3,4	2,1	11
350	0,5	100 to 500	1,48	3,4	2,1	11
400	1,2	240 to 1 200	1,88	3,4	2,1	11
450	2,5	500 to 2 500	2,20	3,7	2,1	11
500	8	1 600 to 8 000	3,10	4,0	2,1	11
600	20	4 000 to 20 000	4,00	4,7	2,1	13

1) 200 s minimum flow time for all sizes.

Dimensions in millimetres
For tolerances on lengths, see 4.2

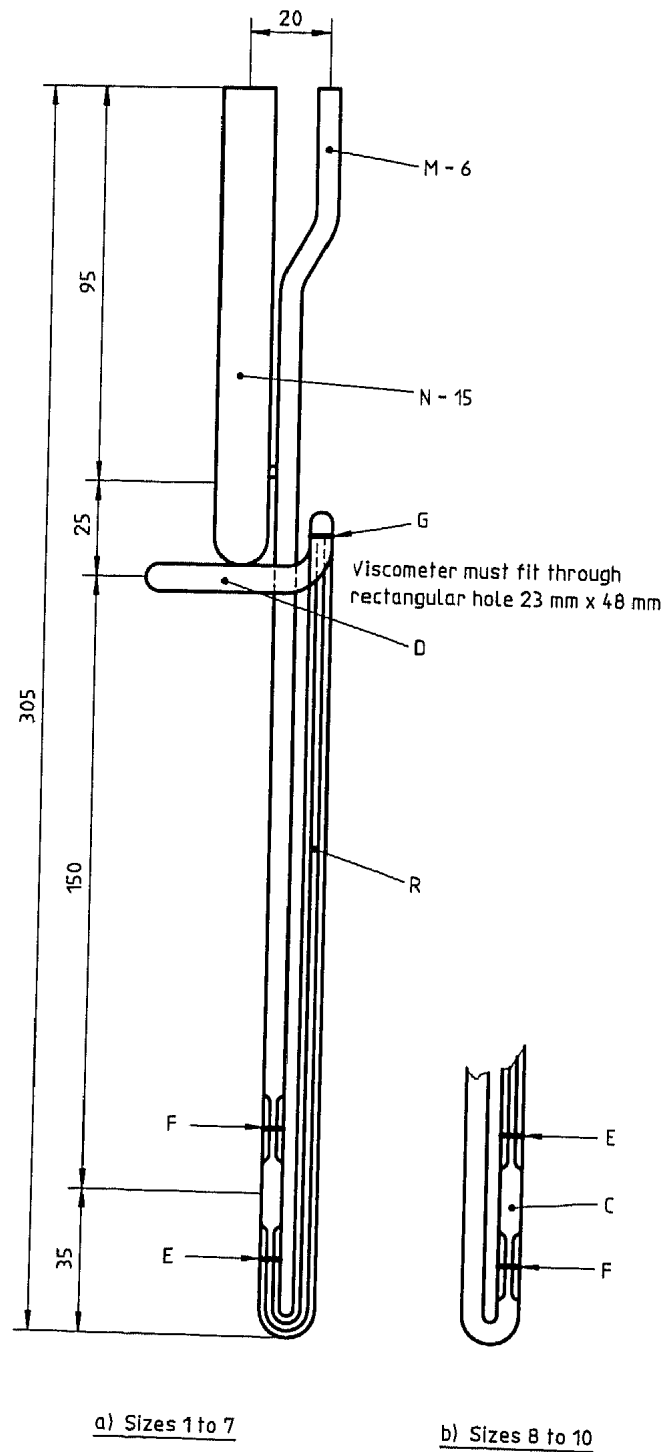

Figure C.2 — Zeitfuchs cross-arm viscometer

Table C.2 — Zeitfuchs cross-arm — Dimensions and kinematic viscosity ranges

Size No.	Nominal viscometer constant (mm ² /s)/s	Kinematic viscosity range ¹⁾ mm ² /s	Inside diameter of tube R mm (± 2 %)	Length of tube R mm	Lower bulb volume ml (± 5 %)	Horizontal tube diameter mm (± 5 %)
1	0,003	0,6 to 3	0,26	210	0,25	3,9
2	0,01	2 to 10	0,35	210	0,25	3,9
3	0,03	6 to 30	0,47	210	0,25	3,9
4	0,10	20 to 100	0,63	210	0,25	3,9
5	0,3	60 to 300	0,84	210	0,25	3,9
6	1,0	200 to 1 000	1,12	210	0,25	4,3
7	3,0	600 to 3 000	1,48	210	0,25	4,3
8	10,0	2 000 to 10 000	1,83	165	0,25	4,3
9	30,0	6 000 to 30 000	2,40	165	0,25	4,3
10	100,0	20 000 to 100 000	2,95	165	0,25	4,3

1) 200 s minimum flow time for all sizes.

Dimensions in millimetres
For tolerances on lengths, see 4.2

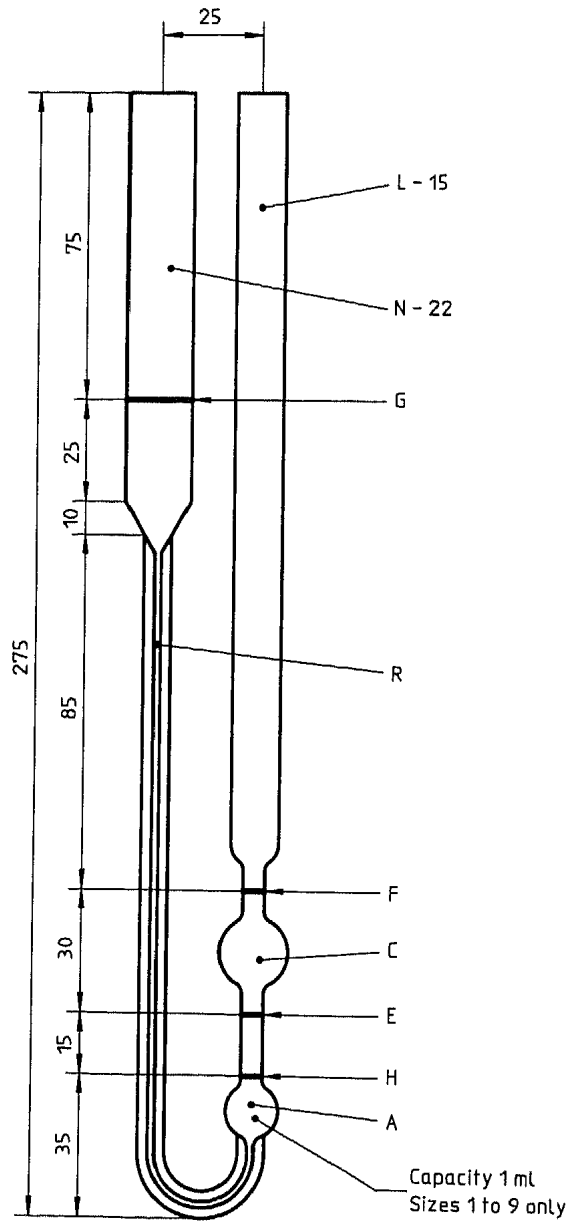

Figure C.3 — BS/IP/RF U-tube reverse-flow viscometer

Table C.3 — BS/IP/RF U-tube reverse-flow — Dimensions and kinematic viscosity ranges

Size No.	Nominal viscometer constant (mm ² /s)/s	Kinematic viscosity range ¹⁾ mm ² /s	Inside diameter of tube R mm (± 2 %)	Length of tube R mm	Inside diameter at E, F and H mm	Volume of bulb C ml (± 5 %)
1	0,003	0,6 to 3	0,51	185	3,0 to 3,3	4,0
2	0,01	2 to 10	0,71	185	3,0 to 3,3	4,0
3	0,03	6 to 30	0,93	185	3,0 to 3,3	4,0
4	0,1	20 to 100	1,26	185	3,0 to 3,3	4,0
5	0,3	60 to 300	1,64	135	3,0 to 3,3	4,0
6	1,0	200 to 1 000	2,24	185	3,0 to 3,3	4,0
7	3,0	600 to 3 000	2,93	185	3,3 to 3,6	4,0
8	10	2 000 to 10 000	4,00	185	4,4 to 4,8	4,0
9	30	6 000 to 30 000	5,5	185	6,0 to 6,7	4,0
10	100	20 000 to 100 000	7,70	210	7,70	4,0
11	300	60 000 to 300 000	10,00	210	10,00	4,0

1) 200 s minimum flow time for all sizes.

Dimensions in millimetres
For tolerances on lengths, see 4.2

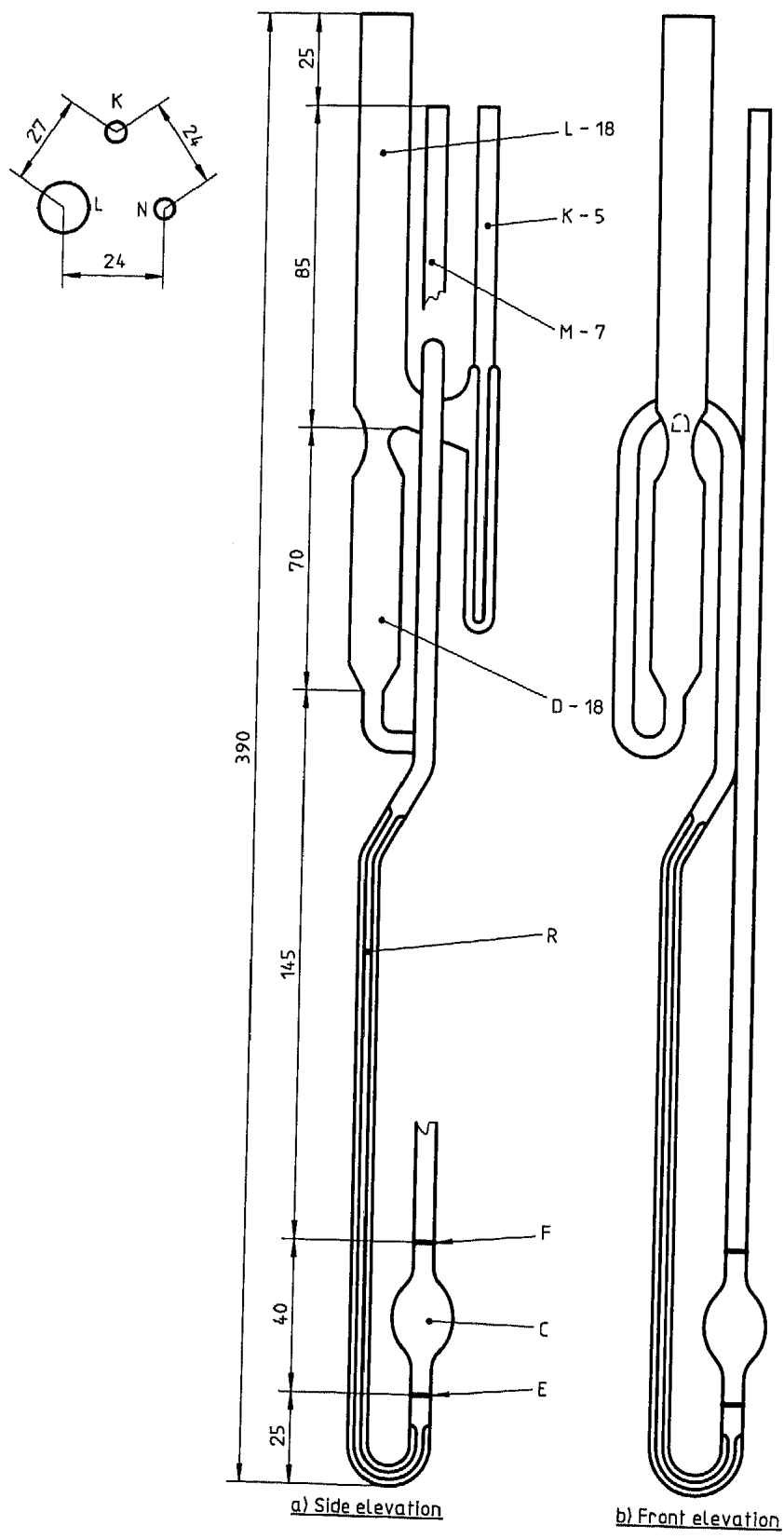

Figure C.4 — Lantz-Zeitfuchs type reverse-flow viscometer

Table C.4 — Lantz-Zeitfuchs reverse-flow — Dimensions and kinematic viscosity ranges

Size No.	Nominal viscometer constant (mm ² /s)/s	Kinematic viscosity range ¹⁾ mm ² /s	Inside diameter of tube R mm (± 2 %)	Length of tube R mm	Volume of bulb C ml (± 5 %)
5	0,3	60 to 300	1,65	490	2,7
6	1,0	200 to 1 000	2,25	490	2,7
7	3,0	600 to 3 000	3,00	490	2,7
8	10,0	2 000 to 10 000	4,10	490	2,7
9	30,0	6 000 to 30 000	5,20	490	2,7
10	100,0	20 000 to 100 000	5,20	490	0,85

1) 200 s minimum flow time for all sizes.

ICS 17.060.00

Descriptors: laboratory equipment, laboratory glassware, viscometers, capillary viscometers, specifications, dimensions, calibration, instructions.

Price based on 51 pages
