

INTERNATIONAL
STANDARD

ISO
3016

Second edition
1994-08-01

Corrected and reprinted
1995-03-15

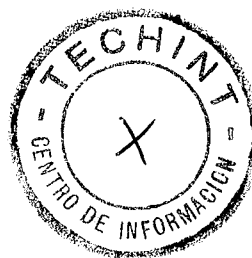

**Petroleum products — Determination of
pour point**

Produits pétroliers — Détermination du point d'écoulement

COPIA LEGAL AUTORIZADA
por convenio con IRAM
Instituto Argentino de Normalización
CENTRO DE DOCUMENTACIÓN



Reference number
ISO 3016:1994(E)

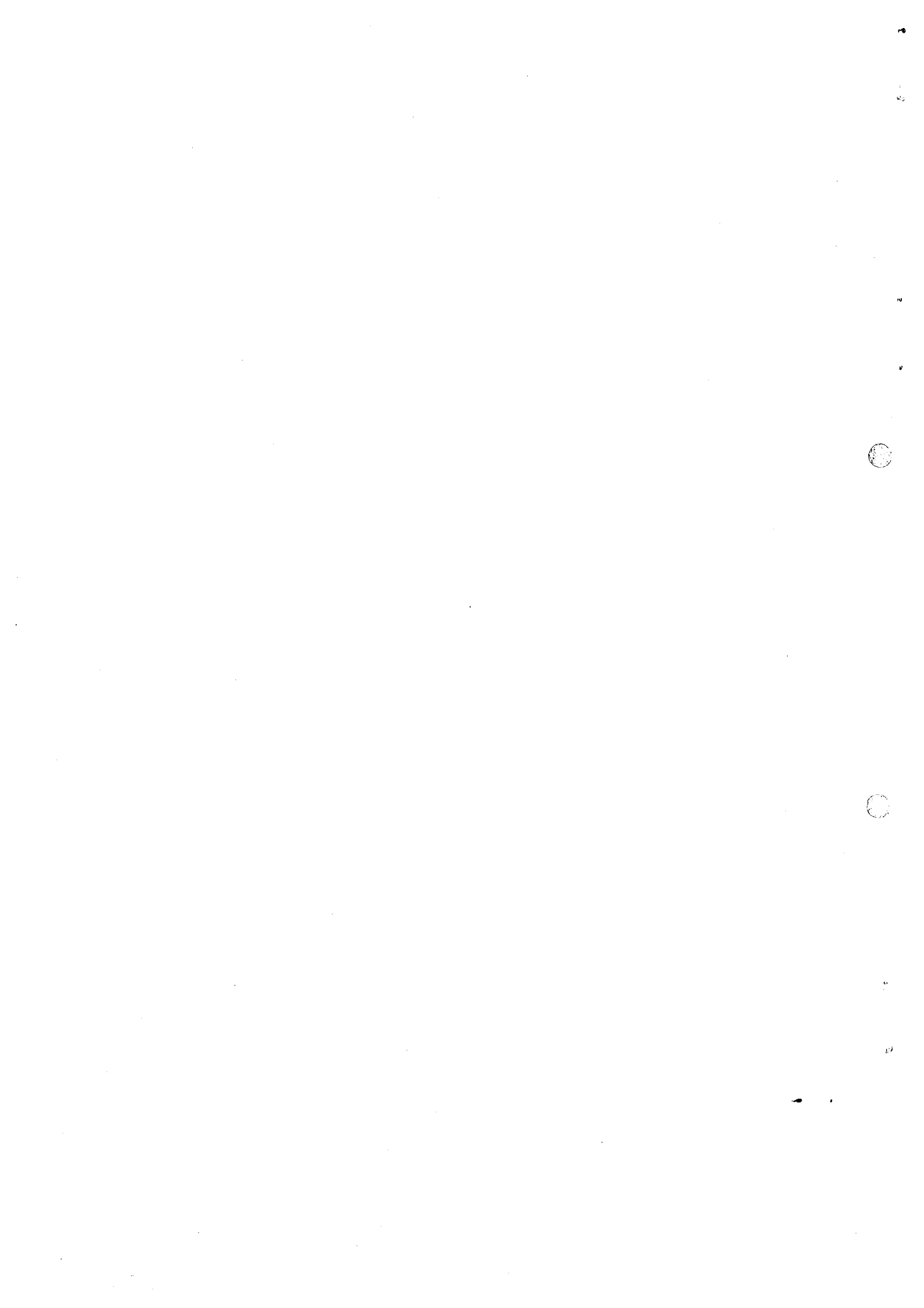

Foreword

ISO (the International Organization for Standardization) is a worldwide federation of national standards bodies (ISO member bodies). The work of preparing International Standards is normally carried out through ISO technical committees. Each member body interested in a subject for which a technical committee has been established has the right to be represented on that committee. International organizations, governmental and non-governmental, in liaison with ISO, also take part in the work. ISO collaborates closely with the International Electrotechnical Commission (IEC) on all matters of electrotechnical standardization.

Draft International Standards adopted by the technical committees are circulated to the member bodies for voting. Publication as an International Standard requires approval by at least 75 % of the member bodies casting a vote.

International Standard ISO 3016 was prepared by Technical Committee ISO/TC 28, *Petroleum products and lubricants*.

This second edition cancels and replaces the first edition (ISO 3016:1974), which has been technically revised.

Annex A forms an integral part of this International Standard.

© ISO 1994

All rights reserved. Unless otherwise specified, no part of this publication may be reproduced or utilized in any form or by any means, electronic or mechanical, including photocopying and microfilm, without permission in writing from the publisher.

International Organization for Standardization
Case Postale 56 • CH-1211 Genève 20 • Switzerland

Printed in Switzerland

Petroleum products — Determination of pour point

WARNING — The use of this International Standard may involve hazardous materials, operations and equipment. This standard does not purport to address all of the safety problems associated with its use. It is the responsibility of the user of this standard to establish appropriate safety and health practices and determine the applicability of regulatory limitations prior to use.

1 Scope

This International Standard specifies a method for the determination of the pour point of petroleum products. A separate procedure suitable for the determination of the lower pour point of fuel oils, heavy lubricant base stock, and products containing residual fuel components is also described.

NOTE 1 A method for the pour point of crude oils is under development. The pour point of crude oils may be determined by the general procedure described in this International Standard, but some crude oils may need a modified pretreatment to avoid the loss of volatile material. The precision in this International Standard was derived on a sample matrix that did not include crude oils (see note 5).

2 Definition

For the purposes of this International Standard, the following definition applies.

2.1 pour point: Lowest temperature at which a sample of petroleum product will continue to flow when it is cooled under specified standard conditions.

3 Principle

After preliminary heating, the sample is cooled at a specified rate and examined at intervals of 3 °C for flow characteristics. The lowest temperature at which movement of the sample is observed is recorded as the pour point.

4 Reagents and materials

4.1 Sodium chloride (NaCl), crystals.

4.2 Calcium chloride (CaCl₂), crystals.

4.3 Carbon dioxide (CO₂), solid.

4.4 Coolant liquid: acetone, methanol or petroleum naphtha.

4.5 Wiping fluid: acetone, methanol or ethanol.

5 Apparatus (see figure 1)

5.1 Test jar, cylindrical, of clear glass, flat-bottomed, 33,2 mm to 34,8 mm outside diameter and 115 mm to 125 mm in height. The test jar shall have an inside diameter of 30,0 mm to 32,4 mm, with the constraint that the wall thickness be no greater than 1,6 mm. The jar shall be marked with a line to indicate a contents level 54 mm ± 3 mm above the inside bottom.

5.2 Thermometers, partial immersion type conforming to the specifications given in annex A.

5.3 Cork, to fit the test jar, bored centrally to take the test thermometer.

5.4 Jacket, watertight, cylindrical, metal, flat-bottomed, 115 mm ± 3 mm in depth with inside diameter 44,2 mm to 45,8 mm, and a wall thickness of approximately 1 mm. It shall be supported in a vertical

position in the cooling bath (5.7) so that no more than 25 mm projects out of the cooling medium, and shall be capable of being cleaned.

Dimensions in millimetres

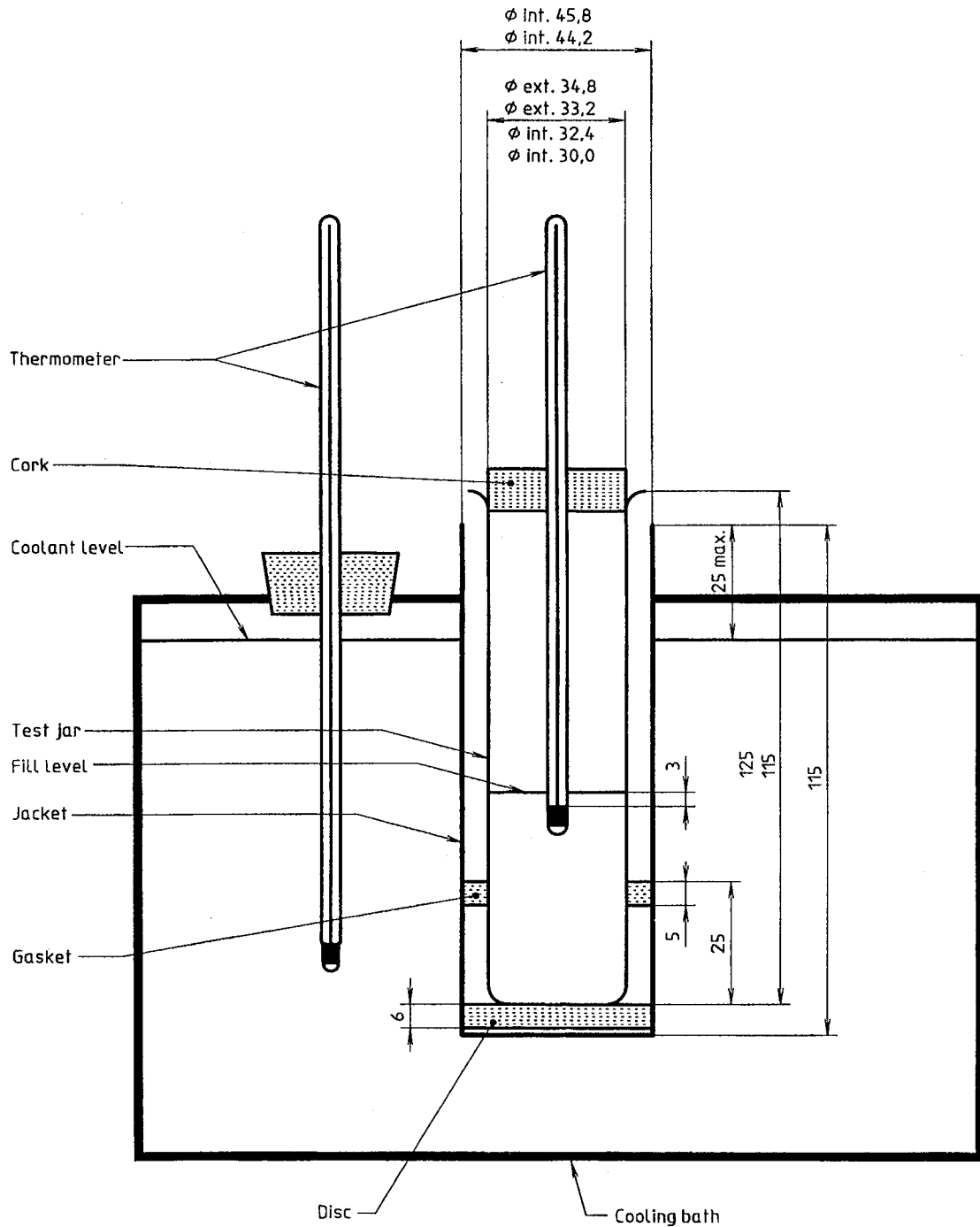

Figure 1 — Apparatus for pour point test

5.5 Disc, of cork or felt approximately 6 mm in thickness, to fit inside the jacket.

5.6 Gasket, ring form, approximately 5 mm in thickness, to fit snugly on the outside of the test jar and loosely inside the jacket. This gasket shall be made of rubber, leather or other suitable material, elastic enough to cling to the test jar and hard enough to hold its shape.

NOTE 2 The purpose of the ring gasket is to prevent the test jar from touching the jacket.

5.7 Cooling bath, of a type suitable for obtaining the required temperatures. The size and shape of the bath are optional, but a support to hold the jacket firmly in a vertical position is essential. The bath temperature shall be monitored by means of the appropriate thermometer (specified in annex A) immersed to the correct immersion depth. For the determination of pour points below 9 °C, two or more baths are required. The required bath temperatures shall be obtained either by refrigeration or by suitable freezing mixtures, and shall be maintained at the desired temperatures $\pm 1,5$ °C.

NOTE 3 The freezing mixtures commonly used are as follows:

For pour-point temperatures down to:

- a) 9 °C: ice and water (can be used to prepare the 0 °C bath in 6.8);
- b) - 12 °C: crushed ice and sodium chloride (4.1) (can be used to prepare the - 18 °C bath in 6.8);
- c) - 27 °C: crushed ice and calcium chloride (4.2) (can be used to prepare the - 33 °C bath in 6.8);
- d) - 57 °C: carbon dioxide (4.3) and coolant liquid (4.4)¹⁾ (can be used to prepare the - 51 °C and - 69 °C baths in 6.8).

5.8 Timing device, capable of measuring up to 30 s with an accuracy of 0,2 s.

6 Procedure

6.1 Pour the sample into the test jar to the level mark. If necessary, heat the sample in a water bath until it is just sufficiently fluid to pour into the test jar.

1) This mixture may be made as follows: in a covered metal beaker chill a suitable amount of coolant liquid (4.4) to - 12 °C, or lower, by means of an ice-salt mixture. Then add enough carbon dioxide (4.3) to the chilled coolant liquid to give the desired temperature. Solid carbon dioxide is commercially available in many areas.

If it is necessary to heat the sample to a temperature greater than 45 °C to effect the transfer to the test jar, or when it is known that a sample has been heated to a temperature higher than 45 °C during the preceding 24 h, or when the thermal history of the sample is not known, keep the sample at room temperature for 24 h before testing it.

6.2 Close the test jar (5.1) with the cork (5.3) carrying the high-cloud-and-pour thermometer or, if the expected pour point is above 36 °C, the melting point thermometer (annex A). Adjust the position of the cork and thermometer so that the cork fits tightly, the thermometer and the test jar are coaxial, and the thermometer bulb is immersed to a depth which places the beginning of the capillary 3 mm below the surface of the sample.

6.3 Subject the sample in the test jar to a preliminary treatment, appropriate to its pour point, in accordance with 6.4 or 6.5.

6.4 Samples having pour points above - 33 °C shall be treated as follows.

6.4.1 Heat the sample without stirring to 9 °C above the expected pour point, or to 45 °C, whichever is greater, in a bath maintained at 12 °C above the expected pour point, but at least 48 °C.

6.4.2 Transfer the test jar to a bath maintained at 24 °C $\pm 1,5$ °C.

6.4.3 When the sample temperature reaches 9 °C above the expected pour point (estimated as a multiple of 3 °C), commence observations for flow in accordance with 6.7.

6.4.4 If the sample has not ceased to flow when the temperature has reached 27 °C, carefully remove the test jar from the bath, wipe the outside surface with a clean cloth moistened with wiping fluid (4.5), and place it in the 0 °C bath (5.7) in accordance with 6.6. Make observations for flow in accordance with 6.7 and cool as specified in the schedule given in 6.8.

6.5 Samples having pour points of - 33 °C and below shall be treated as follows.

6.5.1 Heat the sample without stirring to 45 °C in a bath maintained at 48 °C, and cool to 15 °C in a bath maintained at 6 °C $\pm 1,5$ °C.

6.5.2 When the temperature has reached 15 °C, carefully remove the test jar from the water bath, wipe the outside surface with a clean cloth moistened with wiping fluid (4.5), remove the high-cloud-and-pour thermometer and replace it with the low-cloud-and-pour thermometer (annex A). Place the test jar in the 0 °C bath (6.7) in accordance with 6.6. Successively place the test jar into lower-temperature baths in accordance with the schedule specified in 6.8.

6.5.3 When the temperature reaches 9 °C above the expected pour point, commence observations for flow in accordance with 6.7.

6.6 Ensure that the disc (5.5), gasket (5.6) and the inside of the jacket (5.4) are clean and dry, and place the disc in the bottom of the jacket. The disc and jacket shall have been placed in the cooling medium (see 5.7) a minimum of 10 min before the test jar is inserted. Place the gasket around the test jar approximately 25 mm from the bottom, and insert the test jar into the jacket. With the exception of the baths at 24 °C and 6 °C, never place a test jar directly into the cooling medium.

6.7 Carry out observations for flow.

6.7.1 At each thermometer reading that is a multiple of 3 °C below the temperature of the first observation, remove the test jar from the bath or jacket, as applicable, and tilt it just sufficiently to ascertain whether there is movement in the sample in the test jar. The complete operation of test jar removal, observation of the sample for flow, and return of the test jar to the bath shall not exceed 3 s.

6.7.2 Continue observations at each thermometer reading that is a multiple of 3 °C below the temperature of the first observation.

Take great care not to disturb the mass of sample or to permit the thermometer to shift in the sample after the sample has cooled sufficiently to allow for the formation of wax crystals, as any disturbance of the spongy network of wax crystals will lead to low and erroneous results.

NOTE 4 At low temperatures, condensed moisture may limit visibility. This can be removed by wiping the outside surface of the test jar with a clean cloth moistened with wiping fluid (4.5) close to the bath temperature.

6.7.3 As soon as the sample does not flow when tilted, hold the test jar in a horizontal position for 5 s, as measured by the timing device (5.8), and observe carefully. If the sample shows any movement, replace

the test jar immediately in the bath or jacket, as applicable, and repeat the observation at the next temperature, 3 °C lower.

6.7.4 Continue in this manner until a temperature is reached when the sample shows no movement when the test jar is held in a horizontal position for 5 s. Record the observed reading of the thermometer.

6.8 If the sample has not ceased to flow when its temperature has reached 9 °C, transfer it to the next lower temperature bath, and similarly at -6 °C, -24 °C and -42 °C in accordance with the following schedule:

- a) sample is at +9 °C, move to -18 °C bath;
- b) sample is at -6 °C, move to -33 °C bath;
- c) sample is at -24 °C, move to -51 °C bath;
- d) sample is at -42 °C, move to -69 °C bath.

6.9 To determine compliance with existing obsolescent specifications having pour-point limits at temperatures not divisible by 3 °C, it is acceptable practice to conduct the pour-point measurement according to the following schedule.

Begin to examine the appearance of the sample when the temperature of the sample is 9 °C above the specification pour point. Continue observations at 3 °C intervals in accordance with 6.7 and 6.8 until the specification temperature is reached. Report the sample as passing or failing the specification limit.

6.10 For fuel oils, heavy lubricant base stock and products containing residual fuel components, the result obtained by the procedure given in 6.1 to 6.8 is the upper (maximum) pour point. If required, determine the lower (minimum) pour point by heating the sample while stirring to 105 °C, pouring it into the jar, and determining the pour point as given in 6.2 to 6.8.

6.11 If automatic testing instruments are used, the user shall ensure that all of the manufacturer's instructions for calibration, adjustment and operation of the instrument are followed. As the precision of automatic pour-point testers has not been determined, in any case of dispute, the pour point shall be determined by the manual method described herein and shall be considered as the reference test.

7 Expression of results

Add 3 °C to the temperature recorded in 6.7.4 or 6.10 and report this as the pour point, or lower pour point, as applicable.

8 Precision

8.1 Repeatability

The difference between successive test results obtained by the same operator with the same apparatus under constant operating conditions on identical test material would, in the long run, in the normal and correct operation of the test method, exceed 3 °C only in one case in 20. Differences greater than this should be considered suspect.

8.2 Reproducibility

The difference between two single and independent results, obtained by different operators working in different laboratories on nominally identical test material would, in the long run, in the normal and correct operation of the test method, exceed 6 °C only in one case in 20. Differences greater than this should be considered suspect.

NOTE 5 The precision statements were prepared with data on ten new (unused) mineral oil-based lubricants and

16 assorted fuel oils tested by 12 co-operators. The mineral oil-based lubricants had pour points ranging from - 48 °C to - 6 °C, while the fuel oils had pour points ranging from - 33 °C to + 51 °C. The following precision data was obtained:

	Mineral oils, lubricants	Fuel oils
95 % confidence:		
Repeatability, °C	2,87	2,52
Reproducibility, °C	6,43	6,59

9 Test report

The test report shall contain at least the following information:

- sufficient details for complete identification of the product tested;
- a reference to this International Standard;
- the result of the test (see clause 7);
- any deviation, by agreement or otherwise, from the procedures specified (see clause 6);
- the date of the test;
- whether the test was determined by an automatic instrument.

Annex A (normative)

Thermometer specifications

Table A.1 gives the specifications for the partial immersion liquid-in-glass thermometers required for this International Standard. Thermometers ASTM 6C/IP 2C (low cloud and pour), ASTM 5C/IP 1C (high cloud and pour), and ASTM 61C/IP 63C (melting point) meet these requirements.

Table A.1 — Thermometer specifications

		Low cloud and pour	High cloud and pour	Melting point
Range	°C	− 80 to + 20	− 38 to + 50	32 to 127
Immersion	mm	76	108	79
Graduation at each	°C	1	1	0,2
Longer lines at each	°C	5	5	1
Figured at each	°C	10	10	2
Scale error, max	°C	1 down to − 33 2 below − 33	0,5	0,2
Expansion chamber to permit heating to	°C	60	100	150
Overall length	mm	230 ± 5	230 ± 5	380 ± 5
Stem diameter	mm	6 to 8	6 to 8	6 to 8
Bulb length	mm	7,0 to 10	7,0 to 10	18 to 28
Bulb diameter	mm	5,0 to stem	5,5 to stem	5,0 to 6,0
Distance from bottom of bulb to line at	°C	− 70	− 38	32
	mm	100 to 120	120 to 130	105 to 115
Length of scale/range	mm	70 to 100	65 to 85	200 to 240

NOTES

6 The emergent stem temperature is 21 °C throughout the scale range.

7 Since separation of liquid column thermometers occasionally occurs and may escape detection, thermometers should be checked immediately prior to the test and used only if they prove accurate within ± 1 °C (for example ice point).





ICS 75.080.00

Descriptors: petroleum products, tests, low temperature tests, determination, solidification point, test equipment.

Price based on 6 pages
