

INTERNATIONAL STANDARD

ISO 3011

Third edition
1997-04-15

Rubber- or plastics-coated fabrics — Determination of resistance to ozone cracking under static conditions

*Supports textiles revêtus de caoutchouc ou de plastique — Détermination
de la résistance aux craquelures dues à l'ozone dans des conditions
statiques*

This material is reproduced from ISO documents under International Organization for Standardization (ISO) Copyright License number IHS/ICC/1996. Not for resale. No part of these ISO documents may be reproduced in any form, electronic retrieval system or otherwise, except as allowed in the copyright law of the country of use, or with the prior written consent of ISO (Case postale 56, 1211 Geneva 20, Switzerland, Fax +41 22 734 10 79), IHS or the ISO Licensor's members.



Reference number
ISO 3011:1997(E)

ISO 3011:1997(E)**Foreword**

ISO (the International Organization for Standardization) is a worldwide federation of national standards bodies (ISO member bodies). The work of preparing International Standards is normally carried out through ISO technical committees. Each member body interested in a subject for which a technical committee has been established has the right to be represented on that committee. International organizations, governmental and non-governmental, in liaison with ISO, also take part in the work. ISO collaborates closely with the International Electrotechnical Commission (IEC) on all matters of electrotechnical standardization.

Draft International Standards adopted by the technical committees are circulated to the member bodies for voting. Publication as an International Standard requires approval by at least 75 % of the member bodies casting a vote.

International Standard ISO 3011 was prepared by Technical Committee ISO/TC 45, *Rubber and rubber products*.

This third edition cancels and replaces the second edition (ISO 3011:1981), which has been technically revised.

© ISO 1997

All rights reserved. Unless otherwise specified, no part of this publication may be reproduced or utilized in any form or by any means, electronic or mechanical, including photocopying and microfilm, without permission in writing from the publisher.

International Organization for Standardization
Case postale 56 • CH-1211 Genève 20 • Switzerland
Internet central@iso.ch
X.400 c=ch; a=400net; p=iso; o=isocs; s=central

Printed in Switzerland

Rubber- or plastics-coated fabrics — Determination of resistance to ozone cracking under static conditions

WARNING — Persons using this standard should be familiar with normal laboratory practice. This standard does not purport to address all of the safety problems, if any, associated with its use. It is the responsibility of the user to establish appropriate safety and health practices and to ensure compliance with any national regulatory conditions.

1 Scope

This International Standard specifies a method for the determination of the resistance of fabrics coated with rubber or plastics to ozone cracking under static conditions.

The test is designed to determine the relative resistance to cracking of fabric coated with rubber or plastics when exposed under static strain to air containing ozone in the absence of direct sunlight.

Like all ageing tests, it should be considered as a means of comparing articles of the same composition and destined for the same application, but not as an absolute criterion. It is preferable to limit the significance of the test by considering it only as a means of control when a fabric attains a resistance superior to a threshold given in comparison with a certain type of degradation.

Taking these remarks into account, the results obtained at the time of test cannot be taken as a prediction of the length of life of the product.

2 Normative references

The following standards contain provisions which, through reference in this text, constitute provisions of this International Standard. At the time of publication, the editions indicated were valid. All standards are subject to revision, and parties to agreements based on this International Standard are encouraged to investigate the possibility of applying the most recent editions of the standards listed below. Members of IEC and ISO maintain registers of currently valid International Standards.

ISO 1431-1:1989, *Rubber, vulcanized or thermoplastic — Resistance to ozone cracking — Part 1: Static strain test.*

ISO 2286-1:—¹⁾, *Rubber- or plastics-coated fabrics — Determination of roll characteristics — Part 1: Methods for determination of the length, width and net mass of a roll.*

3 Principle

Test pieces are exposed to ozone under specified conditions. The effects of the ozone are assessed by measurement of the time at which the first crack appears or of the time of exposure during which no cracks appear, as appropriate.

¹⁾ To be published. (Revision, in parts, of ISO 2286:1986)

4 Apparatus

4.1 **Test chamber and ancillary apparatus**, as specified in ISO 1431-1.

4.2 **Test piece holder**, comprising a mandrel and clamps (see figure 1).

The diameter of the mandrel shall be 2 times, 5 times, 10 times or 20 times the thickness of the test piece, as agreed between the interested parties, but it shall not be less than 0,8 mm. The mandrel and clamps shall be made of a material that does not absorb ozone, for example stainless steel, polymethacrylate, wood coated with a lacquer that does not absorb ozone, or duralumin, and shall have a smooth finish.

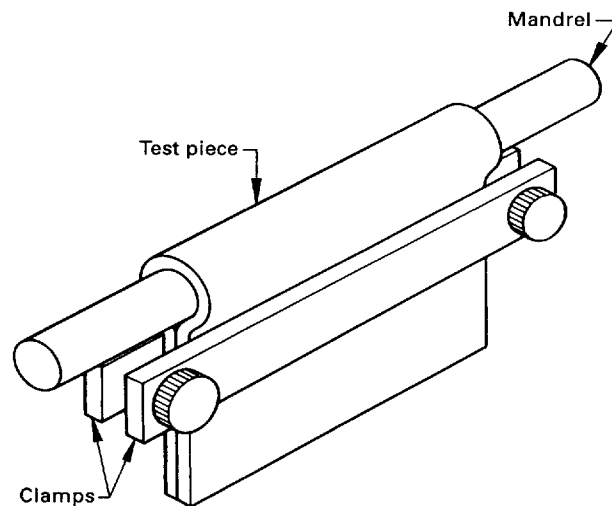

Figure 1 — Test piece holder

5 Test pieces

5.1 Type

The test pieces shall be of sufficient size to permit proper evaluation of the exposed surface after test, and satisfactory comparison of different test pieces. The preferred size is 25 mm wide and 100 mm long.

5.2 Selection

Test pieces shall be taken at least 50 mm from the selvedge of a sample which is as representative as possible of the whole consignment, in accordance with ISO 2286-1.

5.3 Number

Three test pieces in each direction of the fabric for each coated face shall be prepared.

6 Time intervals before testing

Unless otherwise specified for technical reasons, the following requirements apply:

For non-product tests, the minimum time between manufacture and commencement of testing shall be 16 h. The maximum time between manufacture and testing shall be 4 weeks.

For product tests, the minimum time between manufacture and commencement of testing shall be 120 h, during which period the test pieces shall be stored at the standard laboratory temperature. The maximum time between manufacture and testing shall be three months, and the maximum time between receipt of the product by the test laboratory and testing shall be two months.

For evaluations intended to be comparable, the tests shall, as far as possible, be carried out after the same time interval and at the same temperature.

7 Test conditions

7.1 Ozone concentration

The ozone concentration shall comply with the requirements of subclause 8.1 of ISO 1431-1:1989.

7.2 Temperature

The temperature of test shall comply with the requirements of subclause 8.2 of ISO 1431-1:1989.

7.3 Mounting of test pieces under stress and conditioning

The test piece shall be wrapped round the mandrel of the test piece holder with the surface under test on the outside and the ends of the test piece held by the clamps tightly enough for the mandrel just to be able to revolve freely in the test piece.

Several test pieces of the same thickness may be wrapped around a single mandrel.

Where multi-ply coatings are to be tested, they may be tested as single-faced fabrics, vulcanized under the same conditions as the final multi-ply product. Where this is not practical, then the rubber compound shall be tested in accordance with ISO 1431-1.

The test piece, assembled on its mandrel, shall be conditioned in a substantially ozone- and draught-free atmosphere at the standard laboratory temperature for 48 h, after which the test piece shall be placed in the test chamber.

8 Procedure

WARNING — Ozone is highly toxic. Appropriate measures shall be taken to minimize the exposure of the operator.

Carry out the procedure in accordance with clause 9 of ISO 1431-1:1989, disposing the test pieces in the chamber so that they are at least 10 mm from each other and from the wall of the chamber.

Examine the test pieces under a magnification of $\times 7$.

9 Test report

The test report shall include the following particulars:

- a) a reference to this International Standard;
- b) all details necessary for identification of the sample;

- c) the thickness of the test piece and the mandrel diameter;
- d) the ozone concentration and the method of measuring it;
- e) the temperature of test;
- f) the time, in hours, at which the first crack appeared on each test piece or the time of exposure during which no cracks appeared, as appropriate.

ICS 59.080.40

Descriptors: fabrics, coated fabrics, fabrics coated with rubber, fabrics coated with plastics, tests, artificial ageing tests, cracking tests, determination, chemical resistance, ozone.

Price based on 4 pages
