

INTERNATIONAL STANDARD

ISO 2951

Second edition
2012-06-01

Rubber, vulcanized or thermoplastic — Determination of insulation resistance

*Caoutchouc vulcanisé ou thermoplastique — Détermination de la
résistance d'isolement*



Reference number
ISO 2951:2012(E)

© ISO 2012

ISO 2951:2012(E)



COPYRIGHT PROTECTED DOCUMENT

© ISO 2012

All rights reserved. Unless otherwise specified, no part of this publication may be reproduced or utilized in any form or by any means, electronic or mechanical, including photocopying and microfilm, without permission in writing from either ISO at the address below or ISO's member body in the country of the requester.

ISO copyright office
Case postale 56 • CH-1211 Geneva 20
Tel. + 41 22 749 01 11
Fax + 41 22 749 09 47
E-mail copyright@iso.org
Web www.iso.org

Published in Switzerland

Contents		Page
Foreword		iv
Introduction		v
1 Scope		1
2 Normative references		1
3 Terms and definitions		1
4 Test equipment		1
5 Electrodes		1
5.1 General		1
5.2 Conducting-paint electrodes (for flat plates, tubes and rods)		2
5.3 Bar electrodes (for thin sheets and tapes)		2
6 Test pieces		2
6.1 Test pieces for conducting-paint electrodes		2
6.2 Test pieces for bar electrodes		2
6.3 Attachment of electrodes		2
6.4 Conditioning		2
6.5 Number of test pieces		2
7 Procedure		3
8 Expression of results		3
8.1 Test pieces using conducting-paint electrodes		3
8.2 Test pieces using bar electrodes		3
9 Test report		3
Annex A (informative) Cleaning and mounting of test pieces		7
Bibliography		8

ISO 2951:2012(E)

Foreword

ISO (the International Organization for Standardization) is a worldwide federation of national standards bodies (ISO member bodies). The work of preparing International Standards is normally carried out through ISO technical committees. Each member body interested in a subject for which a technical committee has been established has the right to be represented on that committee. International organizations, governmental and non-governmental, in liaison with ISO, also take part in the work. ISO collaborates closely with the International Electrotechnical Commission (IEC) on all matters of electrotechnical standardization.

International Standards are drafted in accordance with the rules given in the ISO/IEC Directives, Part 2.

The main task of technical committees is to prepare International Standards. Draft International Standards adopted by the technical committees are circulated to the member bodies for voting. Publication as an International Standard requires approval by at least 75 % of the member bodies casting a vote.

Attention is drawn to the possibility that some of the elements of this document may be the subject of patent rights. ISO shall not be held responsible for identifying any or all such patent rights.

ISO 2951 was prepared by Technical Committee ISO/TC 45, *Rubber and rubber products*, Subcommittee SC 2, *Testing and analysis*.

This second edition cancels and replaces the first edition (ISO 2951:1974), which has been technically revised as follows:

- the title and scope have been modified to include thermoplastic rubbers;
- the normative references have been updated;
- the instructions in old subclause 6.2 (now 5.3) concerning rigid materials have been deleted;
- the number of test pieces tested is now “more than three” (see 6.5), as opposed to “three” in the previous edition;
- the test report has been updated.

Introduction

This International Standard specifies an empirical method that gives a value for insulation resistance which includes, without discrimination, both volume and surface resistance. This value can be used for the comparison of the quality of different insulating rubbers. For general principles regarding measuring resistance, general effects of temperature and humidity, applied voltage and time of electrification, see IEC 60093 and IEC 60167^[3].

Rubber, vulcanized or thermoplastic — Determination of insulation resistance

1 Scope

This International Standard specifies a method for the determination of the insulation resistance of vulcanized and thermoplastic rubbers without discrimination between the volume and surface resistances involved. This method should only be used for test pieces with a resistance greater than $10^8 \Omega$.

NOTE Methods of test for test pieces with a lower resistance are described in ISO 1853 and ISO 2878.

Because the test pieces are simply and easily prepared, this method is particularly useful for rapidly determining values which will give a general indication of quality when great accuracy is not required.

2 Normative references

The following referenced documents are indispensable for the application of this document. For dated references, only the edition cited applies. For undated references, the latest edition of the referenced document (including any amendments) applies.

IEC 60093, *Methods of test for volume resistivity and surface resistivity of solid electrical insulating materials*

3 Terms and definitions

For the purposes of this document, the following terms and definitions apply.

3.1

insulation resistance

<between two electrodes which are in contact with, or embedded in, a test piece> ratio of the direct voltage applied to the electrodes to the total current between them at a given time after the application of that voltage

NOTE It is dependent upon both the volume and surface resistances of the test piece and is a function of the shape of the test piece.

4 Test equipment

The insulation resistance shall be determined either by a bridge method or by measuring the current and voltage. Brief descriptions of suitable equipment are given in IEC 60093.

Suitable equipment shall be provided to supply a voltage of (500 ± 10) V d.c., which is steady enough so that the charging current appearing when the voltage varies is negligible compared with the current flowing through the test piece.

5 Electrodes

5.1 General

The electrodes shall be made of such a material that they will not corrode under the conditions of test or react with the material being tested. Suitable electrodes are described in 5.2 and 5.3.

ISO 2951:2012(E)

5.2 Conducting-paint electrodes (for flat plates, tubes and rods)

Conducting paint such as conductive silver or colloidal graphite with a surface resistance of less than 100 Ω may be used as an electrode material. The liquid phase of the conducting paint shall be of such a nature that it will not have any effect on the insulation resistance to be measured.

Apply two equidistant strips of conducting paint approximately 1 mm wide around tubes and rods so that the nearest edges are $(10 \pm 0,5)$ mm apart.

NOTE This can be easily done by mounting the tube or rod in a lathe and rotating it against a small brush or drawing pen containing the paint.

This type of electrode may also be used on plate test pieces. In this case, the electrodes shall be two parallel strips of conducting paint approximately 1 mm wide spaced $(10 \pm 0,5)$ mm apart, the total length of each electrode being (100 ± 1) mm.

Figures 1 and 2 illustrate this type of electrode.

5.3 Bar electrodes (for thin sheets and tapes)

Metal bar clamps measuring about 10 mm \times 10 mm \times 50 mm which are spaced $(25 \pm 0,5)$ mm apart (see Figure 3) are suitable electrodes for thin sheet material (usually 1 mm or less in thickness) and for flexible tapes. The bar electrodes shall be mounted by means of insulating parts on a metal support to be used as a guard in the measurement of resistance [see Figure 3 a)]. Alternatively, the electrodes may be supported by the test piece or their connections to the insulated terminals [see Figure 3 b)].

6 Test pieces

6.1 Test pieces for conducting-paint electrodes

For measurements with conducting-paint electrodes, the test pieces shall be rectangular sheets having a size of at least 60 mm \times 150 mm (see Figure 1), or rods or tubes at least 60 mm long (see Figure 2).

6.2 Test pieces for bar electrodes

For measurements with bar electrodes, the test pieces in the form of tapes or thin sheets shall be 26 mm or less in width and at least 50 mm long [see Figures 3 a) and 3 b)].

6.3 Attachment of electrodes

The electrodes shall be attached to the test pieces before conditioning.

6.4 Conditioning

Prior to the test, the test piece shall be conditioned, avoiding the application of any stress or strain by bending, twisting or compression, for at least 16 h at (23 ± 2) °C and (50 ± 5) % relative humidity or (27 ± 2) °C and (65 ± 5) % relative humidity.

The same temperature and humidity shall be used throughout any one test or series of tests intended to be comparable.

6.5 Number of test pieces

At least three test pieces shall be used.

7 Procedure

7.1 If necessary, clean the test piece (see Clause A.1 for guidance) and mount it (see Clause A.2 for guidance). Measure the resistance of each test piece individually. The measurement shall be made while the test piece is still in the conditioning atmosphere.

7.2 Measure the resistance with suitable equipment (see Clause 4) having the required sensitivity and an accuracy of $\pm 5\%$. Unless otherwise specified, the applied voltage shall be (500 ± 10) V, and the time of electrification 1 min (see IEC 60093).

8 Expression of results

8.1 Test pieces using conducting-paint electrodes

The insulation resistance, R_{100} , for a standard 100 mm electrode length is calculated using the formula

$$R_{100} = \frac{L}{100} R_x$$

where

R_x is the measured insulation resistance, in megaohms;

L is the measured length of the electrode, in millimetres.

8.2 Test pieces using bar electrodes

The insulation resistance, R_{25} , for a standard 25 mm electrode length is calculated using the formula

$$R_{25} = \frac{W}{25} R_x$$

where

R_x is the measured insulation resistance, in megaohms;

W is the measured width of the test piece, in millimetres.

9 Test report

The test report shall include the following information:

a) sample details:

- 1) a full description of the sample and its origin,
- 2) the method of preparation of the test pieces from the sample, for example moulded or cut;

b) test method:

- 1) a full reference to the test method used, i.e. the number of this International Standard,
- 2) the type of test piece used;

c) test details:

- 1) the laboratory temperature and humidity,
- 2) the number of test pieces used,

ISO 2951:2012(E)

- 3) the time, temperature and humidity of conditioning prior to the test,
 - 4) the type of electrode used, including the nature of the conducting paint, if used,
 - 5) details of any test piece cleaning procedure used,
 - 6) the test voltage,
 - 7) the time of electrification,
 - 8) details of any procedure not specified in this International Standard;
- d) test results:
- 1) the individual test results (i.e. R_{100} or R_{25} values), in megaohms,
 - 2) the median value of the insulation resistance, in megaohms;
- e) the date(s) of the test.

Dimensions in millimetres

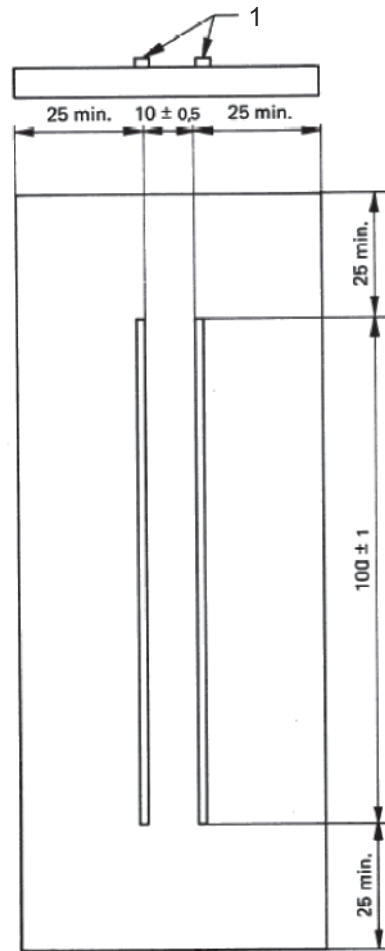

Key

1 conducting-paint electrodes (approximately 1 mm wide)

Figure 1 — Plate test piece with conducting-paint electrodes

Dimensions in millimetres

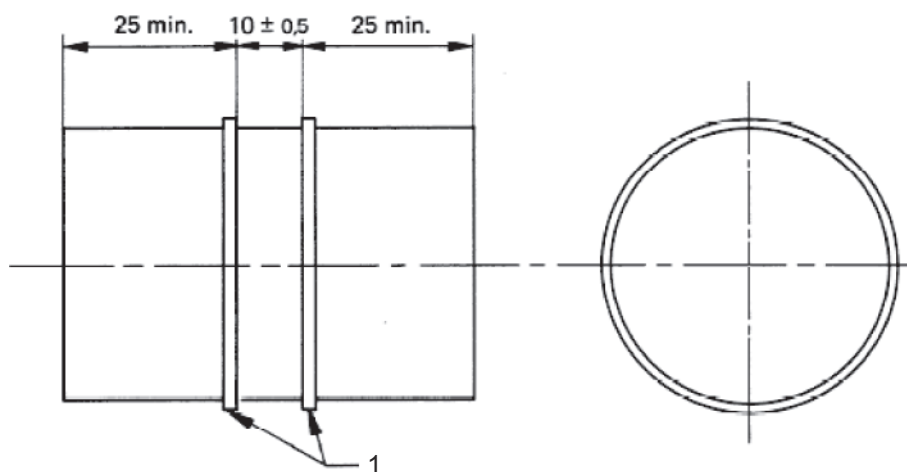

Key

1 conducting-paint electrodes (approximately 1 mm wide)

Figure 2 — Tube or rod test piece with conducting-paint electrodes

ISO 2951:2012(E)

Dimensions in millimetres

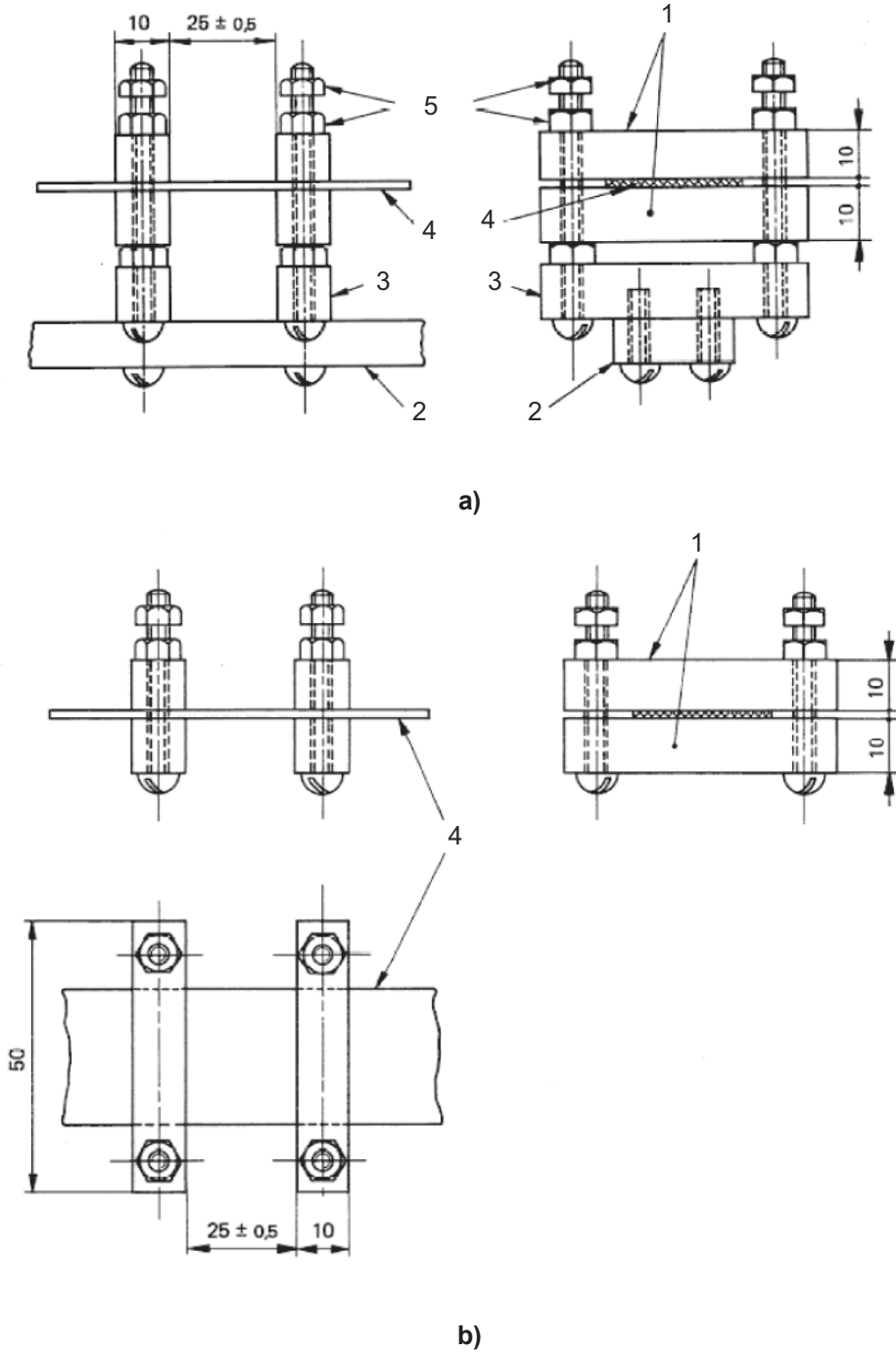

Key

- 1 metal electrodes
- 2 metal support and guard
- 3 insulating material
- 4 test piece
- 5 nuts

Figure 3 — Bar electrodes for tapes or thin sheet material

Annex A (informative)

Cleaning and mounting of test pieces

A.1 Cleaning

In many cases, it is desirable to test the material in the condition in which it is to be used after handling and processing. In this event, the test pieces should not be cleaned. If cleaning is desired, the surfaces of the test pieces should be cleaned before conditioning with an alcohol and ether mixture or other suitable solvent which does not materially affect the resistance of the rubber and, thereafter, the surfaces should not be handled with bare fingers (acetate rayon gloves are recommended).

A.2 Mounting

In mounting the test pieces for measurement, it is important that there be no conducting path between the electrodes other than those associated with the test piece. The supporting material should have a resistance greater than $10^{12} \Omega$. When the mounting supports require guarding, this should be done in accordance with the principles given in IEC 60093.

ISO 2951:2012(E)

Bibliography

- [1] ISO 1853, *Conducting and dissipative rubbers, vulcanized or thermoplastic — Measurement of resistivity*
- [2] ISO 2878, *Rubber, vulcanized or thermoplastic — Antistatic and conductive products — Determination of electrical resistance*
- [3] IEC 60167, *Methods of test for the determination of the insulation resistance of solid insulating materials*

ISO 2951:2012(E)

ICS 83.060

Price based on 8 pages