

---

---

## Rubber hoses and hose assemblies for bulk fuel delivery by truck — Specification

*Tuyaux en caoutchouc et assemblages de tuyaux pour livraison en  
vrac d'hydrocarbures liquides par camions-citernes — Spécifications*





**COPYRIGHT PROTECTED DOCUMENT**

© ISO 2014

All rights reserved. Unless otherwise specified, no part of this publication may be reproduced or utilized otherwise in any form or by any means, electronic or mechanical, including photocopying, or posting on the internet or an intranet, without prior written permission. Permission can be requested from either ISO at the address below or ISO's member body in the country of the requester.

ISO copyright office  
Case postale 56 • CH-1211 Geneva 20  
Tel. + 41 22 749 01 11  
Fax + 41 22 749 09 47  
E-mail [copyright@iso.org](mailto:copyright@iso.org)  
Web [www.iso.org](http://www.iso.org)

Published in Switzerland

# Contents

	Page
Foreword .....	iv
<b>1 Scope</b> .....	<b>1</b>
<b>2 Normative references</b> .....	<b>1</b>
<b>3 Terms and definitions</b> .....	<b>2</b>
<b>4 Classification</b> .....	<b>2</b>
<b>5 Materials and construction</b> .....	<b>2</b>
<b>6 Dimensions</b> .....	<b>2</b>
6.1 Nominal bore, internal diameter, outside diameter and their tolerances, service reeling diameter and minimum bend radius .....	2
6.2 Concentricity .....	3
6.3 Tolerance on length .....	3
6.4 Minimum thickness of lining and cover .....	3
<b>7 Physical properties</b> .....	<b>3</b>
7.1 Rubber compounds .....	3
7.2 Finished hoses and hose assemblies .....	4
<b>8 Electrical resistance</b> .....	<b>5</b>
8.1 General .....	5
8.2 M-grade .....	5
8.3 Ω-grade .....	6
<b>9 Types of test</b> .....	<b>6</b>
<b>10 Design verification testing (type testing)</b> .....	<b>6</b>
<b>11 Marking</b> .....	<b>6</b>
11.1 Hoses .....	6
11.2 Hose assemblies .....	7
<b>Annex A (normative) Method of test for strength of adhesion between components</b> .....	<b>8</b>
<b>Annex B (normative) Method of test for flexibility at 20 °C</b> .....	<b>9</b>
<b>Annex C (normative) Method of test for flammability</b> .....	<b>10</b>
<b>Annex D (normative) Test method for security of coupling attachment</b> .....	<b>12</b>
<b>Annex E (normative) Tests to be carried out as part of design verification (type) and routine testing</b> .....	<b>13</b>
<b>Annex F (informative) Recommended tests for production acceptance testing</b> .....	<b>14</b>
<b>Bibliography</b> .....	<b>15</b>

## Foreword

ISO (the International Organization for Standardization) is a worldwide federation of national standards bodies (ISO member bodies). The work of preparing International Standards is normally carried out through ISO technical committees. Each member body interested in a subject for which a technical committee has been established has the right to be represented on that committee. International organizations, governmental and non-governmental, in liaison with ISO, also take part in the work. ISO collaborates closely with the International Electrotechnical Commission (IEC) on all matters of electrotechnical standardization.

The procedures used to develop this document and those intended for its further maintenance are described in the ISO/IEC Directives, Part 1. In particular the different approval criteria needed for the different types of ISO documents should be noted. This document was drafted in accordance with the editorial rules of the ISO/IEC Directives, Part 2 (see [www.iso.org/directives](http://www.iso.org/directives)).

Attention is drawn to the possibility that some of the elements of this document may be the subject of patent rights. ISO shall not be held responsible for identifying any or all such patent rights. Details of any patent rights identified during the development of the document will be in the Introduction and/or on the ISO list of patent declarations received (see [www.iso.org/patents](http://www.iso.org/patents)).

Any trade name used in this document is information given for the convenience of users and does not constitute an endorsement.

For an explanation on the meaning of ISO specific terms and expressions related to conformity assessment, as well as information about ISO's adherence to the WTO principles in the Technical Barriers to Trade (TBT) see the following URL: Foreword - Supplementary information

The committee responsible for this document is ISO/TC 45, *Rubber and rubber products*, Subcommittee SC 1, *Hoses (rubber and plastics)*.

This fourth edition cancels and replaces the third edition (ISO 2929:2002) which has been revised as specified below.

This minor revision of the third edition (ISO 2929:2002) was required to bring this International Standard up to date. The following changes were made.

- In [Clause 2](#) (Normative references), reference to ISO 1746 (bending tests) has been replaced by ISO 10619-1 as ISO 1746 has been withdrawn and replaced by ISO 10619-1.
- The same editorial changes have been made in the text of the standard wherever necessary and the note in [Clause 6](#) (referring to inside diameters above 80 mm) has been deleted.
- The term “type testing” has been added to [Clause 10](#) and [Annex E](#) as this is now the normative term for this type of test (according to ISO 8330).

# Rubber hoses and hose assemblies for bulk fuel delivery by truck — Specification

**WARNING** — Persons using this International Standard should be familiar with normal laboratory practice. This International Standard does not purport to address all of the safety problems, if any, associated with its use. It is the responsibility of the user to establish appropriate health and safety practices and to ensure compliance with any national regulatory conditions.

## 1 Scope

This International Standard specifies the requirements for two groups of rubber hoses and rubber hose assemblies for loading and discharge of liquid hydrocarbon fuels with a maximum working pressure of 10 bar (1,0 MPa).

Both groups of hoses are designed for:

- a) use with hydrocarbon fuels having an aromatic-hydrocarbon content not exceeding 50 % by volume and containing up to 15 % of oxygenated compounds;
- b) operation within the temperature range of – 30 °C to + 70 °C, undamaged by climatic conditions of – 50 °C to + 70 °C when stored in static conditions.

**NOTE** Hoses for use at temperatures lower than – 30 °C should be the subject of discussion between manufacturer and end user.

This International Standard is not applicable to hoses and hose assemblies for LPG systems, aviation fuel systems, fuel station systems or marine applications.

## 2 Normative references

The following documents, in whole or in part, are normatively referenced in this document and are indispensable for its application. For dated references, only the edition cited applies. For undated references, the latest edition of the referenced document (including any amendments) applies.

ISO 37, *Rubber, vulcanized or thermoplastic — Determination of tensile stress-strain properties*

ISO 188, *Rubber, vulcanized or thermoplastic — Accelerated ageing and heat resistance tests*

ISO 1402, *Rubber and plastics hoses and hose assemblies — Hydrostatic testing*

ISO 10619-1, *Rubber and plastics hoses and tubing — Measurement of flexibility and stiffness — Part 1: Bending tests at ambient temperature*

ISO 1817:2011, *Rubber, vulcanized — Determination of the effect of liquids*

ISO 4649:2010, *Rubber, vulcanized or thermoplastic — Determination of abrasion resistance using a rotating cylindrical drum device*

ISO 4671, *Rubber and plastics hoses and hose assemblies — Methods of measurement of the dimensions of hoses and the lengths of hose assemblies*

ISO 7233, *Rubber and plastics hoses and hose assemblies — Determination of resistance to vacuum*

ISO 7326:2006, *Rubber and plastics hoses — Assessment of ozone resistance under static conditions*

ISO 8031, *Rubber and plastics hoses and hose assemblies — Determination of electrical resistance and conductivity*

ISO 8033, *Rubber and plastics hoses — Determination of adhesion between components*

ISO 8330, *Rubber and plastics hoses and hose assemblies — Vocabulary*

### 3 Terms and definitions

For the purposes of this document, the terms and definitions given in ISO 8330 apply.

### 4 Classification

Hoses are designated as belonging to one of the following groups.

- a) Group D: delivery hose, or, with certain restrictions, for use in low-vacuum applications (see footnote to [Table 3](#)).
- b) Group SD: suction and delivery hose, helix-reinforced.

Both of these groups can be:

- electrically bonded, in which case the hose is designated and marked M-grade; or
- electrically conductive, using a conductive rubber layer, in which case the hose is designated and marked  $\Omega$ -grade.

### 5 Materials and construction

If the hose is mandrel-built, particulate-type release agents shall not be used.

The hose shall be uniform in quality and free from porosity, air-holes, foreign inclusions and other defects.

The hose shall consist of the following:

- a) a lining of rubber resistant to hydrocarbon fuels;
- b) a reinforcement of layers of woven, braided or spirally wound textile material;
- c) an embedded helix reinforcement (group SD only);
- d) two or more low-resistance electrical bonding wires (M-grade only);
- e) an outer cover of rubber, resistant to abrasion, outdoor exposure and hydrocarbon fuels.

### 6 Dimensions

#### 6.1 Nominal bore, internal diameter, outside diameter and their tolerances, service reeling diameter and minimum bend radius

When measured in accordance with ISO 4671, the internal diameter and outside diameter and their tolerances shall conform to the values specified in [Table 1](#).

When determined in accordance with ISO 10619-1, the value of the minimum bend radius shall conform to the values specified in [Table 1](#).

Table 1 — Dimensions

Nominal bore	Internal diameter mm	Tolerance on internal diameter mm	Outside diameter mm	Tolerance on outside diameter mm	Minimum bend radius mm		Minimum external diameter of reeling drum used in service mm	
					Group D	Group SD	Group D	Group SD
19	19,0	±0,5	31,0	±1,0	125	100	250	250
25	25,0		37,0		150	125	300	300
32	32,0		44,0		200	150	400	350
38	38,0		51,0		250	175	500	400
50	50,0	±0,7	66,0	±1,2	300	225	600	500
51	51,0		67,0		300	225	600	500
63	63,0	±0,8	79,0		400	275	800	600
75	75,0		91,0		450	350	900	750
76	76,0		92,0	450	350	900	750	
100	100,0		116,0	600	450	N.A.	N.A.	
101	101,5	±1,6	118,0	600	450	N.A.	N.A.	
150	150,0		170,0	±2,0	900	750	N.A.	N.A.

## 6.2 Concentricity

When determined in accordance with ISO 4671, the concentricity, based on a total indicator reading between the internal diameter and the outside surface of the cover, shall be no greater than 1,0 mm for hoses of nominal bore up to and including 76, and no greater than 1,5 mm for hoses of nominal bore greater than 76.

## 6.3 Tolerance on length

When measured in accordance with ISO 4671, the length of a hose or hose assembly shall be within  $\pm 1\%$  of the required length.

## 6.4 Minimum thickness of lining and cover

When measured in accordance with ISO 4671, the minimum thickness of the lining of all hoses shall be 1,5 mm.

For hoses of nominal bore up to and including 50, the minimum thickness of the cover shall be 1,5 mm.

For hoses of nominal bore greater than 50, the minimum thickness of the cover shall be 2,0 mm.

## 7 Physical properties

### 7.1 Rubber compounds

When determined by the methods listed in [Table 2](#), the physical properties of the compounds used for the lining and cover shall conform to the values specified in [Table 2](#).

Tests shall be carried out either on samples taken from the hose or from separately vulcanized sheets, 2 mm in thickness and vulcanized to the same cured state as the production hoses.

**Table 2 — Physical properties of rubber compound**

Property	Requirement		Test method
	Lining	Cover	
Minimum tensile strength	7,0 MPa	7,0 MPa	ISO 37 (dumb-bell test piece)
Minimum elongation at break	250 %	250 %	ISO 37 (dumb-bell test piece)
Change in volume in fuel	50 %	—	Clause 7 of ISO 1817:2011 (72 h at 40 °C in liquid 3)
	—	100 %	Clause 7 of ISO 1817:2011 (48 h at 40 °C in liquid B)
Maximum abrasion resistance (relative volume loss $\Delta V$ )	—	180 mm <sup>3</sup>	Method A of ISO 4649:2010
Resistance to ageing:			ISO 188 (7 days at 70 °C, air-oven method)
Change in tensile strength from original value	±30 %	±30 %	
Change in elongation at break from original value	±30 %	±30 %	

## 7.2 Finished hoses and hose assemblies

When determined by the methods listed in [Table 3](#), the physical properties of finished hoses and hose assemblies shall conform to the values specified in [Table 3](#).

**Table 3 — Physical properties of finished hoses and hose assemblies**

Property	Requirements	Test method
<b>Hose tests</b>		
Proof pressure	15 bar and no leakage or other signs of weakness	ISO 1402
Change in length (max.):		ISO 1402
at proof test pressure	Group D: 0 % to + 8 % Group SD: 0 % to + 10 %	
at - 0,8 bar (vacuum)	Group SD: - 2 %	
Change in twist at proof test pressure (max.)	8°/m	ISO 1402
Resistance to vacuum (group SD only) at - 0,8 bar for 10 min (see footnote)	No structural damage	ISO 7233
Burst pressure (min.)	40 bar	ISO 1402
Adhesion between components:		
dry (min.)	2,4 N/mm	<a href="#">Annex A (Clause A.1)</a>
after contact with fuel (min.)	1,8 N/mm	<a href="#">Annex A (Clause A.2)</a>
Ozone resistance at 40 °C	No cracking observed under × 2 magnification	ISO 7326:2006, method 3 [relative humidity (55 ± 10) %, ozone concentration (50 ± 5) pphm, elongation 20 %]
NOTE Smaller sizes of group D hose, i.e. of nominal bore 51 and below, may be used for vacuum applications down to - 0,3 bar.		



Table 3 (continued)

Property	Requirements	Test method
Flexibility: at 20 °C	No permanent deformation or visible structural damage, no increase in electrical resistance, no impairment of electrical continuity and shall comply with the proof pressure requirements	<a href="#">Annex B</a>
at – 30 °C		ISO 10619-2
Electrical resistance (max.)	M-grade: $10^2 \Omega/\text{length}$	ISO 8031
	$\Omega$ -grade: $10^6 \Omega/\text{length}$	
Deformation of hose external diameter under bending at minimum bend radius and internal pressure of 0,7 bar (group D only) (max.)	10 %	ISO 10619-1
Flammability test	No burning on removal of the burner flame, no visible glowing and no leakage of fluid	<a href="#">Annex C</a>
Hose assembly tests		
Proof pressure	15 bar and no leakage or other signs of weakness	ISO 1402
Burst pressure (min.)	40 bar	ISO 1402
Electrical resistance (max.)	M-grade: $10^2 \Omega/\text{assembly}$	ISO 8031
	$\Omega$ -grade: $10^6 \Omega/\text{assembly}$	
Security of coupling attachment	No leakage and no movement of the coupling out of the hose	<a href="#">Annex D</a>
NOTE Smaller sizes of group D hose, i.e. of nominal bore 51 and below, may be used for vacuum applications down to – 0,3 bar.		

## 8 Electrical resistance

### 8.1 General

Adequate electrical resistance of hoses and hose assemblies shall be obtained in accordance with [8.2](#) or [8.3](#).

During and after the hydrostatic tests as described in ISO 1402, the electrical continuity of each hose shall be maintained from end to end and electrical continuity of each hose assembly shall be maintained from one coupling to the other.

### 8.2 M-grade

Two low-resistance bonding wires, applied spirally, shall be incorporated into the hose construction.

When attaching fittings to group D hoses, the bonding wires shall be folded into the hose bore, positioned between the lining and the fitting tail and extended by approximately one-third of the length of the fitting tail into the bore.

When attaching fittings to group SD hoses, electrical bonding shall be achieved by using bonding wires as for group D or by using the helix with or without bonding wires attached.

When determined in accordance with ISO 8031, the resistance along the bonding wires in the case of hoses, or the resistance between fittings in the case of hose assemblies, shall not exceed  $1 \times 10^2 \Omega$  per length or assembly. When obtaining electrical continuity by this method, the hose shall be marked with the symbol “M”.

### 8.3 $\Omega$ -grade

In this type of construction, electrically conducting materials shall be incorporated into the hose lining.

When attaching fittings to this type of hose, an adequate connection between the end-fittings and the conductive layer shall be obtained.

When determined in accordance with ISO 8031, the resistance along the conductive lining in the case of hoses, or the resistance between the fittings in the case of hose assemblies, shall not exceed  $1 \times 10^6 \Omega$  per length or assembly. When obtaining electrical resistance by this method, the hose shall be marked with the symbol " $\Omega$ ".

## 9 Types of test

The tests to be carried out as part of design verification and routine testing shall be as specified in [Annex E](#).

Tests for production acceptance testing are given, solely as a recommendation, in [Annex F](#).

Design verification tests (type tests) are those required to confirm that the product meets all the requirements of this International Standard. Routine tests are those that must be carried out on each hose or hose assembly. Production acceptance tests are those carried out on a batch basis.

## 10 Design verification testing (type testing)

Design verification testing shall be performed in order to supply evidence that all the material, construction and test requirements of this International Standard have been met by the method of manufacture and hose design.

Design verification tests shall be reported at least every five years or whenever a change in the method of manufacture or the materials occurs. The number, sizes and groups/grades of hoses shall be selected to cover all the hoses to which design verification applies, and this information shall be stated in the report.

## 11 Marking

### 11.1 Hoses

Each length of hose shall be legibly and durably marked on the outer cover, at intervals of no greater than 2 m, with the following information:

- a) the manufacturer's name or identification, e.g. Man;
- b) the number and year of publication of this International Standard, i.e. ISO 2929:2014;
- c) the group, e.g. D;
- d) the nominal bore, e.g. 38;
- e) the maximum working pressure in bars, e.g. 10;
- f) the conductivity grade, e.g. M;
- g) the quarter and year of manufacture, e.g. 3Q013.

EXAMPLE Man/ISO 2929:2014/group D/38/WP10/M/3Q013.

## 11.2 Hose assemblies

The couplings shall be permanently marked with the following information:

- a) the manufacturer's or assembler's name or identification mark;
- b) the date of assembly.

.....

## Annex A (normative)

### Method of test for strength of adhesion between components

#### A.1 Dry adhesion

Subject the hose to the adhesion test described in ISO 8033 (for group SD hoses, cut out test pieces parallel to the reinforcing helix) and determine the value, in kN/m, of the strength of adhesion:

- a) between lining and reinforcement;
- b) between reinforcement and cover;
- c) between reinforcement layers.

#### A.2 Adhesion after contact with fuel

Cut a length measuring approximately 300 mm from the hose to be tested and seal one end.

Fill this test piece with liquid 3 as specified in ISO 1817:2011 and lightly cap the top.

Condition the test piece at  $(20 \pm 5) ^\circ\text{C}$  for  $(168 \pm 2)$  h.

Determine the strength of adhesion between the components as in [Clause A.1](#).

## Annex B (normative)

### Method of test for flexibility at 20 °C

Coil an empty hose at  $(20 \pm 5)$  °C around a test drum having an external diameter as specified in [Table B.1](#).

Uncoil the hose and check for visible structural damage and permanent deformation.

Check that the electrical continuity is intact.

**Table B.1 — External diameter of drum for flexibility test**

Internal diameter of hose mm	External diameter of test drum mm
19	180
25	230
32	280
38	360
50/51	430
63	460
75/76	460
100/101,5	690

## Annex C (normative)

### Method of test for flammability

**WARNING — Attention is drawn to the need for ensuring that this test is carried out under suitable environmental conditions and that personnel are adequately protected against risk of fire and inhalation of smoke and/or toxic products of combustion.**

#### C.1 Procedure

**NOTE** This test can be carried out using a reference hose of defined nominal bore, preferably 25. The result thereby obtained can then be applied to hoses of this size and larger, provided the construction materials are the same for all of the sizes.

Bend a hose assembly into a U-shape of radius 10 to 15 times the outside diameter, as shown in [Figure C.1](#).

Fill the hose assembly with liquid F as specified in ISO 1817:2011.

Expose the hose assembly to a naked flame from a Bunsen burner having a barrel of inside diameter 10 mm for a period of 3 min, with the airflow to the burner shut off. The distance between the burner and the hose assembly shall be as indicated in [Figure C.1](#).

#### C.2 Assessment

Examine the hose assembly with regard to:

- a) whether it ceases to show flames on removal of the burner flame;
- b) whether any glowing is visible 2 min after removal of the burner flame;
- c) whether there are any visible signs of leakage on completion of the procedure (i.e. after the additional 2 min to check for glowing).

Dimensions in millimetres

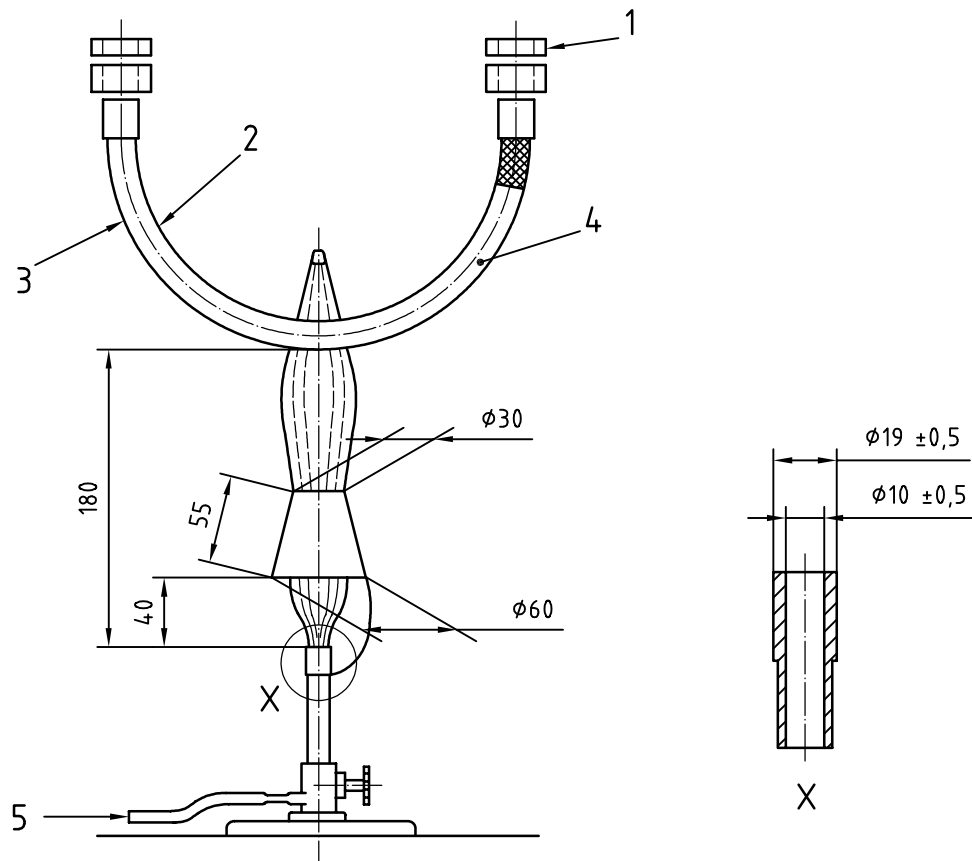

**Key**

- 1 cap
- 2 bend radius 10 to 15 times the outside diameter
- 3 hose assembly
- 4 liquid F as specified in ISO 1817:2011
- 5 propane (LPG) at 50 mbar

**Figure C.1 — Arrangement for flammability test**

## **Annex D** **(normative)**

### **Test method for security of coupling attachment**

#### **D.1 Test piece**

Test one complete hose assembly, of 1 m in length, consisting of hose and end couplings.

#### **D.2 Procedure**

Use water as the test medium. Raise the test pressure to 15 bar and hold for 2 min.

Reduce the applied pressure to 0,7 bar. Increase the pressure to 10 bar, hold for 2 min and examine for leakage. Reduce the applied pressure to 0,7 bar.

Increase the pressure to 15 bar, hold for 2 min and examine for leakage. Reduce the applied pressure to 0,7 bar.

#### **D.3 Assessment**

Examine the hose assembly with regard to:

- a) whether there were any visible signs of leakage during or on completion of the procedure;
- b) whether any movement of the coupling out of the hose has occurred.



## Annex E (normative)

### Tests to be carried out as part of design verification (type) and routine testing

For design verification (type) and routine testing, at least the tests specified in [Table E.1](#) shall be carried out.

**Table E.1 — Tests for design verification (type) and routine testing**

Property	Design verification	Routine
<b>Compound tests</b>		
Tensile strength and elongation at break	X	N.A.
Swelling in fuel	X	N.A.
Abrasion resistance	X	N.A.
Tensile strength and elongation at break after ageing	X	N.A.
<b>Hose tests</b>		
Adhesion, dry	X	N.A.
Adhesion after contact with fuel	X	N.A.
Ozone resistance	X	N.A.
Flexibility at 20 °C	X	N.A.
Flexibility at – 30 °C	X	N.A.
Measurement of internal and external diameters	X	X
Measurement of lining and cover thickness	X	X
Measurement of concentricity	X	X
Vacuum resistance (SD only)	X	N.A.
Electrical resistance	X	X
Proof pressure	X	X
Change in length at proof pressure	X	N.A.
Twist at proof	X	N.A.
Burst pressure	X	N.A.
Bend resistance	X	N.A.
Flammability	X	N.A.
<b>Hose assembly tests</b>		
Electrical resistance	X	X
Proof pressure	X	X
Burst pressure	X	N.A.
Security of coupling attachment	X	N.A.
X = Test required; N.A. = Not applicable.		

## Annex F (informative)

### Recommended tests for production acceptance testing

Tests recommended for production acceptance testing are given in [Table F.1](#).

**Table F.1 — Recommended tests for production acceptance testing**

Property	Production acceptance testing	
	Per batch <sup>a</sup>	Per 10 batches <sup>a</sup>
<b>Compound tests</b>		
Tensile strength and elongation at break	X	N.A.
Swelling in fuel	N.A.	X
Abrasion resistance	N.A.	X
Tensile strength and elongation at break after ageing	N.A.	X
<b>Hose tests</b>		
Adhesion, dry	X	N.A.
Adhesion after contact with fuel	N.A.	X
Ozone resistance	N.A.	X
Flexibility at 20 °C	N.A.	X
Flexibility at – 30 °C	N.A.	X
Measurement of internal and external diameters	N.A.	N.A.
Measurement of lining and cover thickness	N.A.	N.A.
Measurement of concentricity	N.A.	N.A.
Vacuum resistance (SD only)	N.A.	X
Electrical resistance	N.A.	N.A.
Proof pressure	N.A.	N.A.
Change in length at proof pressure	N.A.	X
Change in twist at proof pressure	N.A.	X
Burst pressure	N.A.	X
Bend resistance	N.A.	N.A.
Flammability	N.A.	N.A.
<b>Hose assembly tests</b>		
Electrical resistance	N.A.	N.A.
Proof pressure	N.A.	N.A.
Burst pressure	N.A.	N.A.
Security of coupling attachment	N.A.	N.A.
X = Test required N.A. = Not applicable		
<sup>a</sup> A batch is defined as either 1 000 m of hose or 2 000 kg of lining and/or cover compound.		

## Bibliography

ISO 10619-2, *Rubber and plastics hoses and tubing — Measurement of flexibility and stiffness — Part 2: Bending tests at sub-ambient temperatures*

.....

---

---

**ICS 75.200;83.140.40**

Price based on 15 pages