**Rubber, vulcanized — Determination of
low-temperature characteristics —
Temperature-retraction procedure
(TR test)**

*Caoutchouc vulcanisé — Détermination des caractéristiques à basse
température — Méthode température-retrait (essai TR)*



PDF disclaimer

This PDF file may contain embedded typefaces. In accordance with Adobe's licensing policy, this file may be printed or viewed but shall not be edited unless the typefaces which are embedded are licensed to and installed on the computer performing the editing. In downloading this file, parties accept therein the responsibility of not infringing Adobe's licensing policy. The ISO Central Secretariat accepts no liability in this area.

Adobe is a trademark of Adobe Systems Incorporated.

Details of the software products used to create this PDF file can be found in the General Info relative to the file; the PDF-creation parameters were optimized for printing. Every care has been taken to ensure that the file is suitable for use by ISO member bodies. In the unlikely event that a problem relating to it is found, please inform the Central Secretariat at the address given below.

© ISO 2005

All rights reserved. Unless otherwise specified, no part of this publication may be reproduced or utilized in any form or by any means, electronic or mechanical, including photocopying and microfilm, without permission in writing from either ISO at the address below or ISO's member body in the country of the requester.

ISO copyright office
Case postale 56 • CH-1211 Geneva 20
Tel. + 41 22 749 01 11
Fax + 41 22 749 09 47
E-mail copyright@iso.org
Web www.iso.org

Published in Switzerland

Contents

Page

1	Scope	1
2	Normative references	1
3	Principle	1
4	Apparatus	1
5	Test pieces	2
6	Procedure	4
7	Expression of results	5
8	Test report	5

Foreword

ISO (the International Organization for Standardization) is a worldwide federation of national standards bodies (ISO member bodies). The work of preparing International Standards is normally carried out through ISO technical committees. Each member body interested in a subject for which a technical committee has been established has the right to be represented on that committee. International organizations, governmental and non-governmental, in liaison with ISO, also take part in the work. ISO collaborates closely with the International Electrotechnical Commission (IEC) on all matters of electrotechnical standardization.

International Standards are drafted in accordance with the rules given in the ISO/IEC Directives, Part 2.

The main task of technical committees is to prepare International Standards. Draft International Standards adopted by the technical committees are circulated to the member bodies for voting. Publication as an International Standard requires approval by at least 75 % of the member bodies casting a vote.

Attention is drawn to the possibility that some of the elements of this document may be the subject of patent rights. ISO shall not be held responsible for identifying any or all such patent rights.

ISO 2921 was prepared by Technical Committee ISO/TC 45, *Rubber and rubber products*, Subcommittee SC 2, *Testing and analysis*.

This fourth edition cancels and replaces the third edition (ISO 2921:1997), which has been technically revised.

Rubber, vulcanized — Determination of low-temperature characteristics — Temperature-retraction procedure (TR test)

WARNING — Persons using this International Standard should be familiar with normal laboratory practice. This standard does not purport to address all of the safety problems, if any, associated with its use. It is the responsibility of the user to establish appropriate safety and health practices and to ensure compliance with any national regulatory conditions.

Certain procedures specified in this International Standard may involve the use or generation of substances, or the generation of waste, that could constitute a local environmental hazard. Reference should be made to appropriate documentation on safe handling and disposal after use.

1 Scope

This International Standard specifies a method for the determination of the temperature-retraction characteristics of stretched vulcanized rubber.

NOTE This International Standard does not include thermoplastic rubbers, as many thermoplastic elastomers have a yield point in the range of 5 % to 20 % elongation. This fact may affect the result when carrying out TR tests on thermoplastic rubbers, and the results obtained from such tests should be analysed with caution.

2 Normative references

The following referenced documents are indispensable for the application of this document. For dated references, only the edition cited applies. For undated references, the latest edition of the referenced document (including any amendments) applies.

ISO 23529, *Rubber — General procedures for preparing and conditioning test pieces for physical test methods*

3 Principle

A test piece is stretched at standard laboratory temperature and then cooled to a sufficiently low temperature such that retraction does not occur upon removal of the stretching force. The stretching force is removed and the temperature increased at a uniform rate. The temperatures at which specified percentage retractions occur are determined.

NOTE In addition to the two sizes of standard test piece, other types of test piece cut from products are described. These do not necessarily give the same values of retraction temperature, and comparison between the values obtained using different types of test pieces should be avoided.

4 Apparatus

See Figure 1.

4.1 Bath for coolant, which is insulated and equipped with a stirrer, a thermometer and a device for heating the coolant in accordance with ISO 23529.

4.2 Coolant, which does not affect the rubber material being tested, as prescribed in ISO 23529.

Gases may be employed as the coolant provided the design of the apparatus is such that results obtained using them will duplicate those obtained with liquids.

The following fluids can be used:

- a) for temperatures down to $-60\text{ }^{\circ}\text{C}$, silicone oils of kinematic viscosity about $5\text{ mm}^2/\text{s}$ at ambient temperature, owing to their chemical inertness towards rubbers, their non-flammability and their non-toxicity;
- b) for temperatures down to $-70\text{ }^{\circ}\text{C}$, methanol or ethanol;
- c) for temperatures down to $-120\text{ }^{\circ}\text{C}$, methylcyclohexane cooled by liquid nitrogen (found to be satisfactory with the use of suitable apparatus).

4.3 Rack with test piece holders, equipped with a loading device, holders for one or more test pieces and a locking device for the upper (movable) test piece holders (see Figure 1).

The rack shall be designed to maintain a slight tension (10 kPa to 20 kPa) on the test pieces and to permit them to be stretched up to a maximum of 350 %; the design shall permit the upper test piece holder to be locked into position at the chosen elongation and subsequently released. Means shall be provided to enable the length of the test pieces to be read, at any time during the test, with an accuracy of $\pm 0,25\text{ mm}$ or better.

Alternatively, a series of removable scales graduated to allow the retraction to be read directly as a percentage of the elongation of the frozen rubber with an accuracy of $\pm 0,5\%$ may be used. The movable parts of the apparatus shall be constructed so that the lowest possible friction occurs.

5 Test pieces

5.1 Preparation

Test pieces shall be prepared in general accordance with ISO 23529.

5.2 Types

5.2.1 Standard test piece

The standard test piece shall be a strip with enlarged ends for clamping, with dimensions in accordance with Figure 2. The reference length shall be either 100 mm or 50 mm. The test piece with a reference length of 100 mm is preferred for tests with small elongations and the test piece with a reference length of 50 mm for tests with larger elongations. Test pieces shall be cut with a sharp die from a flat sheet $2\text{ mm} \pm 0,2\text{ mm}$ thick. The sheets may be prepared by moulding or from finished products by cutting and buffing.

The 50 mm test piece can also be used with 50 % elongation if the reading accuracy of the measurement system is $\pm 0,125\text{ mm}$ or better.

5.2.2 Test pieces cut from products

Alternatively, other types of test piece cut from finished rubber products may be used (for example an O-ring with a cross-sectional diameter between 1,5 mm and 4 mm).

5.3 Number

At least three test pieces shall be used for each test.

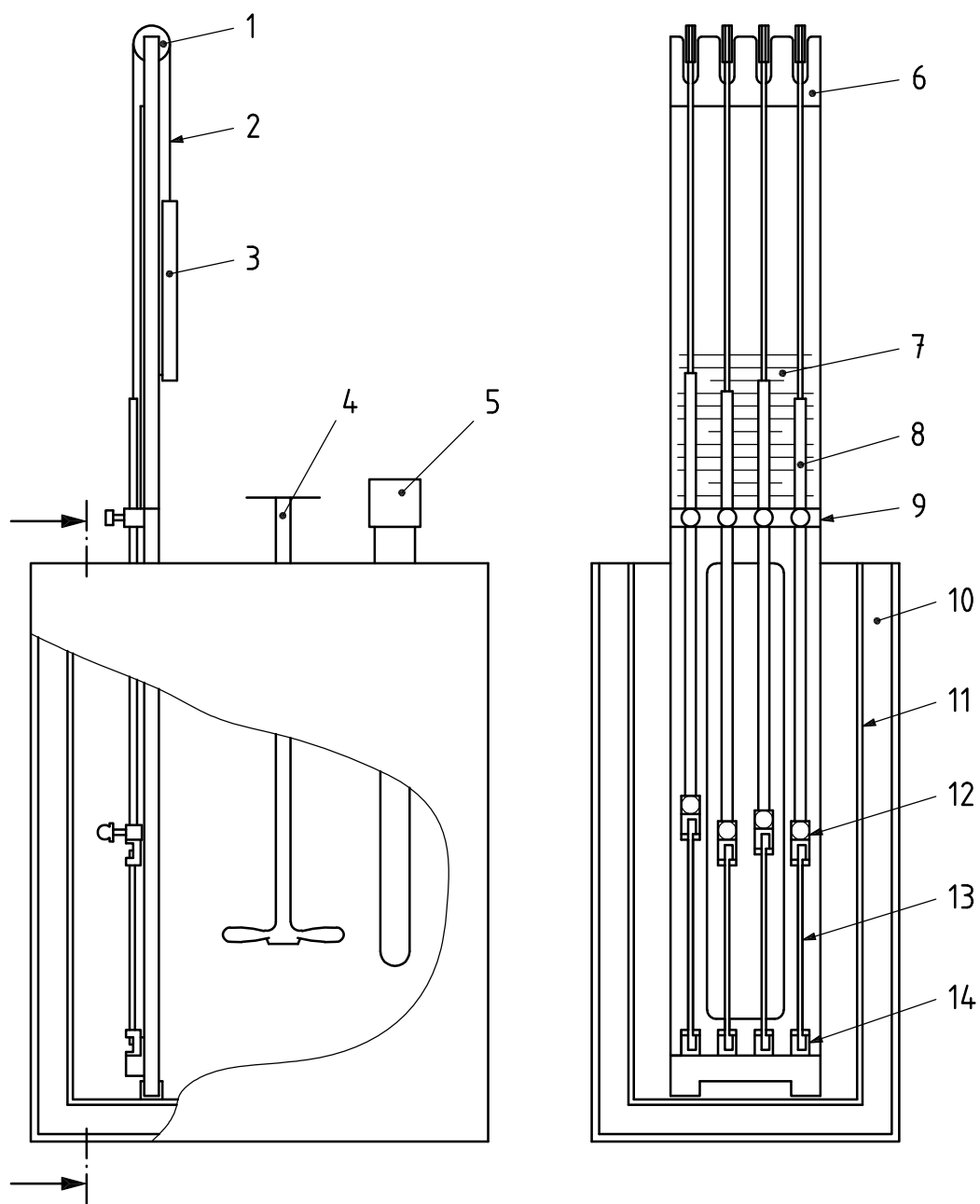

Key

- 1 pulley
- 2 cord
- 3 counterweight
- 4 stirrer
- 5 heating device (immersion heater) for coolant
- 6 rack
- 7 removable graduated scales
- 8 upper part of upper test piece holder
- 9 locking device for upper test piece holder
- 10 thermal insulation
- 11 container for coolant
- 12 upper test piece holder
- 13 test piece
- 14 lower test piece holder

Figure 1 — Retraction apparatus

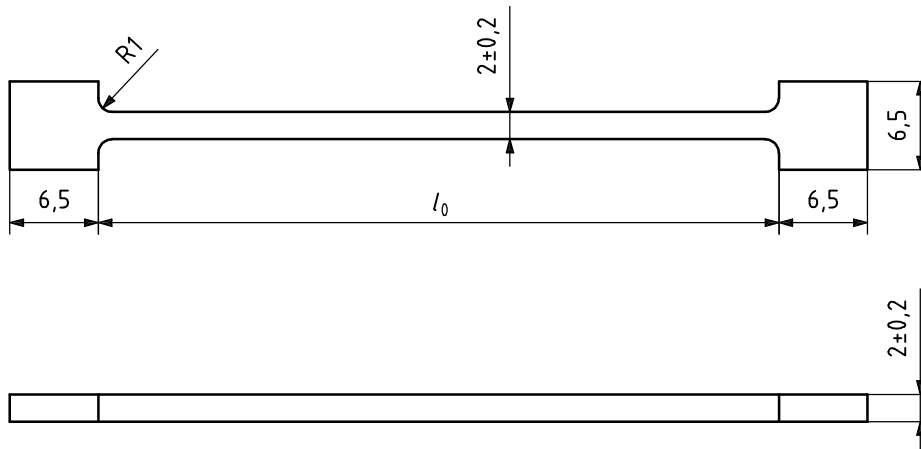

The reference length l_0 is preferably 100 mm \pm 0,2 mm for small elongations and 50 mm \pm 0,2 mm for large elongations (see 5.2.1)

Figure 2 — Test piece

5.4 Conditioning

5.4.1 Unless otherwise specified for technical reasons, the procedure in 5.4.2 to 5.4.5 shall be followed.

5.4.2 The time-interval between vulcanization and testing shall be in accordance with ISO 23529.

5.4.3 Samples and test pieces shall be protected from light as completely as possible during the interval between vulcanization and testing.

5.4.4 Test pieces shall be conditioned, immediately before testing, at one of the standard laboratory temperatures specified in ISO 23529.

5.4.5 If samples that are apt to crystallize are exposed to low storage temperatures before testing, crystallization may occur that largely affects the TR values measured. If values for the material in the uncrystallized condition are desired, the test pieces shall be decrystallized before testing by heating them in an oven at 70 °C for 30 min. They shall then be conditioned at standard laboratory temperature for at least 30 min but not more than 60 min.

6 Procedure

The bath shall contain enough coolant (4.2) to cover the test pieces with at least 25 mm of liquid during testing. Cool the coolant, whilst stirring, to below -70 °C as described in ISO 23529.

While the liquid is cooling, insert the test pieces in the rack (4.3) and, at the standard laboratory temperature, stretch the reference length to the chosen elongation and lock each test piece in position. Ensure that the test piece is only kept stretched at standard laboratory temperature for the minimum time.

The elongation shall be chosen in the light of the following criteria:

- a) provided technical reasons do not dictate otherwise and to reduce the effect of crystallization, an elongation of 50 % shall be used;

b) one of the following elongations shall be used to study the combined effect of crystallization and low temperature:

- 1) 250 %,
- 2) half the elongation at break if 250 % is unobtainable,
- 3) 350 %, if the elongation at break is greater than 600 %.

When the coolant has reached an equilibrium temperature between $-70\text{ }^{\circ}\text{C}$ and $-73\text{ }^{\circ}\text{C}$, place the rack with the test pieces in the bath. Allow to stand for $10\text{ min} \pm 2\text{ min}$ in the bath between $-70\text{ }^{\circ}\text{C}$ and $-73\text{ }^{\circ}\text{C}$. Release the locking device holding the upper holder and allow the test pieces to retract freely. At the same time, raise the temperature of the liquid at the rate of $1\text{ }^{\circ}\text{C}/\text{min}$, the tolerance being such that the temperature rise during any 10 min interval is within $10\text{ }^{\circ}\text{C} \pm 2\text{ }^{\circ}\text{C}$.

Should an elongated test piece retract to the original length at $-70\text{ }^{\circ}\text{C}$, cool to a lower temperature, using, if necessary, another coolant.

Take the first reading at $-70\text{ }^{\circ}\text{C}$ and continue to read the actual temperature and the retracted length or the percentage retraction every 2 min until retraction has reached 75 %.

NOTE 1 For the study of crystallization effects or the effect of long-term exposure, longer times of exposure under strain at one or more selected low temperatures may be used depending on the purpose of the test and the material under investigation.

NOTE 2 Different elongations do not necessarily give the same results.

7 Expression of results

The percentage retraction r may be read from the graduated scales or calculated from the equation:

$$r = \frac{l_s - l_r}{l_s - l_0} \times 100$$

where

- l_s is the stretched length in the locked position;
- l_r is the retracted length at the temperature concerned;
- l_0 is the reference length.

Plot r against the actual temperature on a graph.

From the graph, read the temperatures which correspond to retractions of 10 %, 30 %, 50 % and 70 %. These temperatures are designated TR10, TR30, TR50 and TR70.

Calculate the median value of three determinations of the temperature for TR10, TR30, TR50 and TR70.

8 Test report

The test report shall include the following information:

- a) sample details:
 - 1) a full description of the sample and its origin,
 - 2) compound details and cure details, where appropriate,
 - 3) the method of preparation of the test pieces from the sample, for example moulded or cut;

b) test method:

- 1) a reference to the test method used, i.e. the number of this International Standard,
- 2) the type of test piece used;

c) test details:

- 1) the standard laboratory temperature,
- 2) the time and temperature of conditioning prior to the test,
- 3) the elongation on freezing,
- 4) the coolant used,
- 5) details of any procedures not specified in this International Standard;

d) test results:

- 1) the number of test pieces used,
- 2) the individual and median values of TR10, TR30, TR50 and TR70,
- 3) the date of test.

