**Paints and varnishes — Determination
of viscosity using rotary viscometers —**

Part 1:

Cone-and-plate viscometer operated at a high
rate of shear

*Peintures et vernis — Détermination de la viscosité au moyen de
viscosimètres rotatifs —*

Partie 1: Viscosimètre à cône et plateau à gradient de vitesse élevé



Foreword

ISO (the International Organization for Standardization) is a worldwide federation of national standards bodies (ISO member bodies). The work of preparing International Standards is normally carried out through ISO technical committees. Each member body interested in a subject for which a technical committee has been established has the right to be represented on that committee. International organizations, governmental and non-governmental, in liaison with ISO, also take part in the work. ISO collaborates closely with the International Electrotechnical Commission (IEC) on all matters of electrotechnical standardization.

International Standards are drafted in accordance with the rules given in the ISO/IEC Directives, Part 3.

Draft International Standards adopted by the technical committees are circulated to the member bodies for voting. Publication as an International Standard requires approval by at least 75 % of the member bodies casting a vote.

International Standard ISO 2884-1 was prepared by Technical Committee ISO/TC 35, *Paints and varnishes*, Subcommittee SC 9, *General test methods for paints and varnishes*.

Together with the other parts (see below), this part of ISO 2884 cancels and replaces ISO 2884:1974, which has been technically revised. The main changes are:

- a) only a cone-and-plate viscometer is now specified;
- b) the shear rate is within a narrower range.

ISO 2884 consists of the following parts, under the general title *Paints and varnishes — Determination of viscosity using rotary viscometers*:

- *Part 1: Cone-and-plate viscometer operated at a high rate of shear*
- *Part 2: Disc or ball viscometer operated at a single specified speed*
- *Part 3: Disc and spindle viscometer operated at different speeds*
- *Part 4: Paddle viscometer operated at a single specified speed*

Annex A of this part of ISO 2884 is for information only.

© ISO 1999

All rights reserved. Unless otherwise specified, no part of this publication may be reproduced or utilized in any form or by any means, electronic or mechanical, including photocopying and microfilm, without permission in writing from the publisher.

International Organization for Standardization
Case postale 56 • CH-1211 Genève 20 • Switzerland
Internet iso@iso.ch

Printed in Switzerland

Paints and varnishes — Determination of viscosity using rotary viscometers —

Part 1:

Cone-and-plate viscometer operated at a high rate of shear

1 Scope

This part of ISO 2884 is one of a series dealing with the sampling and testing of paints, varnishes and related products.

It supplements ISO 2431:1993, *Paints and varnishes — Determination of flow time by use of flow cups*.

It specifies the general procedure to be followed in determining the dynamic viscosity of paints, varnishes and related products at a rate of shear between $9\,000\text{ s}^{-1}$ and $12\,000\text{ s}^{-1}$.

The value obtained gives information about the resistance offered by the material to brushing, spraying and roller coating during application.

The method specified in this part of ISO 2884 is suitable for all paints and varnishes whether they are Newtonian in behaviour or not. Materials containing dispersions of large particles will produce spurious results.

2 Normative references

The following normative documents contain provisions which, through reference in this text, constitute provisions of this part of ISO 2884. For dated references, subsequent amendments to, or revisions of, any of these publications, do not apply. However, parties to agreements based on this part of ISO 2884 are encouraged to investigate the possibility of applying the most recent editions of the normative documents indicated below. Members of ISO and IEC maintain registers of currently valid International Standards.

ISO 1513:1992, *Paints and varnishes — Examination and preparation of samples for testing*.

ISO 15528:—¹⁾, *Paints and varnishes — Sampling*.

3 Apparatus

3.1 Viscometer, with cone-and-plate geometry, working at a rate of shear between $9\,000\text{ s}^{-1}$ and $12\,000\text{ s}^{-1}$. The actual apparatus used shall be agreed between the interested parties, and the details given in the test report. A simple apparatus for routine use is described in annex A.

1) To be published. (Revision of ISO 842:1984 and ISO 1512:1991)

4 Sampling

Take a representative sample of the product to be tested, as described in ISO 15528. Then examine the sample and prepare it for testing, as described in ISO 1513. If the sample has a tendency to sediment or separate on standing, stir it until it is homogeneous, taking care not to incorporate air bubbles. The sample shall be free of any foreign matter or lumps. The volume of the sample shall be sufficient to fill the gap between the cone and plate.

NOTE Samples containing large particles will produce anomalous results and can cause damage to the instrument. For cone-and-plate viscometers with truncated cones, the larger particles in the sample should be less than a tenth the size of the gap between the cone and the plate.

5 Checking the apparatus

Check the apparatus on a regular basis in accordance with the manufacturer's recommendations and from experience gained in the use of the instrument, comparing the results against those from previous checks and hence establishing the frequency of checking required. Check by carrying out the determination as outlined in clause 7, using standard refined mineral oils having Newtonian characteristics and known viscosities (use three mineral oils with viscosities certified by an approved laboratory and lying between 0,05 Pa·s and 0,5 Pa·s). Check the cones regularly for wear and replace them if they show signs of scoring or, for cones that are not truncated, signs of flattening.

If the readings obtained differ from the known viscosities of the standard oils by more than 5 %, the apparatus shall be checked by a competent instrument engineer or returned to the manufacturer for adjustment.

NOTE Silicone oils should preferably be avoided because of their tendency to contaminate instruments and because of the possibility of shear-thinning behaviour at high shear rates.

6 Checking the temperature control

To check that the temperature does not change during the determination, carry out the determination as outlined in clause 7 with the standard oil of the highest viscosity as indicated by the scale reading.

Allow the viscometer to run with this oil for 5 min, after which the reading shall not have decreased by more than 10 %. If the decrease is more than 10 %, the apparatus is unsuitable, as set up, for the determination of viscosities at high rates of shear in accordance with this part of ISO 2884.

7 Procedure

7.1 Carry out the following sequence of operations in duplicate immediately after the preparation of the sample in accordance with clause 4, first allowing the apparatus to warm up in accordance with the manufacturer's instructions.

When the viscosities of products are being compared, the rate of shear shall be the same. The determination shall be carried out at $(23 \pm 0,2)$ °C unless otherwise agreed.

7.2 Adjust the temperature of the stationary part of the viscometer to $(23 \pm 0,2)$ °C or to an alternatively agreed temperature. Transfer a suitable amount of the product to be tested to the appropriate part of the viscometer, taking care to avoid the inclusion of air bubbles, and adjust the other part to the correct position. Wait for the prescribed time, dependent on the apparatus used, to allow the sample to attain the agreed temperature.

7.3 Start the rotor and record the reading on the scale when the reading becomes steady. If the reading does not become steady after 15 s, the reading at 15 s shall be recorded and the lack of a constant reading shall be mentioned in the test report.

7.4 If the reading does not directly indicate the viscosity, multiply the reading by the appropriate conversion factor or use an appropriate calibration curve to obtain the viscosity.

8 Cleaning the apparatus

Clean the stator and rotor carefully after each determination, employing a suitable solvent. The procedure to be used will depend on the apparatus, but care shall be taken to remove all of the test material and cleaning solvent. Cleaning utensils which may damage the apparatus shall not be used. Metal cleaning tools shall never be used.

9 Precision

The results of two determinations with the same apparatus taken shortly after one other in the same laboratory by the same operator shall not differ by more than 5 % of their mean.

10 Test report

The test report shall contain at least the following information:

- a) all details necessary to identify the product tested;
- b) a reference to this part of ISO 2884 (ISO 2884-1);
- c) the type of apparatus used, stating the angle and diameter of the cone;
- d) the shear rate used;
- e) the temperature used;
- f) the test results in Pa·s or mPa·s;
- g) any deviation from the test procedure described, and whether agreed or not;
- h) the date of the test.

Annex A (informative)

Cone-and-plate viscometers

A.1 Description of a simple cone-and-plate viscometer for routine use

Cone-and-plate viscometers comprise a suitable electric motor that drives, at a constant rotational speed, a cone whose vertex touches a rigid temperature-controlled plate. The torque is measured either electronically or mechanically. Cone-and-plate viscometers are widely used for routine high-shear viscosity measurements. The geometry is shown in Figure A.1.

The instrument is designed so that the cone and motor assembly can be easily raised, first while the test liquid is being placed on the plate and later to permit thorough cleaning after each measurement.

In use, the liquid just fills the narrow gap between the plate and the cone.

The main characteristics are described in Table A.1.

Dimensions in millimetres

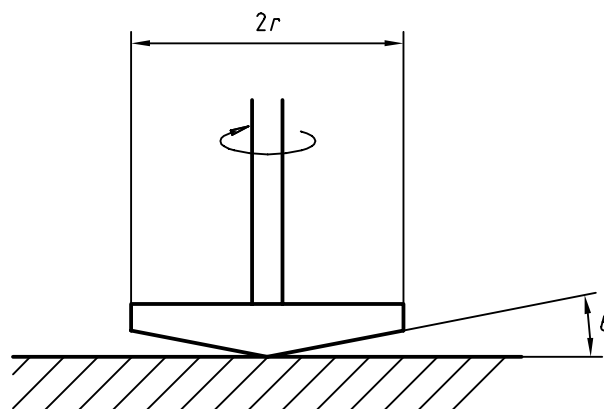

Figure A.1 — Cone and plate geometry

Table A.1 — Viscometer characteristics

Characteristic	
Viscosity range	0 to 1 Pa·s (0 to 10 P)
Rotational speed	(750 ± 10) rpm
Cone diameter	Dependent on speed, angle and torque selected (typically 24 mm)
Cone angle	0,5° ± 2' produces a shear rate of 9 000 s ⁻¹
Shear rate (calculated)	9 000 s ⁻¹

A.2 Viscometric formulae

The equations governing the shear stress and shear rate for a cone-and-plate instrument are given below:

$$\text{Shear rate (s}^{-1}\text{)} = \frac{\omega}{\tan \theta}$$

$$\text{Shear stress (Pa)} = \frac{3T}{2\pi r^3}$$

$$\text{Viscosity (Pa}\cdot\text{s)} = \frac{3T \tan \theta}{2\pi \omega r^3}$$

where

- T is the torque, in newton metres;
- ω is the angular velocity, in radians per second;
- r is the radius of the cone, in metres;
- θ is the cone angle, in radians.

Bibliography

- [1] FINK-JENSEN, P.H., and RAASCHOU NIELSEN, H.K.: "Assessment of application properties of brushing paints", (report from the Organic Coatings Section, International Union of Pure and Applied Chemistry), *J Paint Techn.*, **43** (1971), No. 561, pp. 60-67.
- [2] MONK, C.J.H.: "Routine measurement of the viscosity of paint samples", *JOCCA*, **49** (1966), pp. 543-550.

ICS 87.040

Price based on 6 pages
