

INTERNATIONAL STANDARD

ISO 2875

Third edition
2000-03-01

Packaging — Complete, filled transport packages and unit loads — Water-spray test

*Emballages — Emballages d'expédition complets et pleins et charges
unitaires — Essai de résistance aux projections d'eau*



Reference number
ISO 2875:2000(E)

© ISO 2000

PDF disclaimer

This PDF file may contain embedded typefaces. In accordance with Adobe's licensing policy, this file may be printed or viewed but shall not be edited unless the typefaces which are embedded are licensed to and installed on the computer performing the editing. In downloading this file, parties accept therein the responsibility of not infringing Adobe's licensing policy. The ISO Central Secretariat accepts no liability in this area.

Adobe is a trademark of Adobe Systems Incorporated.

Details of the software products used to create this PDF file can be found in the General Info relative to the file; the PDF-creation parameters were optimized for printing. Every care has been taken to ensure that the file is suitable for use by ISO member bodies. In the unlikely event that a problem relating to it is found, please inform the Central Secretariat at the address given below.

© ISO 2000

All rights reserved. Unless otherwise specified, no part of this publication may be reproduced or utilized in any form or by any means, electronic or mechanical, including photocopying and microfilm, without permission in writing from either ISO at the address below or ISO's member body in the country of the requester.

ISO copyright office
Case postale 56 • CH-1211 Geneva 20
Tel. + 41 22 749 01 11
Fax + 41 22 734 10 79
E-mail copyright@iso.ch
Web www.iso.ch

Printed in Switzerland

Foreword

ISO (the International Organization for Standardization) is a worldwide federation of national standards bodies (ISO member bodies). The work of preparing International Standards is normally carried out through ISO technical committees. Each member body interested in a subject for which a technical committee has been established has the right to be represented on that committee. International organizations, governmental and non-governmental, in liaison with ISO, also take part in the work. ISO collaborates closely with the International Electrotechnical Commission (IEC) on all matters of electrotechnical standardization.

International Standards are drafted in accordance with the rules given in the ISO/IEC Directives, Part 3.

Draft International Standards adopted by the technical committees are circulated to the member bodies for voting. Publication as an International Standard requires approval by at least 75 % of the member bodies casting a vote.

Attention is drawn to the possibility that some of the elements of this International Standard may be the subject of patent rights. ISO shall not be held responsible for identifying any or all such patent rights.

International Standard ISO 2875 was prepared by Technical Committee ISO/TC 122, *Packaging*, Subcommittee SC 3, *Performance requirements and tests for means of packaging, packages and unit loads (as required by ISO/TC 122)*.

This third edition cancels and replaces the second edition (ISO 2875:1985) which has been technically revised.

Introduction

It is the responsibility of the user of this International Standard to establish appropriate health and safety practice in accordance with relevant legislation.

Packaging — Complete, filled transport packages and unit loads — Water-spray test

1 Scope

This International Standard specifies a method for testing the resistance of a complete, filled transport package or a unit load to water spray or the protection it gives to its contents from water spray. It may also be used to precondition a complete, filled transport package or a unit load prior to another test to investigate reduction in strength caused by exposure to water.

The test is performed on the test specimen as prepared for transport and may form part of a test sequence.

2 Normative references

The following normative documents contain provisions which, through reference in this text, constitute provisions of this International Standard. For dated references, subsequent amendments to, or revisions of, any of these publications do not apply. However, parties to agreements based on this International Standard are encouraged to investigate the possibility of applying the most recent editions of the normative documents indicated below. For undated references, the latest edition of the normative document referred to applies. Members of ISO and IEC maintain registers of currently valid International Standards.

ISO 2206, *Packaging — Complete, filled transport packages — Identification of parts when testing.*

ISO 2233, *Packaging — Complete, filled transport packages and unit loads — Conditioning for testing.*

3 Term and definition

For the purposes of this International Standard, the following term and definition applies.

3.1

test specimen

a complete, filled transport package or unit load

4 Principle

The test specimen is placed in a test area and its top surface sprayed with water maintained at a constant temperature at a specified rate for a specified period. Each area of the surface is sprayed either continuously (method A) or intermittently (method B).

5 Apparatus and conditions

5.1 **Test area conditions**, shall be as follows:

- **insulated and heated**, when necessary, to allow temperature to be controlled, fitted with a floor grating and an outlet of sufficient capacity to drain off the water as it is sprayed so that the test specimen does not stand in a pool of water. The grating shall not, through lack of rigidity or having too wide a mesh, cause deformation of the test specimen;
- **height**, sufficient to give a distance of at least 2 m between the spray nozzles (5.2) and the nearest point on the test specimen, so that the drops fall vertically. The dimensions of the floor shall be at least 50 % greater than those of the base of the test specimen.

5.2 **Sprays**, adjustable in height and fitted with nozzles of a design allowing water to fall vertically at a rate of (100 ± 20) l/m²·h onto a horizontal area 2 m below the nozzles, sufficiently uniformly to meet the requirements of the calibration test in 7.1, arranged in accordance with method A or method B as follows:

- **method A** (continuous spraying): an array of sprays, fixed in position above the test specimen, after adjusting for height;
- **method B** (intermittent spraying): a row or rows of sprays across the width of the test specimen, capable of traversing a distance greater than the length of the test specimen at a constant velocity to meet the requirements of 7.1, with the interval between successive sprayings being less than 30 s.

5.3 **Water supply system**, supplying water at the required temperature (within a range of 5 °C and 30 °C) and at the rate and pressure required by the spray nozzles (5.2).

NOTE Figure 1 shows an example of apparatus configured appropriately for the operation of these tests.

6 Test specimen preparation

Fill the test specimen with its intended contents and ensure that the test specimen is closed normally, as if ready for distribution.

NOTE 1 Simulated or substitute contents may be used on condition that the dimensions and physical properties of such contents are as close as possible to those of the intended contents. The closure should still be as for distribution.

NOTE 2 Conditioning, where appropriate, should be carried out in accordance with ISO 2233.

Dimensions in millimetres

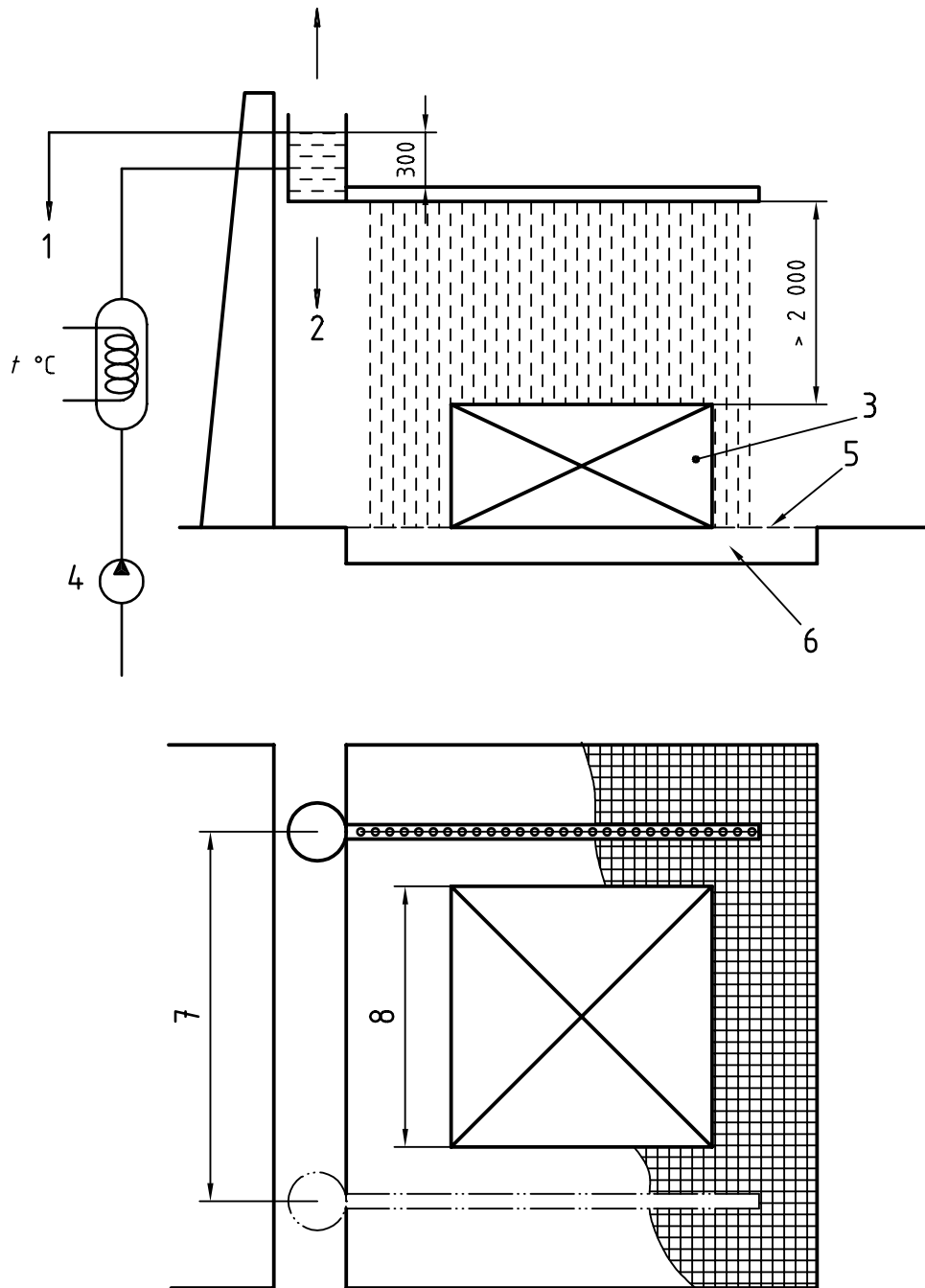

Key

- | | |
|-------------------------------|-----------------------------|
| 1 Overflow | 5 Grating |
| 2 Height adjustment | 6 Drain |
| 3 Test specimen | 7 Travel of the upper spray |
| 4 Circulating pump or network | 8 Test specimen dimensions |

Figure 1 — Apparatus for the water spray test

7 Procedure

7.1 Calibration

7.1.1 The sprays (5.2) shall be mounted 2 m above the surface of the floor, with nozzles directed vertically downwards.

7.1.2 Sufficient identical open-top containers, of a design having an aperture area between 0,25 m² and 0,5 m² and height between 0,25 m and 0,5 m, shall be placed uniformly on the surface of the floor to cover at least 25 % of its area.

7.1.3 The sprays shall then be turned on and the times taken for the first and last containers to fill to overflowing shall be measured.

7.1.4 The time taken for the first to overflow shall not exceed that represented by a rate of 120 l/m²·h; that of the least shall not be less than that represented by 80 l/m²·h.

7.2 Test

7.2.1 Adjust the height of the sprays (5.2) to give a vertical distance of at least 2 m between the spray nozzles and the nearest point on the test specimen. Operate the sprays until the entire system has reached equilibrium. Unless otherwise specified, the temperature of the spray water and test area (5.1) shall be between 5 °C and 30 °C.

7.2.2 Place the test specimen centrally in the test area, in the predetermined position and at the predetermined temperature so that the water falls vertically on the test specimen. Operate the sprays continuously, as calibrated, for the specified period.

7.2.3 Examine the test specimen and its contents for any reduction in protective properties and/or infiltration of water.

8 Test report

The test report shall include:

- a) a reference to this International Standard;
- b) the name and address of testing laboratory and the name and address of the customer;
- c) the unique identification of the report;
- d) the date of receipt of the test specimens and the date(s) of performance of the test;
- e) the name, title and signature of persons accepting test responsibility for the test report;
- f) a statement to the effect that the test results relate only to the specimens tested;
- g) a statement that the report shall not be reproduced except in full without the written approval of the testing laboratory;
- h) the number of replicate test specimens tested;
- i) a full description including dimensions, structural and material specifications of the test specimen and its fittings, cushioning, blocking, closure or reinforcing arrangements, gross mass of the test specimen and mass of the contents in kilograms;
- j) a description of the contents and if simulated or substituted contents were used, full details shall be given;

- k) the relative humidity, the temperature and time of conditioning, and whether these values comply with the requirements of ISO 2233;
- l) the method used (A or B);
- m) the attitudes in which the test specimen was tested, using the method of identification given in ISO 2206;
- n) the temperature of the test area and of the water at time of test;
- o) the duration of the test;
- p) any deviation from the test method described in this International Standard;
- q) a record of the result, including any observations which assist in the correct interpretation of the results.

ICS 55.180.40

Price based on 5 pages

© ISO 2000 – All rights reserved