

INTERNATIONAL
STANDARD

ISO
2861

First edition
2013-05-01

Vacuum technology — Dimensions of clamped-type quick-release couplings

Technique du vide — Dimensions des raccords rapides



Reference number
ISO 2861:2013(E)

© ISO 2013



COPYRIGHT PROTECTED DOCUMENT

© ISO 2013

All rights reserved. Unless otherwise specified, no part of this publication may be reproduced or utilized otherwise in any form or by any means, electronic or mechanical, including photocopying, or posting on the internet or an intranet, without prior written permission. Permission can be requested from either ISO at the address below or ISO's member body in the country of the requester.

ISO copyright office
Case postale 56 • CH-1211 Geneva 20
Tel. + 41 22 749 01 11
Fax + 41 22 749 09 47
E-mail copyright@iso.org
Web www.iso.org

Published in Switzerland

Foreword

ISO (the International Organization for Standardization) is a worldwide federation of national standards bodies (ISO member bodies). The work of preparing International Standards is normally carried out through ISO technical committees. Each member body interested in a subject for which a technical committee has been established has the right to be represented on that committee. International organizations, governmental and non-governmental, in liaison with ISO, also take part in the work. ISO collaborates closely with the International Electrotechnical Commission (IEC) on all matters of electrotechnical standardization.

The procedures used to develop this document and those intended for its further maintenance are described in the ISO/IEC Directives, Part 1. In particular the different approval criteria needed for the different types of ISO documents should be noted. This document was drafted in accordance with the editorial rules of the ISO/IEC Directives, Part 2. www.iso.org/directives

Attention is drawn to the possibility that some of the elements of this document may be the subject of patent rights. ISO shall not be held responsible for identifying any or all such patent rights. Details of any patent rights identified during the development of the document will be in the Introduction and/or on the ISO list of patent declarations received. www.iso.org/patents

Any trade name used in this document is information given for the convenience of users and does not constitute an endorsement.

The committee responsible for this document is ISO/TC 112, *Vacuum technology*.

This first edition of ISO 2861 cancels and replaces 2861-1:1974, of which it constitutes a technical revision. The most important change is the addition of the dimension for 50 mm nominal bore quick-release couplings and their constituent parts to the dimensions of the four nominal bore sizes, 10 mm, 16 mm, 25 mm and 40 mm, already specified in the replaced standard (ISO 2861-2:1980, *Vacuum technology — Quick release couplings — Dimensions — Part 2: Screwed type*, was withdrawn in 2010).

.....

Vacuum technology — Dimensions of clamped-type quick-release couplings

1 Scope

This International Standard specifies the dimensions of the clamped-type quick-release couplings used in vacuum technology, as well as those of the O-rings and their carriers associated with these couplings, used to ensure vacuum tightness.

NOTE The dimensions retained for the coupling diameter ensure the compatibility of the quick-release coupling with the corresponding vacuum flanges specified in ISO 1609.^[1]

2 Terms and definitions

For the purposes of this document, the following terms and definitions apply.

3.1

clamped-type quick-release coupling

connection which may be joined or separated without the use of tools

[SOURCE: ISO 14617-3:2002, 3.15, modified — “clamped-type” has been added to the term; Notes 1 to 3 are additional to the original definition.]

Note 1 to entry: Ensures vacuum tightness associated with the O-rings and their carriers.

Note 2 to entry: The types and dimensions of clamps to tight couplings are not specified in this International Standard.

Note 3 to entry: See [Figure 1](#).

.....

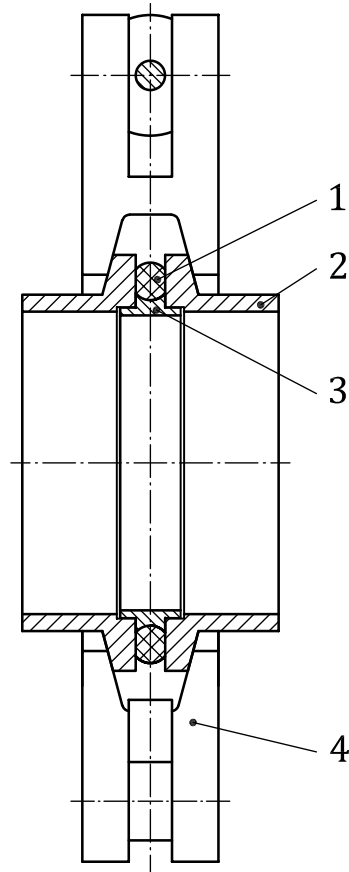

Key

- 1 O-ring
- 2 coupling
- 3 O-ring carrier
- 4 clamp

Figure 1 — Quick-release coupling with typical clamp

3 Symbols

Symbol	Description	Unit
D	Inside diameter of O-ring	mm
d_1	Outside diameter of connecting pipe	mm
d_2	Diameter of O-ring carrier retainer	mm
d_3	Outside diameter of coupling	mm
d_4	Inside diameter of O-ring carrier	mm
d_5	Outside diameter connecting pipe of O-ring carrier	mm
d_6	Outside diameter to hold O-ring in O-ring carrier	mm
R	Radius of O-ring retainer in O-ring carrier	mm

4 Requirements

4.1 Coupling

Dimensions of couplings shall be in accordance with [Table 1](#). See [Figure 2](#).

The selection of the material shall be compatible with the requirements for the couplings. Considerations may include service temperature, sealing capacity, corrosion-resistance, magnetic permeability, the type of seal gasket (O-ring) used and dimensions.

NOTE Austenitic stainless steel is commonly used, but it is not the intent of this Standard to specify or limit the choice of coupling material to austenitic stainless steel.

Dimensions in millimetres

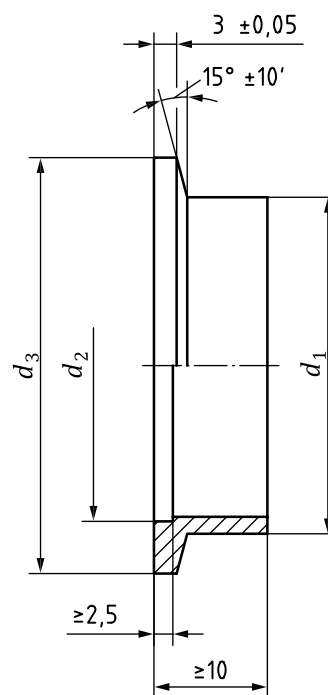

Figure 2 — Coupling

Table 1 — Dimensions of couplings

Dimensions in millimetres

Nominal bore	d_1 max.	d_2 $+0,2$ 0	d_3 h11
10	14	12,2	30
16	20	17,2	30
25	28	26,2	40
40	44,5	41,2	55
50	61	52,2	75

4.2 O-ring

Dimensions of O-rings shall be in accordance with [Table 2](#). See [Figure 3](#).

The O-ring shall be of elastomer. The selection of the elastomer shall be compatible with the requirements for the couplings. Considerations may include service temperature, sealing capacity, corrosion-resistance and dimensions.

NOTE Fluorocarbon rubber is commonly used, but it is not the intent of this International Standard to specify or limit the choice of O-ring material to rubber.

Dimensions in millimetres

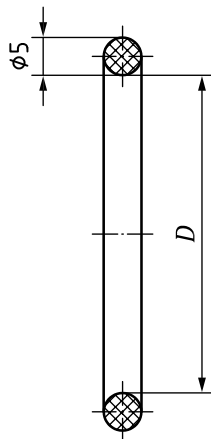

Figure 3 — O-ring

Table 2 — Dimensions of O-ring

Dimensions in millimetres

Nominal bore	<i>D</i>
10	15
16	18
25	28
40	42 ^a
50	55 ^b

^a Alternatively, an O-ring of section 5,33 mm and diameter *D* of 40,65 mm may be used.

^b Alternatively, an O-ring of section 5,33 mm and diameter *D* of 53,3 mm may be used.

4.3 O-ring carrier

Dimensions of O-ring carriers shall be in accordance with [Table 3](#). See [Figure 4](#).

The selection of the O-ring carrier shall be compatible with the requirements for the couplings. Considerations may include service temperature, sealing capacity, corrosion-resistance, magnetic permeability, the type of seal gasket (O-ring) used and dimensions.

NOTE Austenitic stainless steel is commonly used, but it is not the intent of this International Standard to specify or limit the choice of O-ring carrier material to austenitic stainless steel.

Dimensions in millimetres

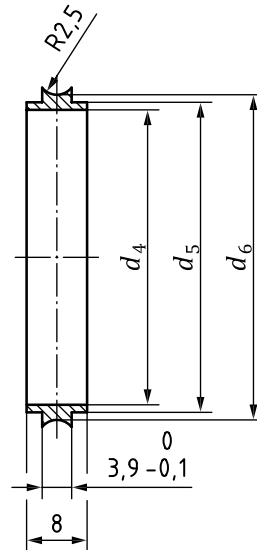

Figure 4 — O-ring carrier

Table 3 — Dimensions of O-ring carrier

Dimensions in millimetres

Nominal bore	d_1 max.	d_5 $\begin{matrix} 0 \\ -0,1 \end{matrix}$	d_6 h11
10	10	12	15,3
16	16	17	18,5
25	25	26	28,5
40	40	41	43
50	50	52	55,5

4.4 Clamp

The selection of the clamp shall be compatible with the requirements for the couplings. Considerations may include service temperature, sealing capacity, corrosion-resistance, magnetic permeability, the type of seal gasket (O-ring) used and dimensions.

NOTE Aluminium and austenitic stainless steel are commonly used, but it is not the intent of this International Standard to specify or limit the choice of clamp material to aluminium or austenitic stainless steel.

Bibliography

- [1] ISO 1609:1986, *Vacuum technology — Flange dimensions*

