

UB/TIB Hannover

R N 86

INTERNATIONAL STANDARD

ISO 2818

Third edition
1994-08-15

Plastics — Preparation of test specimens by machining

Plastiques — Préparation des éprouvettes par usinage



Reference number
ISO 2818:1994(E)

Foreword

ISO (the International Organization for Standardization) is a worldwide federation of national standards bodies (ISO member bodies). The work of preparing International Standards is normally carried out through ISO technical committees. Each member body interested in a subject for which a technical committee has been established has the right to be represented on that committee. International organizations, governmental and non-governmental, in liaison with ISO, also take part in the work. ISO collaborates closely with the International Electrotechnical Commission (IEC) on all matters of electrotechnical standardization.

Draft International Standards adopted by the technical committees are circulated to the member bodies for voting. Publication as an International Standard requires approval by at least 75 % of the member bodies casting a vote.

International Standard ISO 2818 was prepared by Technical Committee ISO/TC 61, *Plastics*, Subcommittee SC 2, *Mechanical properties*.

This third edition cancels and replaces the second edition (ISO 2818:1980), which has been revised with respect to the following points:

- normative references for the geometry of cutting tools and abrasive tools and products;
- introduction of notching;
- extension of the table for recommended machining conditions.

Annex A of this International Standard is for information only.

© ISO 1994

All rights reserved. Unless otherwise specified, no part of this publication may be reproduced or utilized in any form or by any means, electronic or mechanical, including photocopying and microfilm, without permission in writing from the publisher.

International Organization for Standardization
Case Postale 56 • CH-1211 Genève 20 • Switzerland

Printed in Switzerland

Introduction

The preparation of test specimens by machining influences the finished surfaces and, in some cases, even the internal structure of the specimens. Since test results are strongly dependent on both of these parameters, exact definitions of tools and machining conditions are required for reproducible test results with machined specimens.

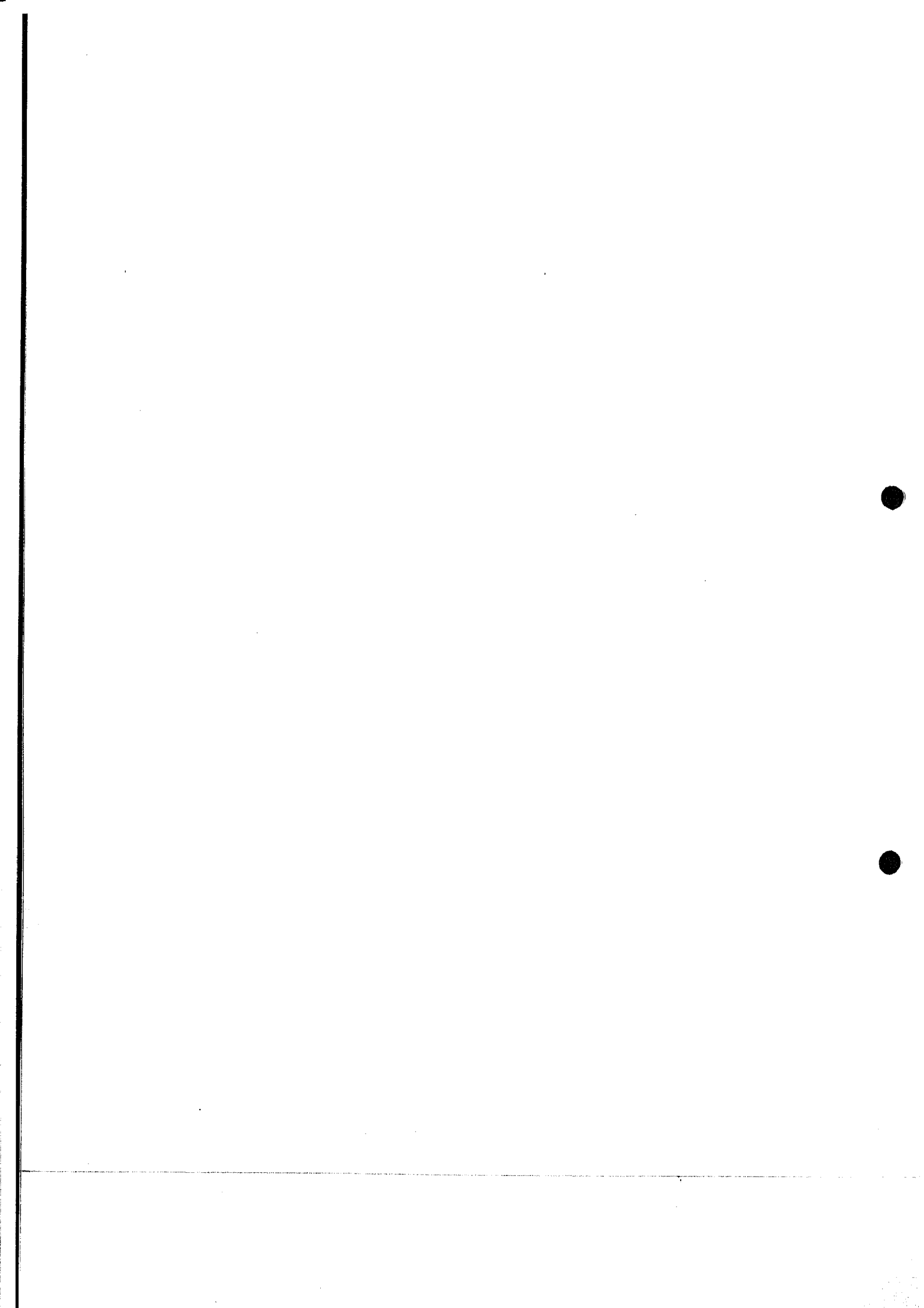

Plastics — Preparation of test specimens by machining

1 Scope

This International Standard establishes the general principles and procedures to be followed when machining and notching test specimens from compression-moulded and injection-moulded plastics, extruded sheets, plates and partially finished or wholly finished products.

In order to establish a basis for reproducible machining and notching conditions, the following general standardized conditions should be applied. It is assumed, however, that the exact procedures to be used will be selected or specified by the relevant material specification or by the standards on the particular test methods. If sufficiently detailed procedures are not thus specified, it is essential that the interested parties agree on the conditions to be used.

2 Normative references

The following standards contain provisions which, through reference in this text, constitute provisions of this International Standard. At the time of publication, the editions indicated were valid. All standards are subject to revision, and parties to agreements based on this International Standard are encouraged to investigate the possibility of applying the most recent editions of the standards indicated below. Members of IEC and ISO maintain registers of currently valid International Standards.

ISO 3002-1:1982, *Basic quantities in cutting and grinding — Part 1: Geometry of the active part of cutting tools — General terms, reference systems, tool and working angles, chip breakers.*

ISO 3017:1981, *Abrasive discs — Designation, dimensions and tolerances — Selection of disc outside diameter/centre hole diameter combinations.*

ISO 3855:1977, *Milling cutters — Nomenclature.*

ISO 6104:1979, *Abrasive products — Diamond or cubic boron nitride grinding wheels and saws — General survey, designation and multilingual nomenclature.*

ISO 6106:1979, *Abrasive products — Grain sizes of diamond or cubic boron nitride.*

ISO 6168:1980, *Abrasive products — Diamond or cubic boron nitride grinding wheels — Dimensions.*

3 Definitions

For the purposes of this International Standard, the following definitions apply:

3.1 Milling

In this machining operation, the tool has a circular primary motion and the workpiece a suitable feed motion. The axis of rotation of the primary motion retains its position with respect to the tool, independently of the feed motion (see ISO 3855). Complete dumb-bell and rectangular test specimens, as well as notches in finished specimens, may be prepared by milling.

3.1.1 Geometry (see 3002-1 and figure 1)

Only a few details of the exact geometrical conditions of the milling tool and its position with respect to the workpiece given in ISO 3002-1 are relevant to this standard, as follows:

3.1.1.1 tool-cutting-edge angle, α_r : The angle between the tool-cutting-edge plane P_s and the assumed working plane P_f , measured in the tool back plane P_r .

3.1.1.2 tool back clearance, α_p : The angle between the flank A_x of the cutter and the tool-cutting-edge plane P_s , measured in the tool back plane P_p .

3.1.1.3 tool side clearance, α_f : The angle between the flank A_x of the cutter and the tool-cutting-edge plane P_s , measured in the assumed working plane P_f .

3.1.1.4 tool radius, R : The distance between the axis of the circular primary motion of the tool and its cutting edge.

3.1.1.5 number of cutting teeth, z : The number of cutting edges on the outer periphery of the rotating milling tool.

3.1.2 Tool and workpiece motions (see ISO 3002-1 and figure 2)

3.1.2.1 rotational speed of tool, n : The speed, in revolutions per minute, of the circular primary motion of the tool.

3.1.2.2 cutting speed, v_c : The instantaneous velocity, in metres per minute, of the primary motion of a selected point on the cutting edge relative to the workpiece. The relationship between v_c and n is given by the equation $v_c = n \cdot 2\pi R$.

3.1.2.3 feed speed, v_f : The instantaneous velocity, in metres per minute, of the feed motion of a selected point on the cutting edge relative to the workpiece.

3.1.2.4 feed path, λ : The distance, in millimetres, at any given point on the surface of the workpiece covered during the time between two successive cutting operations. The feed path is given by the equation $\lambda = v_f/z \cdot n$.

3.1.2.5 cutting depth, a : The (mean) distance, in millimetres, between the surfaces of the workpiece before and after one complete milling run.

3.2 Cutting of rectangular test specimens

In this machining operation, rectangular test specimens are cut by means of a circular or band saw, made from hardened steel or coated with diamond or cubic boron nitride powder, or cut with the aid of an abrasive disc of which the cutting edge may be coated with diamond or boron nitride powder. For further details on abrasive discs and abrasive products, see ISO 3017 and ISO 6104.

3.2.1 Geometry

3.2.1.1 tool radius, R : The distance, in millimetres, between the rotary axis of a circular saw or an abrasive disc and the cutting edges of the tool.

3.2.1.2 number of cutting teeth, z : The number of cutting teeth on the periphery of a circular saw.

3.2.2 Tool and workpiece motions

3.2.2.1 rotational speed of tool, n : The speed of rotation, in revolutions per minute, of a circular saw or an abrasive disc.

3.2.2.2 cutting speed, v_c : The instantaneous velocity, in metres per minute, of the cutting tip of a saw tooth, or of a selected point on the cutting edge of an abrasive disc, relative to the workpiece. For a circular saw or an abrasive disc, the relationship between v_c and n is given by the equation $v_c = n \cdot 2\pi R$.

3.2.2.3 feed speed, v_f : The instantaneous velocity, in metres per minute, of the tool feed parallel to the saw or disc plane and perpendicular to the cutting direction relative to the workpiece.

3.3 Cutting of disc-shaped test specimens (see figure 4)

In this machining operation, disc-shaped test specimens are cut from sheet material with the aid of a circular cutter with a saw-toothed edge of hardened steel or which may be coated with diamond or cubic boron nitride powder. The test specimens may also be cut by means of a milling cutter with one or more teeth, as described in 3.1, which moves in a circular orbit. Furthermore, the test specimens may also be cut from a roughly preshaped pack of individual sheets with the aid of a turning lathe.

3.3.1 Geometry

3.3.1.1 tool radius, R : The distance, in millimetres, between the rotary axis of the circular cutter and the inner limit of the cutting edge. The tool radius is equal to the radius of the finished test specimen.

3.3.1.2 number of cutting teeth, z : The number of teeth on the sawtooth cutting edge of a circular cutter. If a lathe is used for cutting circular test specimens, the geometrical definitions of the cutting tool are the same as those given in 3.1.

3.3.2 Tool and workpiece motions

3.3.2.1 rotational speed of tool, n : The speed of rotation, in revolutions per minute, of a circular cutter.

3.3.2.2 cutting speed, v_c : The instantaneous velocity, in metres per minute, of a selected point on the cutting edge relative to the workpiece. The relation-

ship between v_c and n is given by the equation $v_c = n \cdot 2\pi R$.

3.3.2.3 feed speed, v_f : The instantaneous velocity, in metres per minute, of the tool feed parallel to the rotary axis of the circular cutter and perpendicular to the cutting direction relative to the workpiece.

3.4 Planing of rectangular bars and planing or broaching of notches in finished test specimens

In this machining operation, sawed or sliced rectangular bars are finished by planing. Also, notches in finished specimens can be cut by planing or broaching.

3.4.1 Geometry

3.4.1.1 tool-cutting-edge angle, α_r : As defined in 3.1.1.1.

3.4.1.2 tool back clearance, α_p : As defined in 3.1.1.2.

3.4.1.3 tool side clearance, α_f : As defined in 3.1.1.3.

3.4.2 Tool and workpiece motions

3.4.2.1 cutting speed, v_c : The instantaneous velocity, in metres per minute, of the primary motion of a selected point on the cutting edge relative to the workpiece.

3.4.2.2 cutting depth, a : The (mean) distance, in millimetres, between the surfaces of the workpiece before and after one planing run.

3.5 Stamping of arbitrarily shaped test specimens fabricated from thin sheets

In this operation, arbitrarily shaped test specimens are stamped under high pressure from thin sheets by means of a tool with a sharp edge made from hardened steel and located in a plane parallel to the plane of the sheet.

3.5.1 Geometry

3.5.1.1 shape of the stamping tool: The geometric shape of the stamping edge in a plane parallel to the sheet plane. The shape of the stamping tool depends on the shape of the test specimen to be stamped, along with its required dimensions and tolerances.

3.5.2 Forces on the tool and tool motion

3.5.2.1 contact force, F_c : The force, in newtons, applied to the stamping tool in the direction perpendicular to the sheet plane.

3.5.2.2 feed speed, v_f : The instantaneous velocity, in metres per minute, of the feed motion of the edge plane of the stamping tool in a direction perpendicular to the sheet plane.

4 Test specimens

4.1 Shape and state of the test specimens

The following types of test specimen can be prepared by the machining processes described in this International Standard:

- rectangular bars;
- notched rectangular bars;
- rectangular plates;
- curvilinear test specimens (e.g. dumb-bells);
- discs.

The exact shape, dimensions and tolerances of the test specimens shall conform to the standard for the particular test method in question. The machined surfaces and edges of the finished specimens shall be free of visible flaws, scratches or other imperfections when viewed with a low-power magnifying glass (approximately $\times 5$ magnification).

Rectangular bars shall be free of twist and shall have perpendicular pairs of parallel surfaces. The surfaces and edges shall be free from scratches, pits, sink marks and flashes. Each specimen shall be checked for conformity with these requirements by visual observation against straight-edges, squares and flat plates, and by measuring with micrometer callipers.

The requirements on the quality of the edges of disc-shaped specimens used for impact-penetration tests are less rigorous than those for tensile-test specimens.

Any specimen showing a measurable or observable departure from the requirements given above shall be rejected or machined to proper size and shape before testing.

4.2 Preparation of test specimens

The test specimens shall be machined from plates or sheets made from the material to be tested by compression moulding, injection moulding, casting, polymerizing *in situ*, extrusion or other processing operations to produce semifinished products. Plates may also be obtained in an appropriate manner from finished products. If the sample from which the specimens are prepared is not isotropic, prepare test specimens with their main axis parallel to and perpendicular to the main orientation axis. In all cases, the exact conditions for producing the test specimens, and the position and orientation of the specimens within the samples, shall be agreed upon by the interested parties, and such details shall be described in the test report.

NOTE 1 Attention is drawn to the fact that the room temperature and the temperature of the material during the machining may influence the properties of the specimen.

5 Machinery and tools

For preparing test specimens from plastics materials and for notching of finished specimens, the machines mentioned in 5.1 to 5.5 can be used (see also clause 3). Recommended machining conditions for various specimen shapes and specimen materials are given in table 1. Any required conditions for preparation of test specimens by machining will be specified for each material in part 2 of the appropriate ISO material standard. The conditions given in table 1 for machining notches have also been found to give satisfactory results for numerous materials; however, because of the wide variety of materials tested, other conditions may also be appropriate.

5.1 Milling cutters

These can be used to prepare dumb-bell test specimens and rectangular bars. They may contain one tooth or a number of teeth arranged in a manner described in ISO 3855 and may cut at variable speeds (at high speeds, for instance, in the case of copy milling machines). They can also be used to cut notches in rectangular specimens. In this case, more than one tooth shall be used only if the notches can be made with the same quality as with one tooth.

5.2 Slicing or sawing machines

These may be used to prepare rectangular bar or plate test specimens. They can be equipped with a circular or a band saw, or with a circular disc, the edge of which is coated with an abrasive material such as diamond or cubic boron nitride.

5.3 Tubular cutting machines

These are used to prepare disc test specimens from flat plates or sheet material. The cutting edge of this kind of tool may be saw-toothed or coated with an abrasive material.

5.4 Lathes

These can be used for the same purpose as indicated in 5.3, i.e. for cutting disc test specimens from roughly pre-shaped packs of individual sheets.

5.5 Planing machines

These can be used to cut finished sawed or sliced rectangular bars and to cut notches.

5.6 Stamping tools

Stamping tools are suitable for preparing test specimens of any shape from thin sheets made of materials of adequate ductility.

5.7 Broaching tools

These can be used for notching. They may be hand-operated or machine-driven.

6 Procedure

The machining speed is dependent on the material being tested and shall be such that overheating of the material is avoided. This is particularly important in the case of thermoplastic materials. If the use of a cooling agent is necessary, this will be stated in part 2 of the appropriate ISO material standard. The use of a cooling agent shall have no deleterious effect on the material being machined (see also table 1). Fine abrasives may be used to achieve a smooth finish. In the case of tools with edges coated with diamond, cubic boron nitride or another abrasive material, ISO 3017, ISO 6104, ISO 6106 and ISO 6168 should be considered.

NOTE 2 When machining specimens, care should be taken to avoid skin contact and inhalation of dust, as dust may cause irritation.

6.1 Preparation of dumb-bell specimens

Prepare such specimens by low-speed milling with a hand-controlled milling tool or, preferably, by high-speed copy milling using the conditions given in table 1.

Examine the milled surfaces and edges of the finished test specimens with a magnifying glass having an approximately $\times 5$ magnification for the presence of flaws, scratches and other imperfections. After cutting a maximum of 500 specimens, examine the cutting edge with the aid of a microscope or profile projector with a $\times 50$ to $\times 100$ magnification.

6.2 Preparation of rectangular test specimens by sawing or cutting with an abrasive disc

The detailed conditions used in these methods are given in table 1. Prepare the test specimens by sawing only if there are no particular requirements regarding the quality of the specimen surfaces, or if the surfaces are to be subsequently finished by another method such as milling or planing. In the latter case, examine the surfaces as specified in 6.1.

6.3 Preparation of disc-shaped test specimens

In general, disc specimens are used to perform impact-penetration tests. In such cases, imperfections in the machined surfaces have no serious influence on the test results. Prepare such specimens using the conditions given in table 1 and ensure that the plane surfaces of the specimens are smooth and free from flaws.

6.4 Stamping out test specimens of any shape

Use this method for the preparation of test specimens only if the material in question is sufficiently soft and the specimens are to be made from sufficiently thin sheets. The specimen is stamped from the sheet using a single stroke of a knife-edged punch of appropriate shape and dimensions. The cutting edge of the punch shall be sufficiently sharp and free from notches. The sheet shall be supported on a slightly yielding material with a smooth surface (for example leather, rubber or good-quality cardboard) on a flat, rigid base.

The criterion for the applicability of this method is the quality of the specimen edges and surfaces as revealed by examination using the method outlined in 6.1.

6.5 Notching finished test specimens by milling or broaching

Notching may be carried out with the aid of a milling or broaching machine or a lathe, preferably with a

single-tooth cutter. Use a tool having a cutting edge made of high-speed steel, hardened steel or diamond. Use a multi-tooth cutter only if notches can be prepared having the same quality as notches made with a single-tooth cutter. For specimens prepared by stamping, machine the notch in a secondary operation (i.e. the notch shall not be stamped).

In preparing notches, the use of abrasives is not permissible.

For milling, choose the feed rate so that the thickness d_s of the shavings is from 0,003 mm to 0,07 mm (see figures 2 and 3). The thickness d_s is given, in millimetres, by the equation

$$d_s = v_f^2 (n^2 \cdot R)$$

where

v_f is the feed speed, in millimetres per minute;

n is the rotary speed of the tool, in revolutions per minute;

R is the distance, in millimetres, between the axis of the milling machine and the tip of the cutter.

It is essential that close tolerances are established on the contour and radius of the notch because these parameters largely determine the degree of stress concentration at the base of the notch. To obtain reproducible results, carefully grind and hone the cutting edge to ensure sharpness and freedom from nicks and burrs.

Before the first use and after cutting about 500 notches, or more often if the cutter has been used to notch a hard abrasive material, inspect the cutter for sharpness, absence of nicks, correct tip radius and correct tip contour. If the radius and contour do not fall within the specified limits, replace the cutter by a newly sharpened and honed one.

A microscope or profile projector with a $\times 50$ to $\times 100$ magnification is suitable for checking the cutter and the notch. In the case of single-tooth cutters, the contour of the tip of the cutting tool may be checked instead of the contour of the notch in the specimen, provided that, for the type of notch produced, the two correspond or that a definite relationship exists between them. There is some evidence that notches cut by the same cutter in widely differing materials may differ in contour.

In the case of transparent materials, it is often possible to detect undesirable changes in the specimen

Examine the milled surfaces and edges of the finished test specimens with a magnifying glass having an approximately $\times 5$ magnification for the presence of flaws, scratches and other imperfections. After cutting a maximum of 500 specimens, examine the cutting edge with the aid of a microscope or profile projector with a $\times 50$ to $\times 100$ magnification.

6.2 Preparation of rectangular test specimens by sawing or cutting with an abrasive disc

The detailed conditions used in these methods are given in table 1. Prepare the test specimens by sawing only if there are no particular requirements regarding the quality of the specimen surfaces, or if the surfaces are to be subsequently finished by another method such as milling or planing. In the latter case, examine the surfaces as specified in 6.1.

6.3 Preparation of disc-shaped test specimens

In general, disc specimens are used to perform impact-penetration tests. In such cases, imperfections in the machined surfaces have no serious influence on the test results. Prepare such specimens using the conditions given in table 1 and ensure that the plane surfaces of the specimens are smooth and free from flaws.

6.4 Stamping out test specimens of any shape

Use this method for the preparation of test specimens only if the material in question is sufficiently soft and the specimens are to be made from sufficiently thin sheets. The specimen is stamped from the sheet using a single stroke of a knife-edged punch of appropriate shape and dimensions. The cutting edge of the punch shall be sufficiently sharp and free from notches. The sheet shall be supported on a slightly yielding material with a smooth surface (for example leather, rubber or good-quality cardboard) on a flat, rigid base.

The criterion for the applicability of this method is the quality of the specimen edges and surfaces as revealed by examination using the method outlined in 6.1.

6.5 Notching finished test specimens by milling or broaching

Notching may be carried out with the aid of a milling or broaching machine or a lathe, preferably with a

single-tooth cutter. Use a tool having a cutting edge made of high-speed steel, hardened steel or diamond. Use a multi-tooth cutter only if notches can be prepared having the same quality as notches made with a single-tooth cutter. For specimens prepared by stamping, machine the notch in a secondary operation (i.e. the notch shall not be stamped).

In preparing notches, the use of abrasives is not permissible.

For milling, choose the feed rate so that the thickness d_s of the shavings is from 0,003 mm to 0,07 mm (see figures 2 and 3). The thickness d_s is given, in millimetres, by the equation

$$d_s = v_f^2 (n^2 \cdot R)$$

where

v_f is the feed speed, in millimetres per minute;

n is the rotary speed of the tool, in revolutions per minute;

R is the distance, in millimetres, between the axis of the milling machine and the tip of the cutter.

It is essential that close tolerances are established on the contour and radius of the notch because these parameters largely determine the degree of stress concentration at the base of the notch. To obtain reproducible results, carefully grind and hone the cutting edge to ensure sharpness and freedom from nicks and burrs.

Before the first use and after cutting about 500 notches, or more often if the cutter has been used to notch a hard abrasive material, inspect the cutter for sharpness, absence of nicks, correct tip radius and correct tip contour. If the radius and contour do not fall within the specified limits, replace the cutter by a newly sharpened and honed one.

A microscope or profile projector with a $\times 50$ to $\times 100$ magnification is suitable for checking the cutter and the notch. In the case of single-tooth cutters, the contour of the tip of the cutting tool may be checked instead of the contour of the notch in the specimen, provided that, for the type of notch produced, the two correspond or that a definite relationship exists between them. There is some evidence that notches cut by the same cutter in widely differing materials may differ in contour.

In the case of transparent materials, it is often possible to detect undesirable changes in the notch contour.

by means of photoelastic effects. For example, undesirable heating or melting caused by machining, especially of injection-moulded specimens, becomes visible by virtue of distinct changes in coloured interference lines or areas within the zone near the machined surface.

NOTE 3 Experience using notched specimens has shown that there are materials (e.g. PMMA, PC) for which the measured values obtained in tests using such specimens decrease gradually in spite of the fact that the cutter is optically satisfactory. In such cases, it is recommended that the cutter be checked using a reference material.

7 Test report

The test report shall include the following information:

- a) a reference to this International Standard;
- b) a description of the material tested and of the sample from which the test specimens were machined (shape, method of preparation, orientation, etc.);
- c) a precise description of the position and orientation of the test specimens as taken from a semifinished or finished product;
- d) the dimensions of the test specimens;
- e) the method of machining used;
- f) the machining conditions used (see table 1);
- g) any other relevant details.

Table 1 — Recommended machining conditions for four types of test specimen and for notches

Material	Method of machining	Rotational speed n tr/min	Geometry of tool				Number of teeth z	Tool motions			Coolant	
			Diameter $2R$ mm	Cutting edge angle α_c	Back clearance α_b	Side clearance α_s		Cutting speed v_c m/min	Feed speed v_f m/min	Feed path λ mm		Cutting depth a mm
1) Dumb-bell specimen (see 6.1)												
Thermoplastics Thermosets	Medium-speed milling	180 to 500	125 to 150	5 to 15	5 to 20	—	10 to 16	70 to 250 70 to 250	Slowly Slowly	—	1 to 5 1 to 5	None, air or water
Thermoplastics Thermosets	High-speed copy milling	8 000 to 30 000 20 000	5 to 20 15 to 20	10 to 15 10 to 15	5 to 20 5 to 20	—	4 to 8 4 to 8	125 to 2 000 100 to 1 500	Slowly Slowly	—	0,2 0,5	Air or water
2) Rectangular specimen (see 6.2)												
Thermoplastics Thermosets	Sawing with a circular saw	1 000 to 2 000 1 000 to 2 000	50 to 150 50 to 150	—	—	—	30 to 100 50 to 150	150 to 1 000 150 to 1 000	Medium Medium	—	—	None or air
Thermoplastics Thermosets	Sawing with a band saw	—	—	—	—	—	as for circular saw	3 to 15 3 to 15	Medium Medium	—	—	None or air
Thermoplastics Thermosets	Cutting with an abrasive disc	2 000 to 13 000 2 000 to 13 000	50 to 150 50 to 150	—	—	—	—	1 000 to 2 000 1 000 to 2 000	Slowly Slowly	—	—	Air or water
3) Disc-shaped specimen (see 6.3)												
Thermoplastics Thermosets	Cutting with a circular-saw-like cutter	100 to 200 100 to 200	40 to 100 40 to 100	—	—	—	30 to 100 30 to 100	10 to 100 10 to 100	Medium Medium	—	—	None or air
Thermoplastics Thermosets	Cutting with a circular abrasive cutter	300 to 1 500 300 to 1 500	40 to 100 40 to 100	—	—	—	—	100 to 200 100 to 200	Slowly Slowly	—	—	Air or water
Thermoplastics Thermosets	Cutting with a single-tooth milling cutter	100 to 200 100 to 200	40 to 100 40 to 100	5 to 15 5 to 15	5 to 20 5 to 20	—	1 1	10 to 100 10 to 100	Slowly Slowly	—	—	None or air
Thermoplastics Thermosets	Turning with a lathe	500 to 1 000 500 to 1 000	20 to 100 20 to 100	5 to 15 5 to 15	5 to 20 5 to 20	—	1 1	30 to 300 30 to 300	Slowly Slowly	—	—	None or air
4) Stamped specimens of any shape (see 6.4)												
Thermoplastics Thermosets	Stamping from thin sheets	—	—	—	—	—	—	—	Slowly by pressure	—	—	None None
5) Cutting notches (see 6.5)												
Thermoplastics Thermosets	Medium-speed milling	200 to 1 000 200 to 1 000	60 to 80 60 to 80	2 to 7 2 to 7	2 to 7 2 to 7	—	1 1	50 to 250 50 to 250	0,07 to 0,2 0,07 to 0,2	1 to 2 1 to 2	0,2 to 2 0,2 to 2	Air or water
Thermoplastics Thermosets	Broaching	—	—	2 to 7 2 to 7	2 to 7 2 to 7	—	1 1	12 to 20 12 to 20	Slowly Slowly	—	0,1 to 0,3 0,1 to 0,3	Air or water

NOTE — These machining conditions may vary, depending on the specific materials and tools used. The machining conditions used should be those which provide specimens conforming to the specified dimensions and free of flaws when examined under the specified magnification.

Particular machining conditions are reported in part 2 of the designation standard for the material concerned.

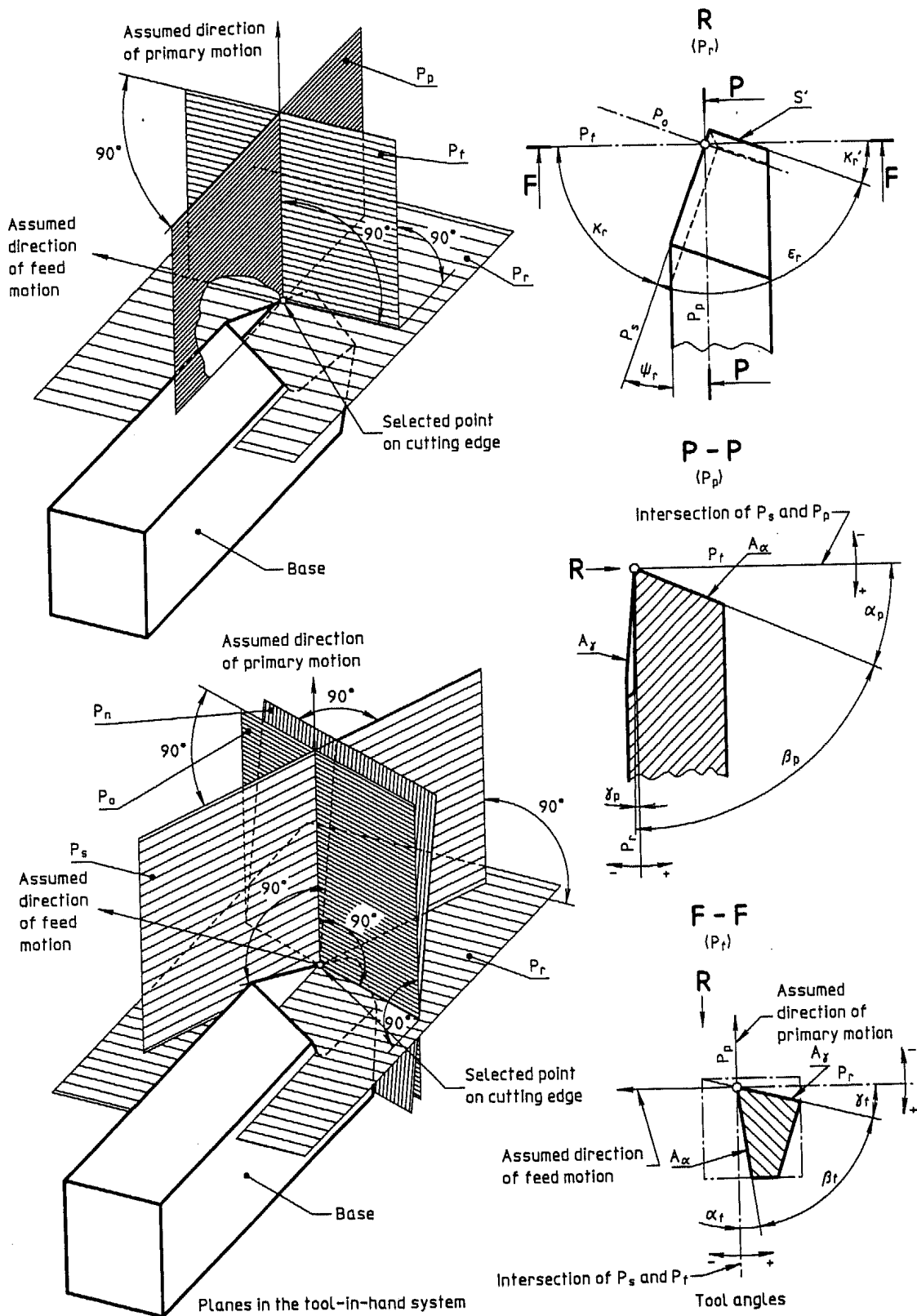
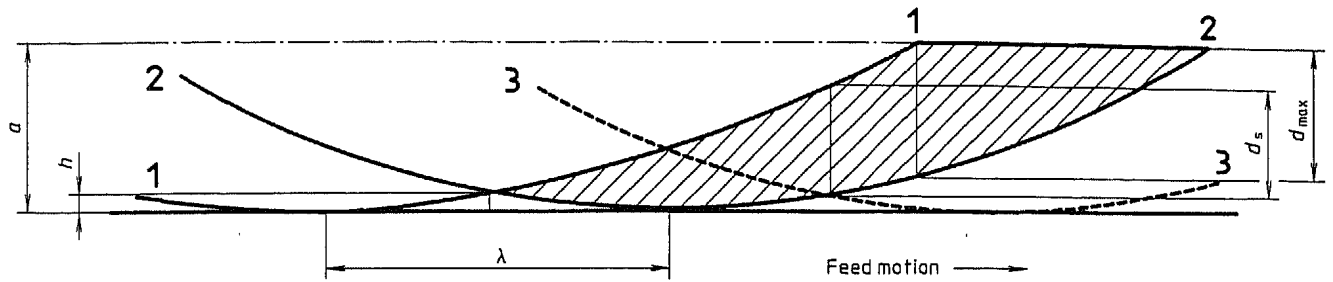

Figure 1 — Geometry of the active part of cutting tools



a = cutting depth
 λ = feed path
 h = roughness
 1, 2, 3 = successive cuts

d_s = thickness of chip
 d_{max} = maximum thickness of chip

Figure 2 — Shape of milling chips

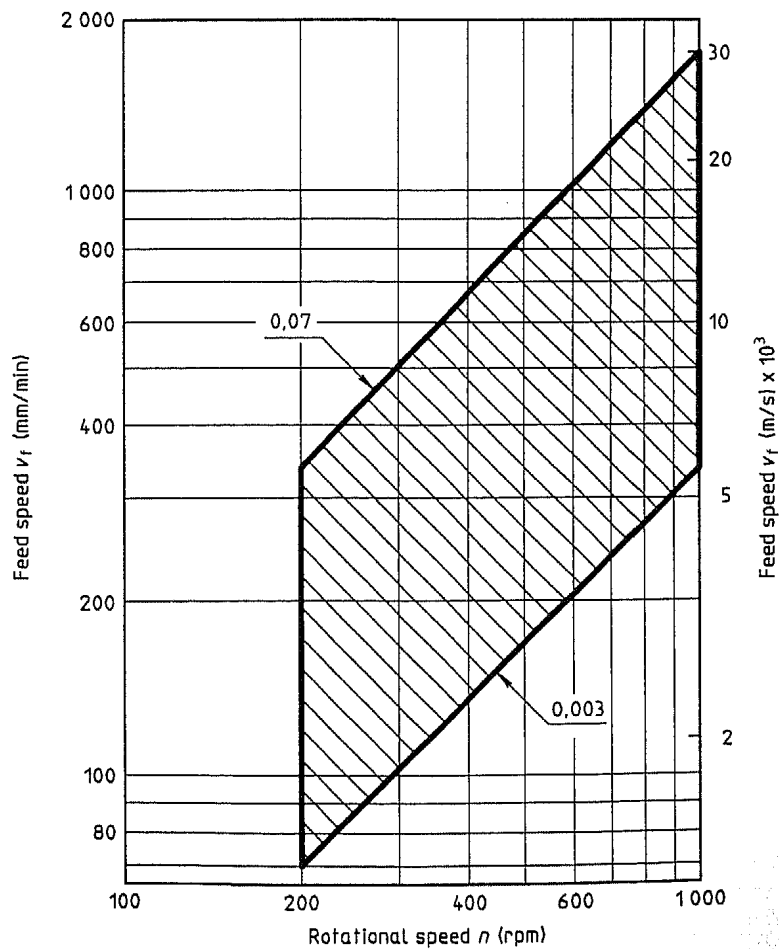
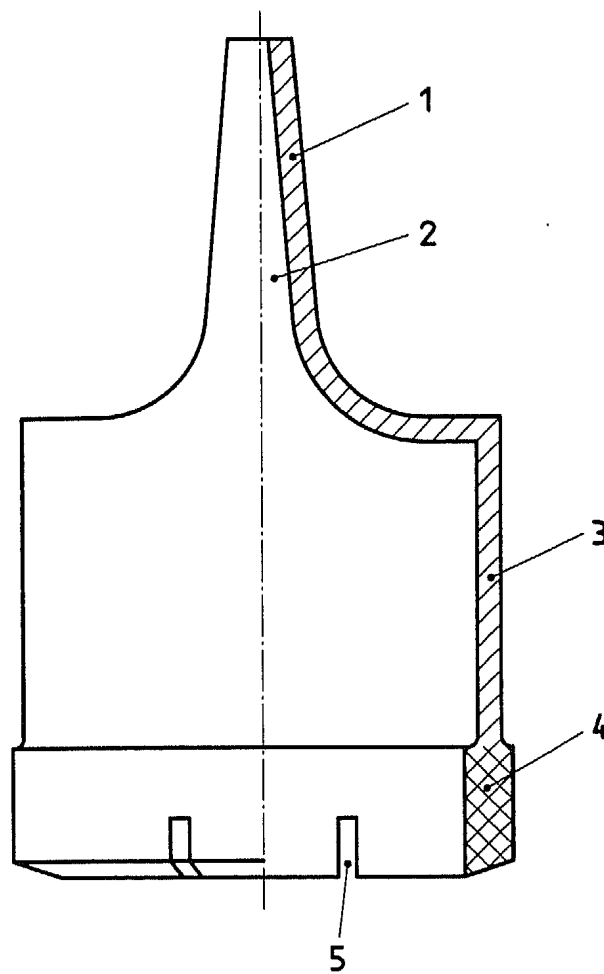

Figure 3 — Chip thickness d_s in the range between 0,003 mm and 0,07 mm versus rotational speed n and feed speed v_f of a milling machine ($R = 40$ mm)



- 1 Cylindrical or conical fixing shank
- 2 Axial cooling-water feed channel
- 3 Body of the cutter
- 4 Abrasive sleeve (slightly thicker than the body of the cutter)
- 5 Drainage holes for cooling water and dust

Figure 4 — Example of a circular cutter (half-section of a diamond-edged cutter)

Annex A (informative)

Bibliography

- | | |
|---|--|
| <p>[1] ISO 291:1977, <i>Plastics — Standard atmospheres for conditioning and testing.</i></p> <p>[2] ISO 293:1986, <i>Plastics — Compression moulding test specimens of thermoplastic materials.</i></p> <p>[3] ISO 294:1975, <i>Plastics — Injection moulding test specimens of thermoplastic materials.</i></p> <p>[4] ISO 295:1991, <i>Plastics — Compression moulding of test specimens of thermosetting materials.</i></p> | <p>[5] ISO 468:1982, <i>Surface roughness — Parameters, their values and general rules for specifying requirements.</i></p> <p>[6] ISO 2557-1:1989, <i>Plastics — Amorphous thermoplastics — Preparation of test specimens with a specified maximum reversion — Part 1: Bars.</i></p> <p>[7] ISO 2557-2:1986, <i>Plastics — Amorphous thermoplastics — Preparation of test specimens with a specified reversion — Part 2: Plates.</i></p> <p>[8] ISO 3167:1993, <i>Plastics — Multipurpose test specimens.</i></p> |
|---|--|

ICS 83.080.00

Descriptors: plastics, test specimens, specimen preparation, machining.

Price based on 11 pages.
