

INTERNATIONAL
STANDARD

ISO
2729

Second edition
1995-11-15

Woodworking tools — Chisels and gouges

Outils pour le travail du bois — Ciseaux et gouges



Reference number
ISO 2729:1995(E)

Foreword

ISO (the International Organization for Standardization) is a worldwide federation of national standards bodies (ISO member bodies). The work of preparing International Standards is normally carried out through ISO technical committees. Each member body interested in a subject for which a technical committee has been established has the right to be represented on that committee. International organizations, governmental and non-governmental, in liaison with ISO, also take part in the work. ISO collaborates closely with the International Electrotechnical Commission (IEC) on all matters of electrotechnical standardization.

Draft International Standards adopted by the technical committees are circulated to the member bodies for voting. Publication as an International Standard requires approval by at least 75 % of the member bodies casting a vote.

International Standard ISO 2729 was prepared by Technical Committee ISO/TC 29, *Small tools*.

This second edition cancels and replaces the first edition (ISO 2729:1973), which has been technically revised.

Annex A of this International Standard is for information only.

© ISO 1995

All rights reserved. Unless otherwise specified, no part of this publication may be reproduced or utilized in any form or by any means, electronic or mechanical, including photocopying and microfilm, without permission in writing from the publisher.

International Organization for Standardization
Case Postale 56 • CH-1211 Genève 20 • Switzerland

Printed in Switzerland

Woodworking tools — Chisels and gouges

1 Scope

This International Standard specifies the characteristics of chisels and gouges for woodworking.

2 Nomenclature

See table 1.

Table 1

Type	Illustration															
Firmers and butt chisels, bevel edged and plain																
Firmers gouges (half curved)																
<p>Key</p> <table border="0"> <tr> <td>1 Blade</td> <td>6 Out-Cannel</td> <td>11 Bolster</td> </tr> <tr> <td>2 Cutting edge</td> <td>7 In-Cannel</td> <td>12 Tang</td> </tr> <tr> <td>3 Face</td> <td>8 Bevel</td> <td>13 Handle</td> </tr> <tr> <td>4 Back</td> <td>9 Shoulder</td> <td>14 Reinforcing ferrule</td> </tr> <tr> <td>5 Cannel</td> <td>10 Neck</td> <td>15 Reinforcing hoop</td> </tr> </table>		1 Blade	6 Out-Cannel	11 Bolster	2 Cutting edge	7 In-Cannel	12 Tang	3 Face	8 Bevel	13 Handle	4 Back	9 Shoulder	14 Reinforcing ferrule	5 Cannel	10 Neck	15 Reinforcing hoop
1 Blade	6 Out-Cannel	11 Bolster														
2 Cutting edge	7 In-Cannel	12 Tang														
3 Face	8 Bevel	13 Handle														
4 Back	9 Shoulder	14 Reinforcing ferrule														
5 Cannel	10 Neck	15 Reinforcing hoop														
<p>NOTE — The illustrations are given as examples and shall neither limit nor influence the design of the tool.</p>																

3 Dimensions

3.1 Firmer chisels with tang, bevelled and plain (long type)

See figure 1 and table 2.

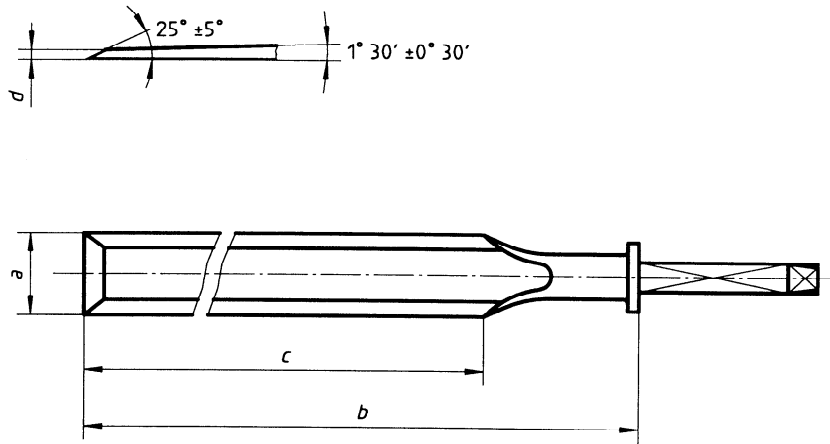

NOTE — The design of the tang is left to the manufacturer's decision. It shall allow the tool to withstand the tests of clause 5 without failure.

Figure 1

Table 2

a js 15		b ¹⁾ min.	c min.	d min.
mm	in	mm		
(2)	—	109	78	3,5
3	1/8	110	79	3,5
4	—	112	80	2,1
(5)	3/16	113	81	2,1
6	1/4	115	82	2,1
8	5/16	118	84	2,1
10	3/8	121	86	2,1
12	—	124	88	2,1
(13)	1/2	125	89	2,3
14	9/16	127	90	2,3
(15)	—	128	91	2,4
16	5/8	130	92	2,4
18	—	133	94	2,6
(19)	3/4	134	95	2,6
20	—	136	96	2,6
(22)	7/8	139	98	2,8
25	1	143	101	2,9
(28)	1 1/8	148	104	2,9
(30)	—	150	106	3,1
32	1 1/4	154	108	3,1
(35)	1 3/8	158	111	3,3
(38)	1 1/2	160	114	3,3
40	—	166	116	3,5

NOTE — Secondary series given in parentheses.

1) $b \text{ min.} = 106 + 1,5a$ (rounded to lower millimetre).

3.2 Butt chisels with tang, bevelled and plain (short type)

See figure 2 and table 3.

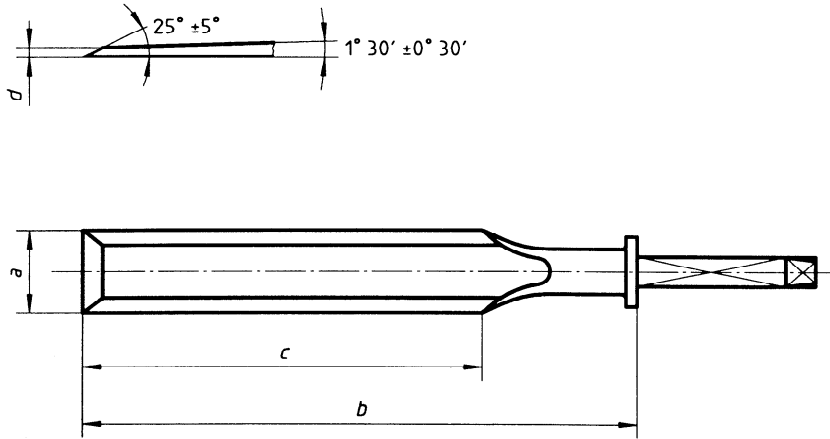

NOTE — The design of the tang is left to the manufacturer's decision. It shall allow the tool to withstand the tests of clause 5 without failure.

Figure 2

Table 3

<i>a</i> js 15		<i>b</i> min.	<i>c</i> min.	<i>d</i> min.
mm	in	mm		
6	1/4	104	76	2,1
10	3/8	107	76	2,1
(13)	1/2	109	76	2,3
16	5/8	111	76	2,4
(19)	3/4	113	76	2,6
25	1	118	76	2,9
32	1 1/4	122	76	3,1
(38)	1 1/2	127	76	3,1
50	2	135	76	3,5

NOTE — Secondary series is given in parentheses.

3.3 Firmer gouges

See figure 3 and table 4.

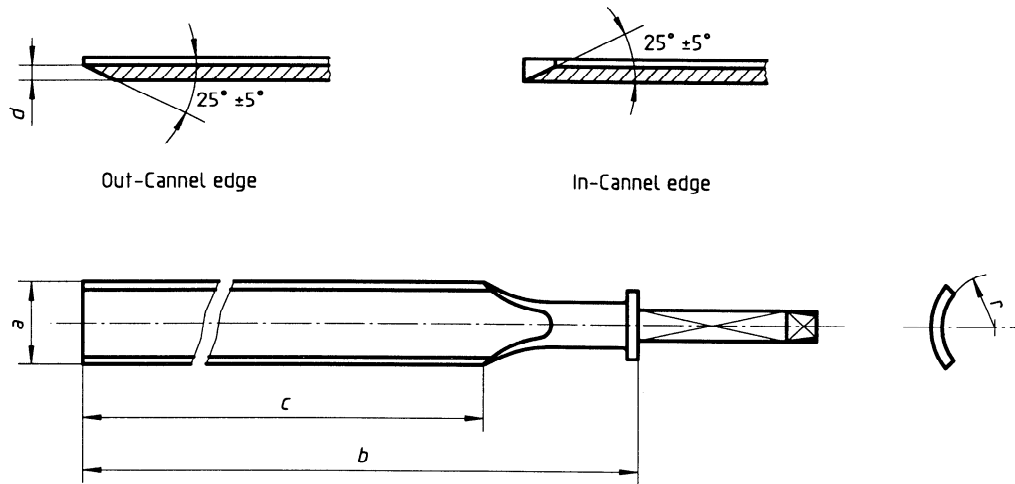

NOTES

- 1 The design of the tang is left to the manufacturer's decision. It shall allow the tool to withstand the tests of clause 5 without failure.
- 2 There are many shapes of gouge section. The gouge shown above is a half curved shape section gouge.

Figure 3

Table 4

a		b ¹⁾	c ²⁾	d	r	
js 15		min.	min.	min.	nom.	tol.
mm	in	mm				
(3)	1/8	110	79	3,5	3	± 0,45
6	1/4	115	82	2,1	4	± 0,6
8	5/16	118	84	2,1	5	± 0,6
10	3/8	121	86	2,1	6	± 0,6
12	1/2	124	88	2,1	7	± 0,6
(13)	—	125	89	2,3	7	± 0,75
15	—	128	91	2,4	8	± 0,75
(16)	5/8	130	92	2,4	9	± 0,75
18	—	133	94	2,6	10	± 0,75
(19)	—	134	95	2,6	11	± 0,9
20	3/4	136	96	2,6	12	± 0,9
(22)	7/8	139	98	2,8	13	± 0,9
25	1	143	101	2,9	14	± 0,9
(30)	—	150	106	3,1	16	± 0,9
(32)	1 1/4	154	108	3,1	18	± 0,9

NOTE — Secondary series is given in parentheses.

1) $b \text{ min.} = 106 + 1,5a$ (rounded to lower millimetre).

2) $c \text{ min.} = 76 + 1,1a$ (rounded to lower millimetre).

4 Technical specifications

4.1 Blade

The chisels and gouges shall have dimensions in conformity with those shown in 3.1 to 3.3. The non-specified shapes and dimensions shall be such that the tools can withstand loads to which they will be subjected during normal use.

4.1.1 Material

The blades of chisels and gouges specified in this International Standard shall be manufactured from a material which, taking into account the stated hardness, gives a cutting edge quality the same as, or greater than tool steel with an analysis given in table 5 (for guidance only).

Table 5

Limit	C	Si	Mn	P	S
min.	0,90 %	0,15 %	0,25 %	—	—
max.	1,25 %	0,25 %	0,40 %	0,035 %	0,035 %

After heat treatment, the blades shall have a hardness of 55 HRC to 61 HRC for $a \leq 8$ mm and 58 HRC to 61 HRC for $a > 8$ mm. This hardness is valid at a minimum distance equal to $2/3$ of length c measured from the cutting edge.

4.1.2 Cutting edge

The cutting edge shall be ground sharp and ready for final honing. The edge shall be at 90° to the centre line of the blade.

4.1.3 Bolster and neck

The bolster and neck shall be concentric with the centre line of the blade, and shall have such a form and size that they give good support to the handle. It shall not have sharp corners that can damage the handle.

4.1.4 Tang

The tang shall have a shape which provides a good fit in the handle. It shall be of such a design as to withstand loading in normal use, without failure. It shall be concentric with the axis of the blade.

4.1.5 Finish

For chisels and gouges, the face, back and sides of the blade shall be finely ground or have an equivalent finish.

a) For the out-cannel edge gouges, the face shall be finely ground or have an equivalent finish.

b) For the in-cannel edge gouges, the back shall be finely ground or have an equivalent finish.

After finishing, a suitable protection shall be applied to prevent rusting.

4.2 Handle

4.2.1 Shape

The handle shall be designed to give a good grip. It shall not have sharp corners or irregularities which might be hazardous during use. The dimensions of the handle shall be in proportion to those of the blade in order that the tool be well balanced.

4.2.2 Material

The handle shall be made from a material having the necessary strength to withstand impact and bending loads during normal use. Wooden handles for tanged tools may have a reinforcing hoop.

4.2.3 Handle fixing to blade

The handle shall be securely attached to the blade and shall withstand the tests specified in clause 5.

5 Test methods

5.1 Blade

5.1.1 Test for soundness

Every blade shall be capable of passing the following test for soundness, at the completion of which it shall show no sign of fracture or flaw.

A suitable block of lead shall be placed on a bench or table. The blade shall be held by tang or neck, between the thumb and fingers; the hand shall then be raised and brought down quickly, using the force of wrist and elbow to strike the flat of the blade a sharp blow against the top face of the lead block. This manually applied sharp blow shall be repeated six times consecutively.

5.1.2 Bending test (chisels, see figure 4)

To determine the permanent deflection of the chisel blade, the distance between the fixture base and two points A and B on the chisel are measured before and after applying the load in accordance with tables 6 and 7.

The deflection is measured by using an indicator clock or other suitable measuring instrument. The permanent deflection is calculated as the difference between the two readings. The maximum permanent deflection allowed is 1 mm at point A and 3 mm at point B.

The measuring points shall be located as follows:

A, at the highest point of the bolster;

B, 75 mm from the front end of the handle.

The bending load, P , shall be applied at 75 mm from the front end of the handle with the chisel held in the fixture as shown in figure 4. Bending load, P , for firmer chisels is given in table 6 and for butt chisels in table 7. Values for load P can also be calculated from the following formula:

$$P = \frac{ad'^2\sigma}{6L}$$

where

P is the load in decanewtons;

L is as shown in figure 4, i.e.:

$$L = b - (21 + 5) + 75 = b + 49, \text{ in millimetres;}$$

σ is the tensile strength = 120 daN/mm²;

a is the width of the blade, in millimetres;

d' is the corrected value of the thickness of the blade, in millimetres, i.e.:

$$d' = d \text{ min. } \times f$$

where d min. values are taken from tables 2, 3 or 4, and where f is a correction factor equal to 0,88.

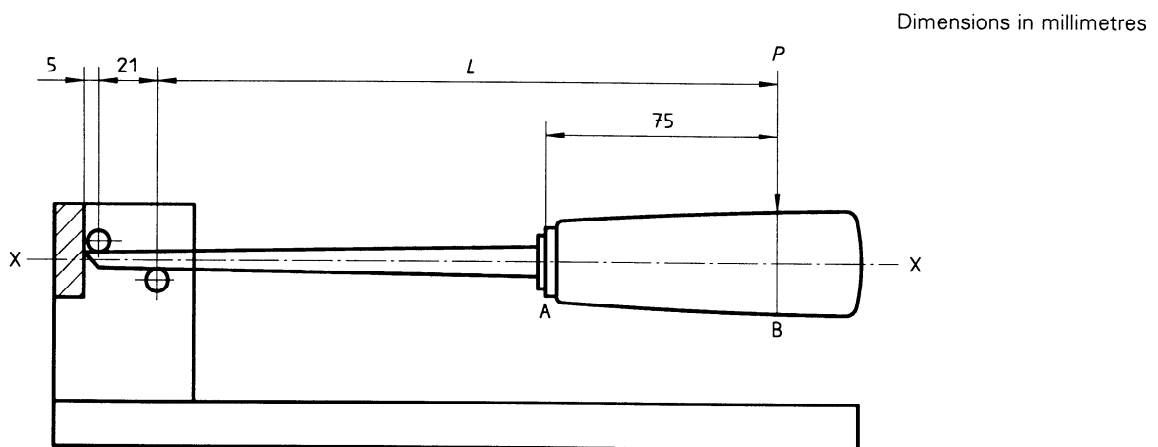

Figure 4

Table 6 — Bending load for firmer chisels

Width of blade <i>a</i>	Bending load <i>P</i>
mm	daN
2	2,36
3	3,58
4	1,69
5	2,1
6	2,49
8	3,27
10	4,01
12	4,73
13	6,12
14	6,51
15	7,56
16	7,97
18	10,35
19	10,87
20	11,31
22	14,2
25	16,96
28	18,51
30	22,43
32	23,46
35	28,51
38	30,66
40	35,7

Table 7 — Bending load for butt chisels

Width of blade <i>a</i>	Bending load <i>P</i>
mm	daN
6	2,67
10	4,37
13	6,12
16	8,92
19	12,27
25	17,72
32	25,32
38	36,97
50	51,55

5.2 Test for strength of handle

This test is applicable to both chisels and gouges.

The chisel or gouge with handle, with its cutting edge completely removed, shall be placed vertically in a sleeve. It must be laid on a base treated to 60 HRC minimum.

A metal weight of 5 kg with a flat face shall fall freely on to the handle from a height. Values for the height drop H , according to the width of blade, are given in table 8.

The weight shall be guided during the drop.

The chisel (gouge) handle, although it may show deformation in the shape of a mushroom on its end, shall still be perfectly usable after the required number of blows given in table 8; that is to say, the handle shall neither split nor break and the reinforcing hoop, if fitted, shall still be in place.

For guidance, the sleeve may be manufactured as indicated in figure 5.

NOTE 1 When testing a plastic handle, the frequency of blows from the machine may be reduced so has to cause no more heating of the handle than would be caused by normal use in practice.

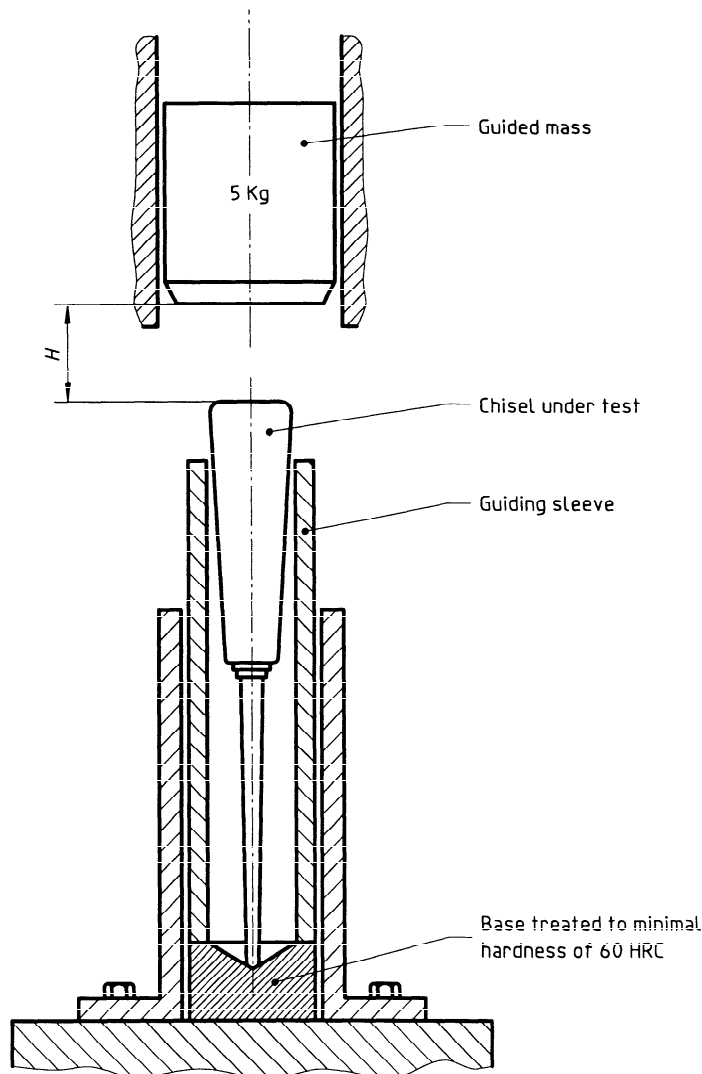

Figure 5

After the impact test, the chisels and gouges shall be subjected to an axial pull-off test and a torsional test and shall withstand the loads given in table 8. There shall be no indication of any looseness of the handle after these tests.

Table 8

Width of the blade <i>a</i>	Height of drop <i>H</i>	Number of blows	Corresponding energy	Proof load for handle/blade pull-apart	Handle/blade proof torque
mm	m		J	N	N·m
$a \leq 10$	0,2	12	120	800	10
$10 < a \leq 20$	0,3	12	180	1 000	10
$a > 20$	0,4	12	240	1 200	10

Annex A

(informative)

Bibliography

- [1] ISO 286-2:1988, *ISO system of limits and fits — Part 2: Tables of standard tolerance grades and limit deviations for holes and shafts.*
- [2] ISO 6508:1986, *Metallic materials — Hardness test — Rockwell test (scales A - B - C - D - E - F - G - H - K).*

This page intentionally left blank

ICS 79.120.20

Descriptors: tools, hand tools, woodworking tools, chisels, blades, tool handles, specifications, dimensions, tests.

Price based on 12 pages
