

---

---

**Assembly tools for screws and nuts —  
Square drive sockets —**

Part 1:  
**Hand-operated sockets**

*Outils de manoeuvre pour vis et écrous — Douilles à carré  
conducteur femelle —*

*Partie 1: Douilles à main*



**COPYRIGHT PROTECTED DOCUMENT**

© ISO 2015

All rights reserved. Unless otherwise specified, no part of this publication may be reproduced or utilized otherwise in any form or by any means, electronic or mechanical, including photocopying, or posting on the internet or an intranet, without prior written permission. Permission can be requested from either ISO at the address below or ISO's member body in the country of the requester.

ISO copyright office  
Case postale 56 • CH-1211 Geneva 20  
Tel. + 41 22 749 01 11  
Fax + 41 22 749 09 47  
E-mail [copyright@iso.org](mailto:copyright@iso.org)  
Web [www.iso.org](http://www.iso.org)

Published in Switzerland

# Contents

Page

<b>Foreword</b> .....	<b>iv</b>
<b>1 Scope</b> .....	<b>1</b>
<b>2 Normative references</b> .....	<b>1</b>
<b>3 Tolerances for width across flats</b> .....	<b>1</b>
<b>4 Dimensions</b> .....	<b>1</b>
<b>5 Technical specifications</b> .....	<b>7</b>
<b>6 Designation</b> .....	<b>7</b>
<b>7 Marking</b> .....	<b>7</b>
<b>Bibliography</b> .....	<b>8</b>

## Foreword

ISO (the International Organization for Standardization) is a worldwide federation of national standards bodies (ISO member bodies). The work of preparing International Standards is normally carried out through ISO technical committees. Each member body interested in a subject for which a technical committee has been established has the right to be represented on that committee. International organizations, governmental and non-governmental, in liaison with ISO, also take part in the work. ISO collaborates closely with the International Electrotechnical Commission (IEC) on all matters of electrotechnical standardization.

The procedures used to develop this document and those intended for its further maintenance are described in the ISO/IEC Directives, Part 1. In particular the different approval criteria needed for the different types of ISO documents should be noted. This document was drafted in accordance with the editorial rules of the ISO/IEC Directives, Part 2 (see [www.iso.org/directives](http://www.iso.org/directives)).

Attention is drawn to the possibility that some of the elements of this document may be the subject of patent rights. ISO shall not be held responsible for identifying any or all such patent rights. Details of any patent rights identified during the development of the document will be in the Introduction and/or on the ISO list of patent declarations received (see [www.iso.org/patents](http://www.iso.org/patents)).

Any trade name used in this document is information given for the convenience of users and does not constitute an endorsement.

For an explanation on the meaning of ISO specific terms and expressions related to conformity assessment, as well as information about ISO's adherence to the WTO principles in the Technical Barriers to Trade (TBT), see the following URL: [Foreword — Supplementary information](#).

The committee responsible for this document is ISO/TC 29, *Small tools*, Subcommittee SC 10, *Assembly tools for screws and nuts, pliers and nippers*.

This third edition cancels and replaces the second edition (ISO 2725-1:2007), which has been technically revised.

The following main changes have been made with respect to the previous edition:

- a) additional widths across flat sizes not covered by ISO 272 included, in order to better reflect the current market situation;
- b)  $d_{3\min}$  calculated from maximum thread diameter  $D_{\max}$  (the largest nominal thread diameter found in current standards);
- c) the values of  $t_{\min}$  have been changed to the maximum thread diameter ( $t_{\min} = m_{\max} + 0,1$ ).

ISO 2725 consists of the following parts, under the general title *Assembly tools for screws and nuts — Square drive sockets*:

- *Part 1: Hand-operated sockets*
- *Part 2: Machine-operated sockets ('impact')*
- *Part 3: Machine-operated sockets ('non-impact')*

# Assembly tools for screws and nuts — Square drive sockets —

## Part 1: Hand-operated sockets

### 1 Scope

This part of ISO 2725 specifies dimensions, the designation, and the marking of hand-operated square drive sockets with operating end and having a hexagonal or double hexagonal form in accordance with ISO 1174-1.

NOTE 1 Hand-operated square drive sockets are listed under number 2 1 02 01 0 in ISO 1703.

NOTE 2 The figures in this part of ISO 2725 are given only as examples. They are not intended to influence the manufacturer's design.

### 2 Normative references

The following documents, in whole or in part, are normatively referenced in this document and are indispensable for its application. For dated references, only the edition cited applies. For undated references, the latest edition of the referenced document (including any amendments) applies.

ISO 691, *Assembly tools for screws and nuts — Wrench and socket openings — Tolerances for general use*

ISO 1174-1, *Assembly tools for screws and nuts — Driving squares — Part 1: Driving squares for hand socket tools*

ISO 1711-1, *Assembly tools for screws and nuts — Technical specifications — Part 1: Hand-operated wrenches and sockets*

ISO 4014, *Hexagon head bolts — Product grades A and B*

ISO 4032, *Hexagon regular nuts (style 1) — Product grades A and B*

### 3 Tolerances for width across flats

Tolerances for width across flats,  $s$ , shall be in conformity with the tolerances for socket openings given in ISO 691. Manufacturers are free to choose the series of deviations.

### 4 Dimensions

[Table 1](#) to [Table 5](#) give the dimensions, in millimetre, of sockets shown in [Figure 1](#) to [Figure 3](#) for driving squares of 6,3 to 25 (in accordance with ISO 1174-1).

NOTE Width across flats,  $s$ , are partly taken from ISO 272.

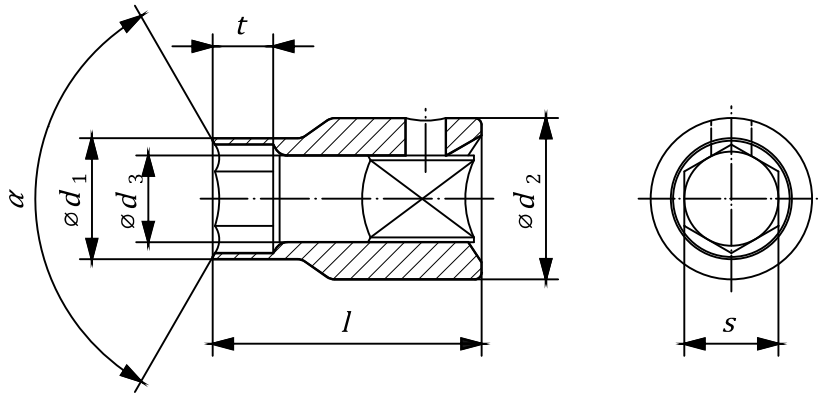

$\alpha \quad 115^\circ \leq \alpha \leq 150^\circ$

**Figure 1 — Sockets with  $d_1 < d_2$**

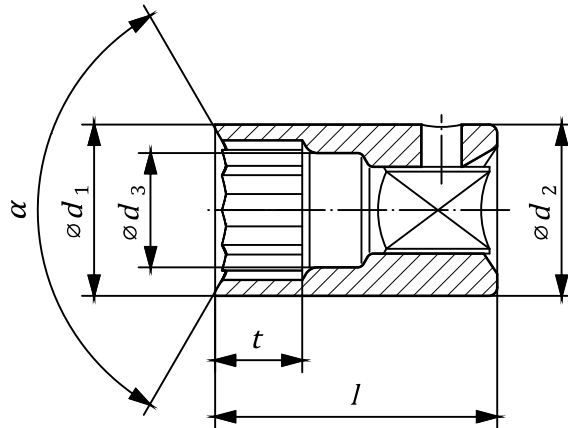

$\alpha \quad 115^\circ \leq \alpha \leq 150^\circ$

**Figure 2 — Sockets with  $d_1 = d_2$**

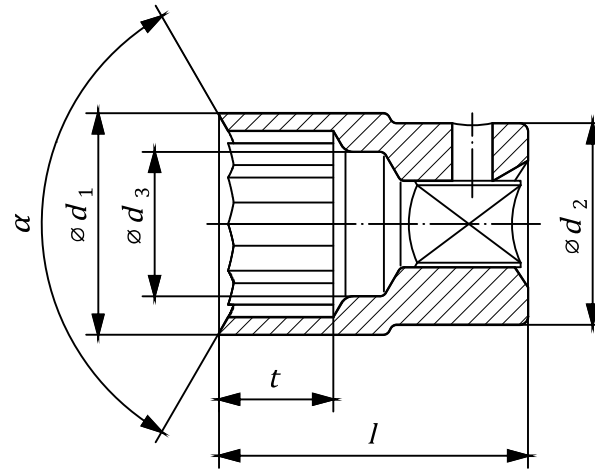

$\alpha \quad 115^\circ \leq \alpha \leq 150^\circ$

Figure 3 — Sockets with  $d_1 > d_2$

Table 1 — Square drive of 6,3

s	Dmax <sup>c</sup> mm	t <sup>a</sup> min. mm	d <sub>1</sub> max. mm	d <sub>2</sub> max. mm	d <sub>3</sub> <sup>b</sup> min. mm	l	
						max. Type A (normal) mm	min. Type B (long) mm
3,2	1,6	1,4	5,9	12,5	1,7	26	45
4	2	1,7	6,9	12,5	2,1	26	45
5	2,5	2,1	8,2	12,5	2,6	26	45
5,5	3	2,5	8,8	12,5	3,2	26	45
6 <sup>d</sup>	3,5 <sup>f</sup>	2,9	9,4	12,5	3,7	26	45
7	5	3,3	11	12,5	5,3	26	45
8	6	4,8	12,2	12,5	6,3	26	45
9 <sup>d</sup>	6 <sup>e</sup>	5,1	13,5	13,5	6,3	26	45
10	8	5,3	14,7	14,7	8,4	26	45
11	8 <sup>e</sup>	5,8	16	16	8,4	26	45
12 <sup>d</sup>	8	6,4	17,2	17,2	8,4	26	45

NOTE  $t_{\min}$  is interpolated for sizes not covered by ISO 4032 and ISO 4014.

<sup>a</sup>  $t_{\min} = m_{\max} + 0,1$ ; where  $m_{\max}$  is the maximum height of the nut, according to ISO 4032.

<sup>b</sup>  $d_{3\min} = D_{\max} \times 1,05$

<sup>c</sup> The maximum thread diameter  $D_{\max}$  is the largest nominal thread diameter found in current International Standards like, e.g. ISO 4014, ISO 4032, ISO 272.

<sup>d</sup> Nominal dimension not covered by ISO 272.

<sup>e</sup> Value determined in order to avoid reduction in hole clearance size.

<sup>f</sup> Value taken from DIN 934

Table 1 (continued)

s	Dmax <sup>c</sup> mm	t <sup>a</sup> min. mm	d <sub>1</sub> max. mm	d <sub>2</sub> max. mm	d <sub>3</sub> <sup>b</sup> min.	l	
					Bolt clearance hole mm	max.	min.
						Type A (normal) mm	Type B (long) mm
13	10	6,9	18,5	18,5	10,5	26	45
14 <sup>d</sup>	10	7,4	19,7	19,7	10,5	26	46
15 <sup>d</sup>	12	8,0	21,5	21,5	12,6	26	45
16	12 <sup>e</sup>	8,5	22	22	12,6	26	45

NOTE t<sub>min</sub> is interpolated for sizes not covered by ISO 4032 and ISO 4014.

a t<sub>min</sub> = m<sub>max</sub> + 0,1; where m<sub>max</sub> is the maximum height of the nut, according to ISO 4032.

b d<sub>3min</sub> = Dmax × 1,05

c The maximum thread diameter Dmax is the largest nominal thread diameter found in current International Standards like, e.g. ISO 4014, ISO 4032, ISO 272.

d Nominal dimension not covered by ISO 272.

e Value determined in order to avoid reduction in hole clearance size.

f Value taken from DIN 934

Table 2 — Square drive of 10

s	Dmax <sup>c</sup> mm	t <sup>a</sup> min. mm	d <sub>1</sub> max. mm	d <sub>2</sub> max. mm	d <sub>3</sub> <sup>b</sup> min.	l	
					Bolt clearance hole mm	max.	min.
						Type A (normal) mm	Type B (long) mm
7	5	3,3	11	20	5,3	32	44
8	6	4,8	12,2	20	6,3	32	44
9 <sup>d</sup>	6 <sup>e</sup>	5,1	13,5	20	6,3	32	44
10	8	5,3	14,7	20	8,4	32	44
11	8 <sup>e</sup>	5,8	16	20	8,4	32	44
12 <sup>d</sup>	8	6,4	17,2	20	8,4	32	44
13	10	6,9	18,5	20	10,5	32	44
14 <sup>d</sup>	10	7,4	19,7	24	10,5	32	45
15 <sup>d</sup>	12	8,0	21,0	24	12,6	32	45
16	12 <sup>e</sup>	8,5	22,2	24	12,6	35	50
17 <sup>d</sup>	12	9,7	23,5	24	12,6	35	54
18	14	10,9	24,7	24,7	14,7	35	54
19 <sup>d</sup>	14	11,9	26	26	14,7	35	60

NOTE t<sub>min</sub> is interpolated for sizes not covered by ISO 4032 and ISO 4014.

a t<sub>min</sub> = m<sub>max</sub> + 0,1; where m<sub>max</sub> is the maximum height of the nut, according to ISO 4032.

b d<sub>3min</sub> = Dmax × 1,05

c The maximum thread diameter Dmax is the largest nominal thread diameter found in a current International Standards like, e.g. ISO 4014, ISO 4032, ISO 272.

d Nominal dimension not covered by ISO 272.

e Value determined in order to avoid reduction in hole clearance size.



Table 2 (continued)

s	Dmax <sup>c</sup> mm	t <sup>a</sup> min. mm	d <sub>1</sub> max. mm	d <sub>2</sub> max. mm	d <sub>3b</sub> <sup>b</sup> min.	l	
					Bolt clearance hole mm	max.	min.
						Type A (normal) mm	Type B (long) mm
21	16	12,9	28,5	28,8	16,8	38	60
22 <sup>d</sup>	16	13,9	29,7	29,7	16,8	38	60
24	16	14,9	32,5	32,5	16,8	38	65

NOTE  $t_{\min}$  is interpolated for sizes not covered by ISO 4032 and ISO 4014.

<sup>a</sup>  $t_{\min} = m_{\max} + 0,1$ ; where  $m_{\max}$  is the maximum height of the nut, according to ISO 4032.

<sup>b</sup>  $d_{3\min} = D_{\max} \times 1,05$

<sup>c</sup> The maximum thread diameter  $D_{\max}$  is the largest nominal thread diameter found in a current International Standards like, e.g. ISO 4014, ISO 4032, ISO 272.

<sup>d</sup> Nominal dimension not covered by ISO 272.

<sup>e</sup> Value determined in order to avoid reduction in hole clearance size.

Table 3 — Square drive of 12,5

s	Dmax <sup>c</sup> mm	t <sup>a</sup> min. mm	d <sub>1</sub> max. mm	d <sub>2</sub> max. mm	d <sub>3b</sub> <sup>b</sup> min.	l	
					Bolt clearance hole mm	max.	min.
						Type A (normal) mm	Type B (long) mm
8	6	4,8	14	24	6,3	40	75
9 <sup>d</sup>	6 <sup>e</sup>	5,1	14,1	24	5,8	40	75
10	8	5,3	15,5	24	8,4	40	75
11	8 <sup>e</sup>	5,8	16,7	24	8,4	40	75
12 <sup>d</sup>	8	6,4	18	24	8,4	40	75
13	10	6,9	19,2	24	10,5	40	75
14 <sup>d</sup>	10	7,4	20,5	24	10,5	40	75
15 <sup>d</sup>	12	8,0	21,7	24	12,6	40	75
16	12 <sup>e</sup>	8,5	23	25,5	12,6	40	75
17 <sup>d</sup>	12	9,7	24,2	25,5	12,6	40	75
18	14	10,9	25,5	25,5	14,7	42	75
19 <sup>d</sup>	14	11,9	26,7	26,7	14,7	42	75
21	16	12,9	29,2	29,2	16,8	44	75
22 <sup>d</sup>	16	13,9	30,5	30,5	16,8	44	75
24	16	14,9	33	33	16,8	46	75

NOTE  $t_{\min}$  is interpolated for sizes not covered by ISO 4032 and ISO 4014.

<sup>a</sup>  $t_{\min} = m_{\max} + 0,1$ ; where  $m_{\max}$  is the maximum height of the nut, according to ISO 4032.

<sup>b</sup>  $d_{3\min} = D_{\max} \times 1,05$

<sup>c</sup> The maximum thread diameter  $D_{\max}$  is the largest nominal thread diameter found in current International Standards like, e.g. ISO 4014, ISO 4032, ISO 272.

<sup>d</sup> Nominal dimension not covered by ISO 272.

<sup>e</sup> Value determined in order to avoid reduction in hole clearance size.

Table 3 (continued)

s	Dmax <sup>c</sup> mm	t <sup>a</sup> min. mm	d <sub>1</sub> max. mm	d <sub>2</sub> max. mm	d <sub>3</sub> <sup>b</sup> min. mm	l	
						max. Type A (normal) mm	min. Type B (long) mm
27	20	15,9	36,7	36,7	21,0	48	75
30	20	18,1	40,5	40,5	21,0	50	75
32 <sup>d</sup>	24	18,8	43	43	25,2	50	75
34	24 <sup>e</sup>	19,5	46,5	46,5	25,2	52	75

NOTE  $t_{\min}$  is interpolated for sizes not covered by ISO 4032 and ISO 4014.

a  $t_{\min} = m_{\max} + 0,1$ ; where  $m_{\max}$  is the maximum height of the nut, according to ISO 4032.

b  $d_{3\min} = D_{\max} \times 1,05$

c The maximum thread diameter  $D_{\max}$  is the largest nominal thread diameter found in current International Standards like, e.g. ISO 4014, ISO 4032, ISO 272.

d Nominal dimension not covered by ISO 272.

e Value determined in order to avoid reduction in hole clearance size.

Table 4 — Square drive of 20

s	Dmax <sup>c</sup> mm	t <sup>a</sup> min. mm	d <sub>1</sub> max. mm	d <sub>2</sub> max. mm	d <sub>3</sub> <sup>b</sup> min. mm	l	
						max. Type A (normal) mm	min. Type B (long) mm
21	16	12,9	32,1	40	16,8	55	85
22 <sup>d</sup>	16	13,9	33,3	40	16,8	55	85
24	16	14,9	35,8	40	16,8	55	85
27	20	15,9	39,6	40	21,0	60	85
30	20	18,1	43,3	43,3	21,0	60	85
32 <sup>d</sup>	24	18,8	45,8	45,8	25,2	60	85
34	24 <sup>e</sup>	19,5	48,3	48,3	25,2	65	85
36	24	21,6	50,8	50,8	25,2	67	85
41	27	23,9	57,1	57,1	28,4	70	85
46	30	25,7	63,3	63,3	31,5	83	100
50	33	28,8	68,3	68,3	34,7	89	100
55	36	31,1	74,6	74,6	37,8	95	100
60	39	33,5	84,5	84,5	41,0	100	100

NOTE  $t_{\min}$  is interpolated for sizes not covered by ISO 4032 and ISO 4014.

a  $t_{\min} = m_{\max} + 0,1$ ; where  $m_{\max}$  is the maximum height of the nut, according to ISO 4032.

b  $d_{3\min} = D_{\max} \times 1,05$

c The maximum thread diameter  $D_{\max}$  is the largest nominal thread diameter found in current International Standards like, e.g. ISO 4014, ISO 4032, ISO 272.

d Nominal dimension not covered by ISO 272.

e Value determined in order to avoid reduction in hole clearance size.

Table 5 — Square drive of 25

s	Dmax <sup>c</sup>	t <sup>a</sup> min.	d <sub>1</sub> max.	d <sub>2</sub> max.	d <sub>3</sub> <sup>b</sup> min.	l max
					Bolt clearance hole	Type A (normal)
	mm	mm	mm	mm	mm	mm
41	27	23,9	61	59,7	28,4	83
46	30	25,7	66,4	55	31,5	80
50	33	28,8	71,4	55	34,7	85
55	36	31,1	77,6	57	37,8	95
60	39	33,5	83,9	61	41,0	103
65	42	34,1	90,1	78	44,1	110
70	45	36,1	96,5	84	47,3	116

NOTE  $t_{\min}$  is interpolated for sizes not covered by ISO 4032 and ISO 4014.

<sup>a</sup>  $t_{\min} = m_{\max} + 0,1$ ; where  $m_{\max}$  is the maximum height of the nut, according to ISO 4032.

<sup>b</sup>  $d_{3\min} = D_{\max} \times 1,05$

<sup>c</sup> The maximum thread diameter  $D_{\max}$  is the largest nominal thread diameter found in current International Standards like, e.g. ISO 4014, ISO 4032, ISO 272.

## 5 Technical specifications

The technical specifications shall be in accordance with ISO 1711-1.

## 6 Designation

A hand-operated square drive socket in accordance with this part of ISO 2725 shall be designated by

- “Hex socket” or “Bi-hex socket”, depending on its form,
- reference to this part of ISO 2725 (i.e. ISO 2725-1),
- square drive dimensions, in millimetre,
- width across flats, in millimetre, and
- type.

EXAMPLE A double hexagon hand-operated square drive socket with 12,5 mm square size and width across flats  $s = 10$  mm, normal Type A, is designated as follows:

Bi-hex socket ISO 2725-1 - 12,5 × 10 - A

## 7 Marking

The hand-operated square drive socket shall be marked, permanently and legibly, with at least the following information:

- the name or trademark of the manufacturer or supplier;
- the width across flats.

## Bibliography

- [1] ISO 272, *Fasteners — Hexagon products — Widths across flats*
- [2] ISO 1703, *Assembly tools for screws and nuts — Designation and nomenclature*
- [3] ISO 2725-2, *Assembly tools for screws and nuts — Square drive sockets — Part 2: Machine-operated sockets (“impact”)*

This page is intentionally blank.

This page is intentionally blank.

This page is intentionally blank.

