Diesel engines — Clamp-mounted fuel injectors, types 7 and 28

Moteurs à allumage par compression — Porte-injecteurs de combustible complets à fixation par patte, types 7 et 28





COPYRIGHT PROTECTED DOCUMENT

© ISO 2016, Published in Switzerland

All rights reserved. Unless otherwise specified, no part of this publication may be reproduced or utilized otherwise in any form or by any means, electronic or mechanical, including photocopying, or posting on the internet or an intranet, without prior written permission. Permission can be requested from either ISO at the address below or ISO's member body in the country of the requester.

ISO copyright office
Ch. de Blandonnet 8 • CP 401
CH-1214 Vernier, Geneva, Switzerland
Tel. +41 22 749 01 11
Fax +41 22 749 09 47
copyright@iso.org
www.iso.org

Contents

	Page
Foreword	iv
1 Scope	1
2 Normative references	1
3 Terms and definitions	1
4 Dimensions and tolerances	1
4.1 Injectors, types 7 and 28	1
4.2 Clamp location	3
4.3 Preferred length, <i>L</i>	4
5 Other specifications	4
Bibliography	5

Foreword

ISO (the International Organization for Standardization) is a worldwide federation of national standards bodies (ISO member bodies). The work of preparing International Standards is normally carried out through ISO technical committees. Each member body interested in a subject for which a technical committee has been established has the right to be represented on that committee. International organizations, governmental and non-governmental, in liaison with ISO, also take part in the work. ISO collaborates closely with the International Electrotechnical Commission (IEC) on all matters of electrotechnical standardization.

The procedures used to develop this document and those intended for its further maintenance are described in the ISO/IEC Directives, Part 1. In particular the different approval criteria needed for the different types of ISO documents should be noted. This document was drafted in accordance with the editorial rules of the ISO/IEC Directives, Part 2 (see www.iso.org/directives).

Attention is drawn to the possibility that some of the elements of this document may be the subject of patent rights. ISO shall not be held responsible for identifying any or all such patent rights. Details of any patent rights identified during the development of the document will be in the Introduction and/or on the ISO list of patent declarations received (see www.iso.org/patents).

Any trade name used in this document is information given for the convenience of users and does not constitute an endorsement.

For an explanation on the meaning of ISO specific terms and expressions related to conformity assessment, as well as information about ISO's adherence to the World Trade Organization (WTO) principles in the Technical Barriers to Trade (TBT) see the following URL: www.iso.org/iso/foreword.html.

The committee responsible for this document is ISO/TC 22, *Road vehicles*, Subcommittee SC 34, *Propulsion, powertrain, and powertrain fluids*.

This fourth edition cancels and replaces the third edition (ISO 2698:2013), which has been technically revised.

Diesel engines — Clamp-mounted fuel injectors, types 7 and 28

1 Scope

This document specifies dimensions necessary for the mounting of fuel injectors in diesel (compression-ignition) engines.

The location of the fuel inlet and leak-off connections, and the dimensions of the clamp are not defined since they vary according to the particular application.

This document applies to clamp-mounted injectors of types 7 and 28 made of an integral nozzle and nozzle holder design with a 9,5 mm (nominal) injector shank diameter.

2 Normative references

The following documents are referred to in the text in such a way that some or all of their content constitutes requirements of this document. For dated references, only the edition cited applies. For undated references, the latest edition of the referenced document (including any amendments) applies.

ISO 4288, *Geometrical Product Specifications (GPS) — Surface texture: Profile method — Rules and procedures for the assessment of surface texture*.

3 Terms and definitions

No terms and definitions are listed in this document.

ISO and IEC maintain terminological databases for use in standardization at the following addresses:

- IEC Electropedia: available at <http://www.electropedia.org/>
- ISO Online browsing platform: available at <http://www.iso.org/obp>

4 Dimensions and tolerances

4.1 Injectors, types 7 and 28

Dimensions and tolerances of injectors of types 7 and 28 are given in [Figure 1](#) and [Figure 2](#), respectively.

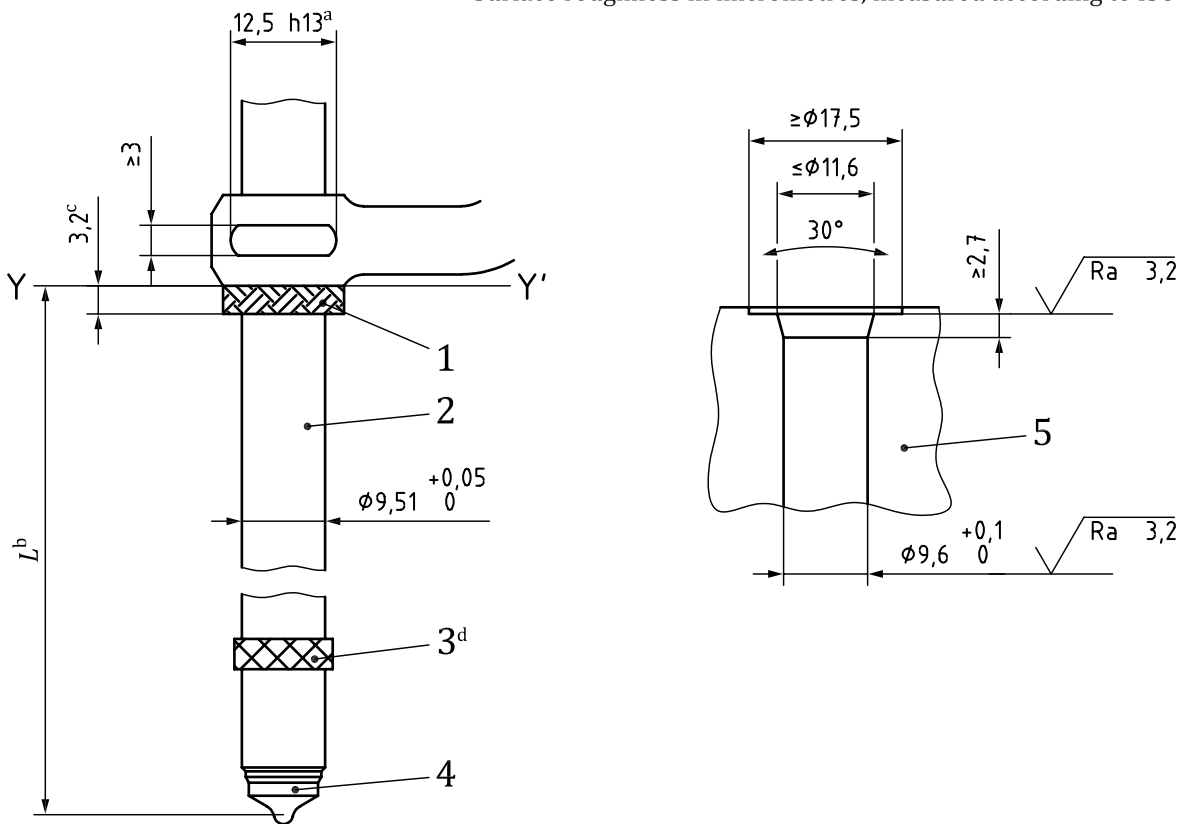

Key

- 1 sealing washer
- 2 nozzle holder
- 3 seal
- 4 nozzle
- 5 engine
- a These flats are optional.
- b See 4.3.
- c With commercial tolerances (before compression).
- d The outer diameter of the seal shall be chosen such that it provides appropriate sealing with the injector bore.

Figure 1 — Clamp-mounted injector, type 7

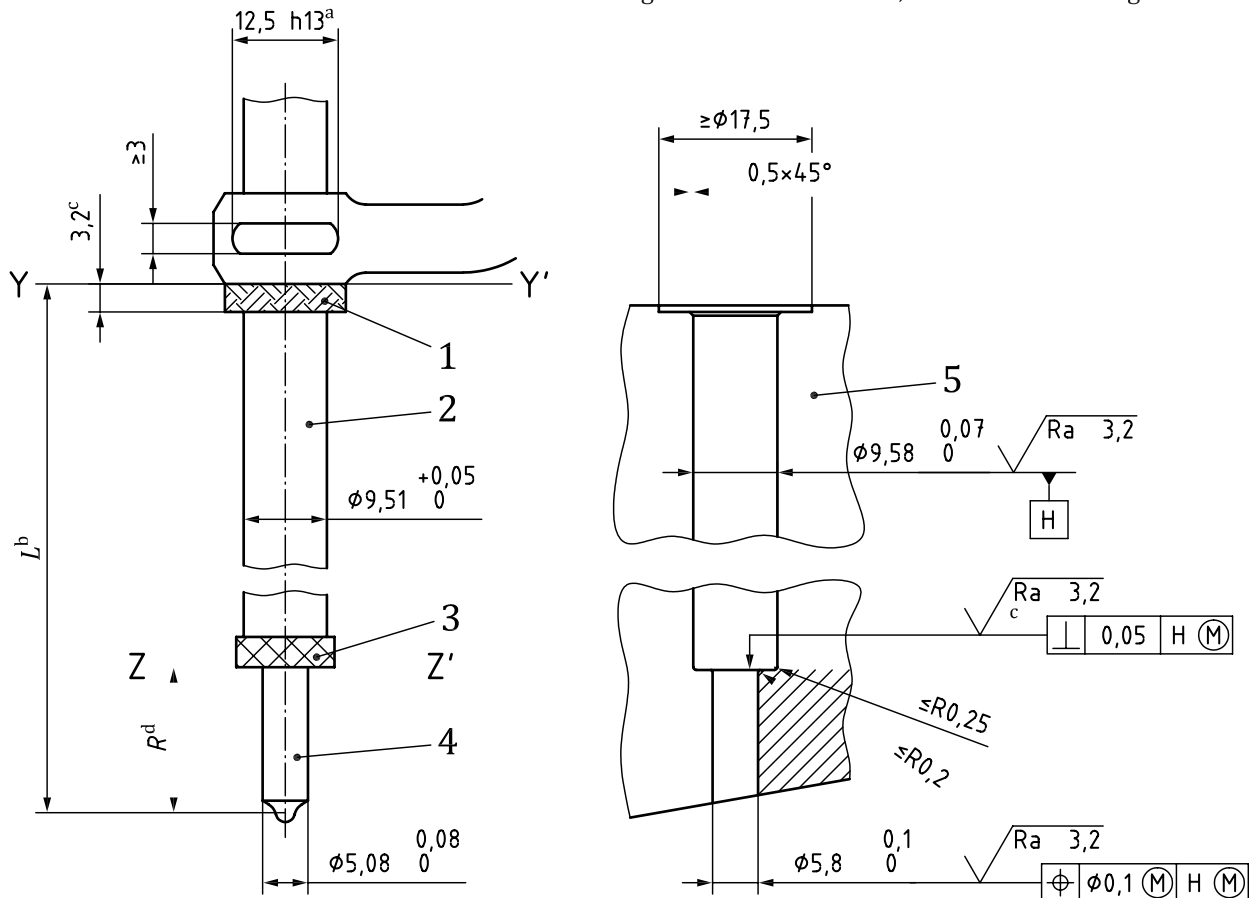

Key

- 1 dust/water seal
- 2 nozzle holder
- 3 seal
- 4 nozzle
- 5 engine
- a These flats are optional.
- b See 4.3.
- c With commercial tolerances (before compression).
- d This dimension determines the distance between the reference plane ZZ' and the point of intersection of the injection holes axes with the injector axis, when the sealing washer is compressed; it varies with nozzle sac design.

Figure 2 — Clamp-mounted injector, type 28

4.2 Clamp location

Dimensions and tolerances for the clamp location as related to the injector are given in [Figure 3](#).

Dimension, X, and thread diameter, A, for the clamp fastener, as given in [Table 1](#), are preferred values; they can vary with application, i.e. depending on cylinder head design.

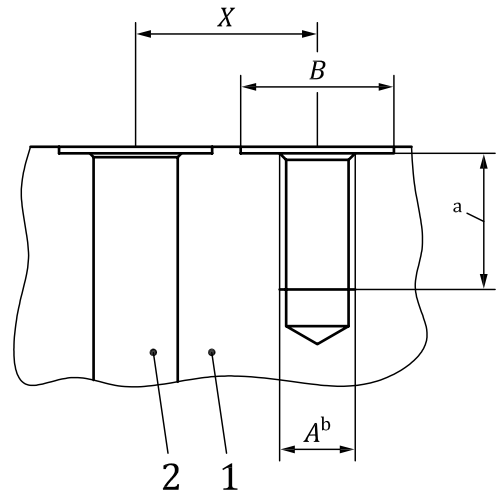

- Key**
- 1 engine
 - 2 injector bore
 - a Minimum length as required.
 - b Clamp fastener thread.

Figure 3 — Clamp location for injectors, types 7 and 28

Table 1 — Injector type X, A and B

Dimensions in millimetres

Injector type	X ±0,3	A ^a nom.	ØB min.
7 and 28	18,4	M8 × 1,25	15,8
	25	M10 × 1,5	16,9

^a For fasteners of property class 9,8.

4.3 Preferred length, L

The length, *L*, determines the distance between the reference plane YY' and the point of intersection of the injection holes axes with the injector axis (see [Figure 1](#) and [Figure 2](#)); it varies with the application, i.e. depending on the cylinder head design.

The dimensions and tolerances for the preferred length, *L*, are given in [Table 2](#).

Table 2 — Injector type L

Dimensions in millimetres

Injector type	L ±0,3
7 and 28	81,4

5 Other specifications

Dimensions and requirements not given in this document are left to the discretion of the manufacturer.

Bibliography

- [1] ISO 898-1, *Mechanical properties of fasteners made of carbon steel and alloy steel — Part 1: Bolts, screws and studs with specified property classes — Coarse thread and fine pitch thread*
- [2] ISO 2692, *Geometrical product specifications (GPS) — Geometrical tolerancing — Maximum material requirement (MMR), least material requirement (LMR) and reciprocity requirement (RPR)*
- [3] ISO 7876-2, *Fuel injection equipment — Vocabulary — Part 2: Fuel injectors*

