

INTERNATIONAL STANDARD**2647**

H-37-03

INTERNATIONAL ORGANIZATION FOR STANDARDIZATION • МЕЖДУНАРОДНАЯ ОРГАНИЗАЦИЯ ПО СТАНДАРТИЗАЦИИ • ORGANISATION INTERNATIONALE DE NORMALISATION

**Wool — Determination of percentage of medullated fibres by
the projection microscope**

First edition — 1973-04-01

UDC 677.31/.33 : 531.717 : 535.822

Ref. No. ISO 2647-1973 (E)

Descriptors : fibres, animal fibres, wool fibres, tests, determination, medullated fibres.

Price based on 2 pages

FOREWORD

ISO (the International Organization for Standardization) is a worldwide federation of national standards institutes (ISO Member Bodies). The work of developing International Standards is carried out through ISO Technical Committees. Every Member Body interested in a subject for which a Technical Committee has been set up has the right to be represented on that Committee. International organizations, governmental and non-governmental, in liaison with ISO, also take part in the work.

Draft International Standards adopted by the Technical Committees are circulated to the Member Bodies for approval before their acceptance as International Standards by the ISO Council.

International Standard ISO 2647 was drawn up by Technical Committee ISO/TC 38, *Textiles*, and circulated to the Member Bodies in April 1972.

It has been approved by the Member Bodies of the following countries :

Belgium	India	South Africa, Rep. of
Brazil	Iran	Spain
Canada	Ireland	Sweden
Chile	Israel	Switzerland
Czechoslovakia	Japan	Thailand
Egypt, Arab Rep. of	New Zealand	Turkey
Finland	Pakistan	United Kingdom
France	Poland	U.S.A.
Germany	Portugal	U.R.S.S.
Hungary	Romania	

No Member Body expressed disapproval of the document.

This International Standard is based on the IWTO Test Method 12-64, drawn up by the International Wool Textile Organization (IWTO).

Wool — Determination of percentage of medullated fibres by the projection microscope

0 INTRODUCTION

The method specified in this International Standard utilizes the same apparatus and technique as that described in ISO/R 137.

Since the method of preparation and measurement gives a length-biassed sample, the result given by this method is an estimate of the length of medullated fibres as a percentage of the total length of all fibres. It cannot be used to estimate the volume of medullation or the fibre density.

1 SCOPE AND FIELD OF APPLICATION

This International Standard specifies a method of test for determining the percentage of medullated wool fibres by means of the projection microscope.

The method is applicable to woollen and worsted products, at all stages, from raw materials to yarn.

2 REFERENCES

ISO/R 137, *Determination of wool fibre diameter — Projection microscope method.*

ISO 139, *Textiles — Standard atmospheres for conditioning and testing.*

3 PRINCIPLE

Magnified images of the profiles of short pieces of fibre are projected on a screen, and the number that are medullated is counted and expressed as a percentage of the total.

4 APPARATUS

Projection microscope, microtome, mounting media, etc. as specified in ISO/R 137.

5 ATMOSPHERE FOR CONDITIONING AND TESTING

5.1 A standard atmosphere is not necessary if only medullation is measured.

5.2 If fibre diameter is also being measured, the sample must be conditioned and the slide prepared in one of the standard atmospheres for testing defined in ISO 139.

6 PREPARATION OF TEST SPECIMENS

Sample the wool, prepare the specimens and mount them as directed in ISO/R 137.

7 PROCEDURE

7.1 The test may be carried out conveniently at the same time as diameter measurement.

7.2 The procedure is exactly the same as that described in ISO/R 137, except that when the width of the fibre image is read off, it is also examined for medullation at the point of measurement.

7.3 Fibre images that show any evidence of medulla at the point where the longitudinal line of the scale crosses it are recorded differently from those showing no medulla. This may be done, for example, by recording medullated fibres with a cross (x) and non-medullated fibres with a dot (.).

7.4 Images showing a medulla which does not cross the scale at the point of measurement are recorded as non-medullated.

Diagrams showing the appearance of fibre images during measurement are provided in Figures 1 to 3.

ISO 2647-1973 (E)

8 CALCULATION AND EXPRESSION OF RESULTS

Calculate the number of medullated fibre images as a percentage of the total number of images examined.

The standard error SE of the percentage of medullated fibres is given by the formula :

$$SE = \sqrt{\frac{m}{n} (100 - m)}$$

where

m is the percentage of medullated fibres;

n is the total number of fibres examined.

9 TEST REPORT

The test report shall include the following information

- a) reference to this International Standard;
- b) the total number of fibres examined;
- c) the results obtained;
- d) all operating conditions not specified in this International Standard as well as any incidents that may have influenced the results.

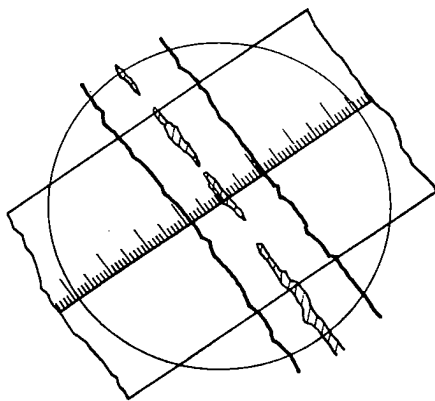

FIGURE 1 – Narrow medulla

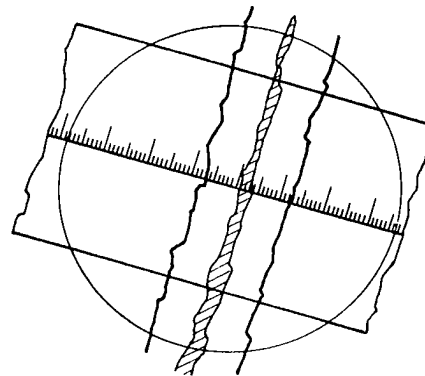

FIGURE 2 – Continuous medulla

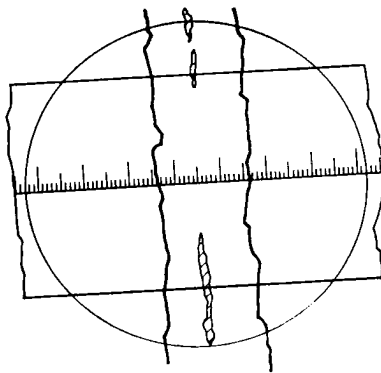

FIGURE 3 – No medulla

Appearance of medulla at place of measurement