

---

International Standard



2586

---

INTERNATIONAL ORGANIZATION FOR STANDARDIZATION • МЕЖДУНАРОДНАЯ ОРГАНИЗАЦИЯ ПО СТАНДАРТИЗАЦИИ • ORGANISATION INTERNATIONALE DE NORMALISATION

---

**Shell end mills with plain bore and tenon drive —  
Metric series**

*Fraises cylindriques 2 tailles, à alésage lisse, à entraînement par tenons — Série métrique*

**Second edition — 1985-09-01**

---

**UDC 621.914.2**

**Ref. No. ISO 2586-1985 (E)**

**Descriptors :** tools, cutting tools, milling cutters, end mills, dimensions.

## Foreword

ISO (the International Organization for Standardization) is a worldwide federation of national standards bodies (ISO member bodies). The work of preparing International Standards is normally carried out through ISO technical committees. Each member body interested in a subject for which a technical committee has been established has the right to be represented on that committee. International organizations, governmental and non-governmental, in liaison with ISO, also take part in the work.

Draft International Standards adopted by the technical committees are circulated to the member bodies for approval before their acceptance as International Standards by the ISO Council. They are approved in accordance with ISO procedures requiring at least 75 % approval by the member bodies voting.

International Standard ISO 2586 was prepared by Technical Committee ISO/TC 29, *Small tools*.

ISO 2586 was first published in 1973. This second edition cancels and replaces the first edition: tolerances on *L* and *l* given in the table have been altered.

# Shell end mills with plain bore and tenon drive — Metric series

## 1 Scope and field of application

This International Standard specifies the dimensions of shell end mills with plain bore and tenon drive intended for fitting to the ends of cutter arbors.

It applies to metric series mills. It relates only to solid cutters, in steel.

The dimensional features of this type of cutter either with solid steel inserted blades or with brazed tips or with indexable inserts will form the subject of further International Standards.

The range of outside diameters of these cutters is taken from ISO 523.

## 2 References

ISO 240, *Milling cutters — Interchangeability dimensions for cutter arbors or cutter mandrels — Metric series and inch series.*

ISO 523, *Milling cutters — Recommended range of outside diameters.*

ISO 2780, *Milling cutters with tenon drive — Interchangeability dimensions with cutter arbors — Metric series.*<sup>1)</sup>

1) At present at the stage of draft. (Revision of ISO 2780-1973.)

3 Dimensions

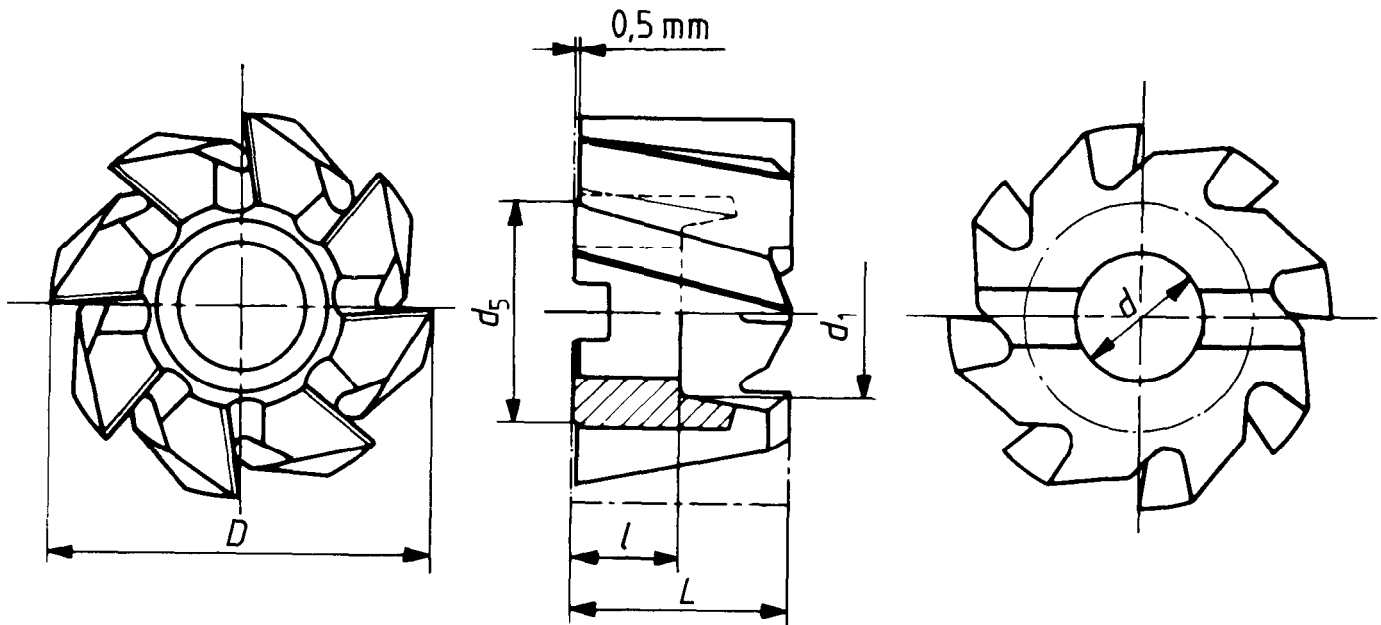

Dimensions and tolerances in millimetres

$D$ $i_s 16$	$d$ H7	$L$ k16	$l$ $+1$ 0	$d_1$ min.	$d_5^{1)}$ min.
40	16	32	18	23	33
50	22	36	20	30	41
63	27	40	22	38	49
80	27	45	22	38	49
100	32	50	25	45	59
125	40	56	28	56	71
160	50	63	31	67	91

The tenon seatings shall be in accordance with the metric series of ISO 240.

These cutters are with helicoidal teeth angled to the right or left.

1) A backing-off length of 0,5 mm on the rear face is optional.

