

INTERNATIONAL STANDARD

H-56-30

2556

INTERNATIONAL ORGANIZATION FOR STANDARDIZATION • МЕЖДУНАРОДНАЯ ОРГАНИЗАЦИЯ ПО СТАНДАРТИЗАЦИИ • ORGANISATION INTERNATIONALE DE NORMALISATION

**Plastics — Determination of the gas transmission rate of films and thin sheets under atmospheric pressure —
Manometric method***Matières plastiques — Détermination du coefficient de transmission d'un gaz par les feuilles et plaques minces, sous pression atmosphérique — Méthode manométrique***First edition — 1974-06-01****UDC 678.5/.8-416 : 620.165.29****Ref. No. ISO 2556-1974 (E)****Descriptors : plastics, sheets, thin films, diffusion, gas, determination, pressure test.**

Price based on 6 pages

FOREWORD

ISO (the International Organization for Standardization) is a worldwide federation of national standards institutes (ISO Member Bodies). The work of developing International Standards is carried out through ISO Technical Committees. Every Member Body interested in a subject for which a Technical Committee has been set up has the right to be represented on that Committee. International organizations, governmental and non-governmental, in liaison with ISO, also take part in the work.

Draft International Standards adopted by the Technical Committees are circulated to the Member Bodies for approval before their acceptance as International Standards by the ISO Council.

International Standard ISO 2556 was drawn up by Technical Committee ISO/TC 61, *Plastics*, and circulated to the Member Bodies in February 1972.

It has been approved by the Member Bodies of the following countries :

Australia	India	Spain
Austria	Ireland	Sweden
Belgium	Israel	Switzerland
Brazil	Japan	Thailand
Canada	New Zealand	Turkey
Czechoslovakia	Poland	United Kingdom
Egypt, Arab Rep. of	Portugal	U.S.A.
France	Romania	U.S.S.R.
Germany	South Africa, Rep. of	

The Member Body of the following country expressed disapproval of the document on technical grounds :

Netherlands

© International Organization for Standardization, 1974 •

Printed in Switzerland

Plastics — Determination of the gas transmission rate of films and thin sheets under atmospheric pressure — Manometric method

1 SCOPE AND FIELD OF APPLICATION

This International Standard specifies a method for the determination of the gas transmission rate of plastics films and thin sheets.

The limits of the values which can be measured are from 1 to 20 000 cm³/m².d.atm.

The method can be used for measurements made either with air or with other test gases.

2 REFERENCE

ISO/R 291, *Plastics — Standard atmospheres for conditioning and testing.*

3 DEFINITION

gas transmission rate: The volume of gas which, under steady conditions, crosses unit area of the sample in unit time under unit pressure difference and at constant temperature. This volume is expressed at standard temperature and pressure.

The rate depends on the thickness of the test specimen, and the reliability of the results depends on the evenness of the specimen thickness.

The rate is usually expressed in cubic centimetres (at 0 °C under standard atmospheric pressure per square metre per 24 h under a pressure difference of 1 atm (cm³/m².d.atm).

NOTES

- The SI unit of gas transmission rate is fm/Pa.s
[1 fm (femtometre) = 10⁻¹⁵ m]
1 cm³/m².d.atm = 0,114 3 fm/Pa.s and
1 fm/Pa.s = 8,752 cm³/m².d.atm.

- The standard atmospheric pressure corresponds to the pressure of a mercury column 760 mm high: either 1 013 mbar or 101,3 kPa.

4 PRINCIPLE

The plastic test specimen separates two chambers numbered 1 and 2. Chamber 1 contains the test gas at atmospheric pressure. Chamber 2, of known initial volume, has the air pumped out until the pressure is practically zero, then is hermetically sealed.

The quantity of gas which passes through the specimen from chamber 1 to chamber 2 is determined as a function of time by measuring the increases of pressure occurring in chamber 2 by means of a manometer.

The transmission rate is calculated from the values obtained, excluding the initial period during which the rate of passage of gas increases with time.

5 APPARATUS AND MATERIALS

The apparatus which comprises the parts described in 5.1 to 5.4, and of which suitable examples are shown in figures 1 and 2, must be placed in an enclosure with the temperature constant to within ± 2 °C during the test.

5.1 Metal cell consisting of two detachable parts, as follows:

- an upper part forming the cylindrical chamber 1 to contain the test gas, provided with tubes for the entry and exit of the gas employed;
 - a lower part forming a plane and polished "test plate" of diameter 100 to 120 mm and having at its centre either
 - a cavity of about 20 mm diameter containing a perforated disc and below this a small empty space so that the total depth of the cavity is 12 to 15 mm (see figure 1). In this type of apparatus a filter paper must be interposed between the specimen and the test plate. The diameter of this filter paper must be near, but not greater than, the internal diameter of the gasket;
- or,
- a cavity about 60 mm diameter and a few millimetres deep, filled with a sintered disc of glass or of bronze (see figure 2).

The filter paper indicated in a) or the sintered disc indicated in b) are to support the test specimen while at the same time allowing the passage of gas.

In case b) the upper part of the sintered disc must be level with the test plate so that the specimen rests flat over its whole surface.

The closed space below the test specimen forms chamber 2, and is attached to a capillary tube (5.2) forming the manometer and to a vacuum pump (5.5).

ISO 2556-1974 (E)

The two parts of the cell are clamped together by means of an effective clamping device, a circular gasket of rubber being used to isolate the cell completely from the external atmosphere and to prevent the passage of gas from chamber 1 to chamber 2 other than through the test specimen.

NOTE — It is recommended that a check of the airtightness of the apparatus should be made by carrying out a blank test in accordance with the procedure of clause 7 but with the test specimen replaced by metal foil.

The level of the mercury in the capillary must remain practically unchanged during a period of the same order as that needed for the proposed measurements.

5.2 Calibrated capillary tube about 1,5 to 2 mm internal diameter and 200 to 400 mm in length, connected to the base of the metal cell. A scale graduated to 0,5 mm indicates the mercury level in the capillary tube.

5.3 U-tube about 5 mm diameter, connected to the bottom of the capillary tube as shown in figures 1 and 2.

One arm of the tube is closed. The other arm is joined to a vacuum stopcock (which can be connected to a vacuum pump) and to a mercury reservoir (5.4) into which the mercury can be poured by overflowing.

5.4 Mercury reservoir fixed to the arm of the U-tube connected to the vacuum stopcock. This fixing can be done by method 1) or 2) described below.

1) Fixing directly to the U-tube arm (see figure 1).

This type of apparatus can be arranged to function either with or without overflowing of mercury during the test.

a) In the case of apparatus with overflowing, the U-tube is filled with mercury up to the overflowing level which also corresponds to the scale zero (as shown in figure 1).

During the test the mercury level is maintained constant by overflowing. Nevertheless the regulation of the level is not altogether perfect since the overflowing occurs jerkily.

It may therefore be preferable to use the apparatus in the manner described in b).

b) In the case of apparatus without overflowing, the U-tube is only filled to a point appreciably below the overflowing level, so that the whole test is carried out without overflowing. In this case the scale zero is below the overflowing level and in the calculation a correction is essential (see 8.2).

2) The reservoir may be fixed to a greatly enlarged portion of this arm of the tube (about 20 mm diameter) and there is no overflowing during the test (see figure 2).

5.5 Vacuum pump giving a pressure at the most equal to 13 Pa (0,13 mbar or 0,1 mmHg) in the lower chamber, and a gauge to measure this pressure with an accuracy of 6 Pa (0,06 bar or 0,05 mmHg) or better.

5.6 Mercury barometer.

5.7 Thermometer which can be read to 0,5 °C.

5.8 Mercury.

5.9 Test gases and drying column if required.

6 TEST SPECIMENS

The specimens shall be representative of the batch of sheet or film for test and free from marks or visible defects (creases, thin spots, porosity, holes, etc.).

They shall be in the form of discs with a diameter, depending on the apparatus used, large enough to overlap the joint between the two portions of the metal cell. This diameter is usually about 80 mm.

At least three specimens must be tested.

Specimens of hygroscopic materials shall be conditioned in the selected atmosphere, preferably one of the atmospheres defined in ISO/R 291.

The duration of conditioning depends on the material and shall be specified.

7 PROCEDURE

Carry out the test within the enclosure specified in clause 5 controlled at 23 ± 2 °C, or if required at one of the other temperatures given in ISO/R 291.

7.1 Introduce the mercury into the reservoir (5.4). The quantity shall be such that, after pouring out the mercury into the capillary tube and the two arms of the U-tube, the level of the mercury is at the zero graduation of the capillary (and a portion overflows back into the reservoir when an apparatus used with overflowing (5.4, 1)a) is employed).

7.2 If an apparatus according to 5.1, 2)a) is used, place a circle of filter paper of sufficient size on the test plate.

7.3 Smear a very thin film of vacuum grease in the region of the joint, taking care not to put it on the filter paper.

7.4 Mount the specimen, then the rubber gasket, and finally the upper part of the metal cell.

7.5 Clamp the two parts of the cell together so that the joint is perfectly airtight.

7.6 Join the gas entry tube through the drying column to the reservoir of compressed gas. Pass the gas slowly into chamber 1 throughout the test.

NOTE — By agreement, the drying column may be omitted and gas with a known percentage humidity employed. This point must then be included in the test report.

7.7 Connect the stopcock to the vacuum pump and operate the pump until the pressure in chamber 2 is less than 27 Pa (0,2 mmHg), checked with the gauge described in 5.5.

7.8 Close the stopcock, then tilt the apparatus to cause the mercury to run into the capillary and the arms of the U-tube.

Fix the apparatus upright so that the capillary tube is vertical.

Check that the mercury level in the capillary is at the zero of the scale. If not, adjust the quantity of mercury by tilting the apparatus.

If the apparatus is used with overflowing of mercury (5.4, 1a)), a part of the mercury must be returned to the reservoir.

In all cases the mercury must be at the same level in the three tubes (zero level of the scale).

7.9 Note the value h of the mercury level in the capillary as a function of time t , remembering that this value h is measured from the mercury level at the start of the test.

NOTE — During the test, the difference between the mercury levels in the two arms of the U-tube must always be small. If the mercury level in the closed arm is observed to rise above the level in the other arm, this indicates that there is a leak at the stopcock.

Continue the test until the variation of h for equal intervals of time remains constant or decreases very gradually during five or six successive intervals of time.

The accuracy of the readings of h and t and the spacing of the time intervals depends on the apparatus and on the transmission rate to be measured. The accuracy of reading must be such that the results of measurements of difference in h and difference in t finally used in the calculation (see 8.3) are accurate to 1 to 2 % or better.

NOTE — The measurements of mercury level must be made at least to the nearest 0,25 mm. However, it is recommended that, for transmission rates below $100 \text{ cm}^3/\text{m}^2 \cdot \text{d} \cdot \text{atm}$, these measurements be made to the nearest 0,1 mm; a good magnifying glass or a cathetometer is therefore necessary.

The measurements of time must be made to the nearest minute if the rates are less than $100 \text{ cm}^3/\text{m}^2 \cdot \text{d} \cdot \text{atm}$, and to the nearest 5 s if the rates are greater.

7.10 At the end of the measurements, return the mercury to the reservoir, allow air to enter the apparatus, turn off the gas supply, take out the test specimen and clean the test plate.

7.11 At the end of the test, measure and record the atmospheric pressure H in centimetres of mercury, by means of the barometer (5.6).

NOTE — If the sample has a very low transmission rate and if the apparatus allows, it is recommended that the volume of chamber 2 be reduced by a metallic packing block placed in the empty cavity. This block, which has the effect of increasing the rate of displacement of the mercury in the capillary, must nevertheless allow sufficient duration of measurement to reach the constant regime before the end of the test.

8 EXPRESSION OF RESULTS

8.1 Initial volume of chamber 2

This value (V), is a constant for a given apparatus. It is the volume, in cubic centimetres, of chamber 2 from the lower face of the test specimen when it is pressed onto the support to the zero graduation of the capillary; it is reduced by the volume of the packing block when used.

This volume comprises :

- The volume of the voids in the filter paper and the perforated disc, or in the sintered disc of glass or bronze.

The calculation of this volume can be made by determining the total volume and subtracting from it the volume of the solid calculated from the mass and density of the porous product (density of cellulose fibre = $1,45 \text{ g/cm}^3$).

- The volume of the empty space in the lower plate (if present), less the volume of any packing block used.
- The volume of the capillary as far as the zero graduation.

8.2 Calculation of correction coefficient

If the test has been made with overflowing (5.4, 1a)), the correction coefficient c is equal to unity and there is no correction to make.

In the other case, calculate the correction coefficient c from the formula

$$c = 1 + \frac{a}{u}$$

where

a is the internal cross-section of the capillary tube;

u is the total internal cross-section of the U-tube (both sides) at the level of the mercury, a and u being expressed in the same unit.

NOTE — This correction is made necessary by the fact that when there is no overflowing in the course of the test the level of the mercury in the U-tube (reference level for the pressure) rises slightly.

ISO 2556-1974 (E)

8.3 Determination of transmission rate

Prepare a graph by plotting the values of h in centimetres as a function of the time t in hours, tenths, etc.

Disregard the initial part of the curve during which the slope dh/dt increases with time and choose a point on the curve at a value t such that the slope of the curve is practically constant (straight line) or diminishing very slightly.

Calculate the value of dh/dt at this point and note the corresponding value of h in centimetres.

Calculate the transmission rate G , in cubic centimetres per square metre per 24 h under a pressure difference of 1 atm, from the formula

$$G = 24 \times \frac{T_0}{T} \times \frac{1}{P_0} \times \frac{10^4}{A} \times \frac{V + 2ah}{H - ch} \times c \frac{dh}{dt} \dots (1)$$

where

$$T_0 = 273 \text{ K};$$

T is the temperature of test, in kelvins;

P_0 is the normal atmospheric pressure, in atmospheres; therefore $P_0 = 1$;

A is the area of the working surface of the test specimen, defined by the gasket, in square centimetres;

V is the initial volume of chamber 2, in cubic centimetres (see 8.1);

a is the internal cross-section of the capillary tube, in square centimetres;

h is the height of the mercury in the capillary read at time t , in relation to the level at the start of the test, in centimetres;

H is the height of the mercury column corresponding to the atmospheric pressure at the time of the test (barometric height), in centimetres;

c is the correction coefficient, dependent on the apparatus (see 8.2);

$\frac{dh}{dt}$ is the slope of the curve at the point t , in centimetres per hour.

Calculate the transmission rate, retaining only the number of significant figures corresponding to the accuracy of the measurements, either two or three figures at the most.

NOTE — The formula (1) implies that all the factors are expressed in the indicated units.

The basic formula from which these calculations are made is as follows :

$$G = 24 \times \frac{T_0}{T} \times \frac{1}{P_0} \times \frac{10^4}{A} \times \frac{V + 2ah}{P - p} \times \frac{dp}{dt} \dots (2)$$

where

P is the atmospheric pressure at the time of test;

p is the pressure in chamber 2 at time t ;

$\frac{dp}{dt}$ is the variation of pressure at time t .

P , p (and dp) are expressed in the same units.

To pass from formula (2) to the practical formula (1), let

$$P = kH \dots (3)$$

and

$$p = kch \dots (4)$$

k being a constant dependent on the units expressing P and p in relation to those expressing H and h . This constant has the dimensions of the quotient pressure/length, i.e. $MT^{-2}L^{-2}$, and is the pressure exerted by unit height of a mercury column. When P and p are measured in centimetres of mercury, and H and h in centimetres, then $k = 1$.

By replacing in formula (2) successively p (and dp) then P by the values of formulas (4) and (3), the following formulas are obtained :

$$G = 24 \times \frac{T_0}{T} \times \frac{1}{P_0} \times \frac{10^4}{A} \times \frac{V + 2ah}{P - kch} \times kc \frac{dh}{dt} \dots (5)$$

$$G = 24 \times \frac{T_0}{T} \times \frac{1}{P_0} \times \frac{10^4}{A} \times \frac{V + 2ah}{H - ch} \times c \frac{dh}{dt} \dots (1)$$

9 TEST REPORT

The test report shall include the following particulars :

- description of the sample and its mean thickness and, if carried out, the conditioning;
- number of test specimens;
- details of the apparatus used;
- the test gas used, and its relative humidity if applicable;
- the temperature of test;
- the values of transmission rate calculated for each test specimen and their mean value.

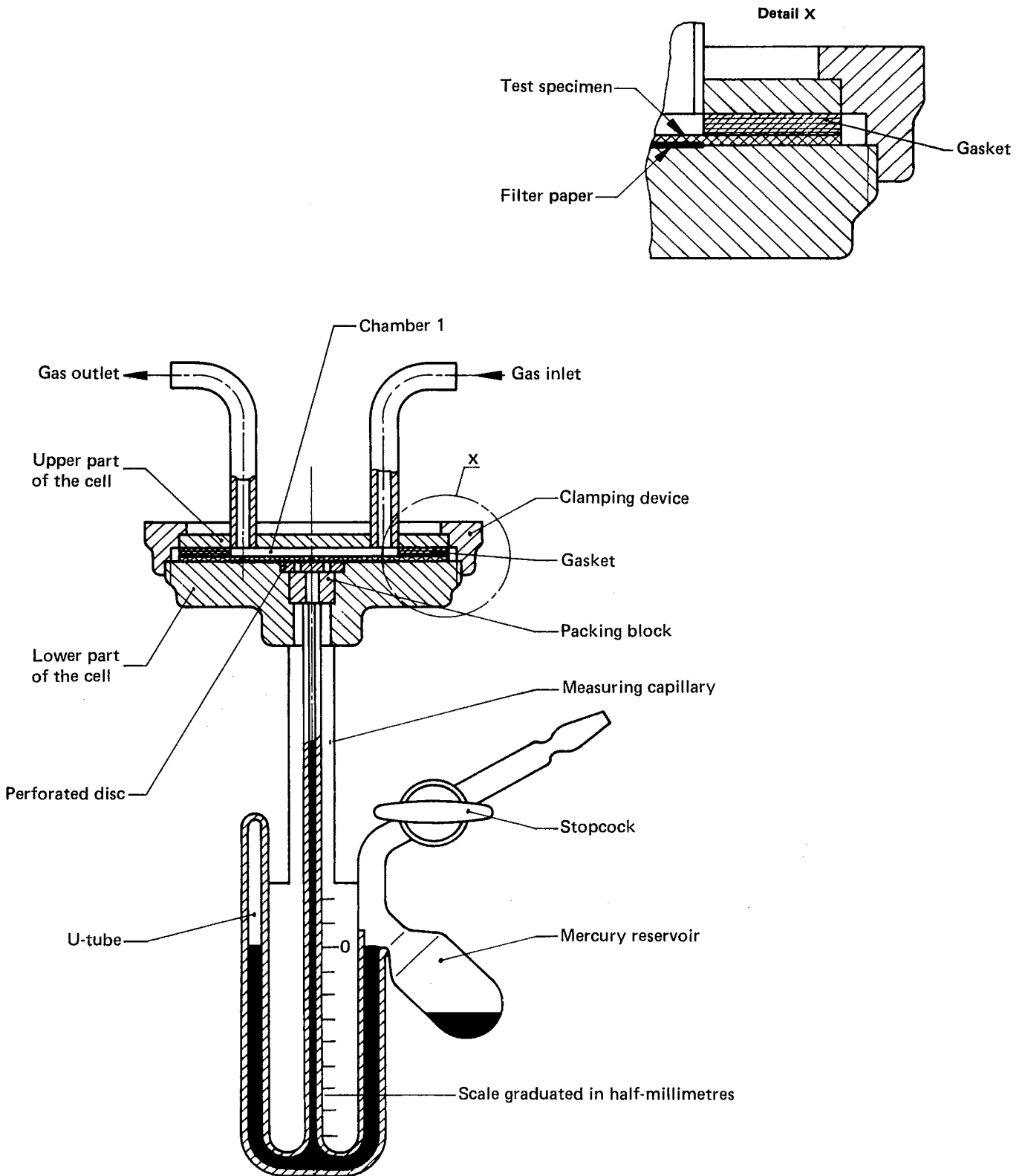

FIGURE 1 — Example of apparatus with overflowing (5.4, 1a)

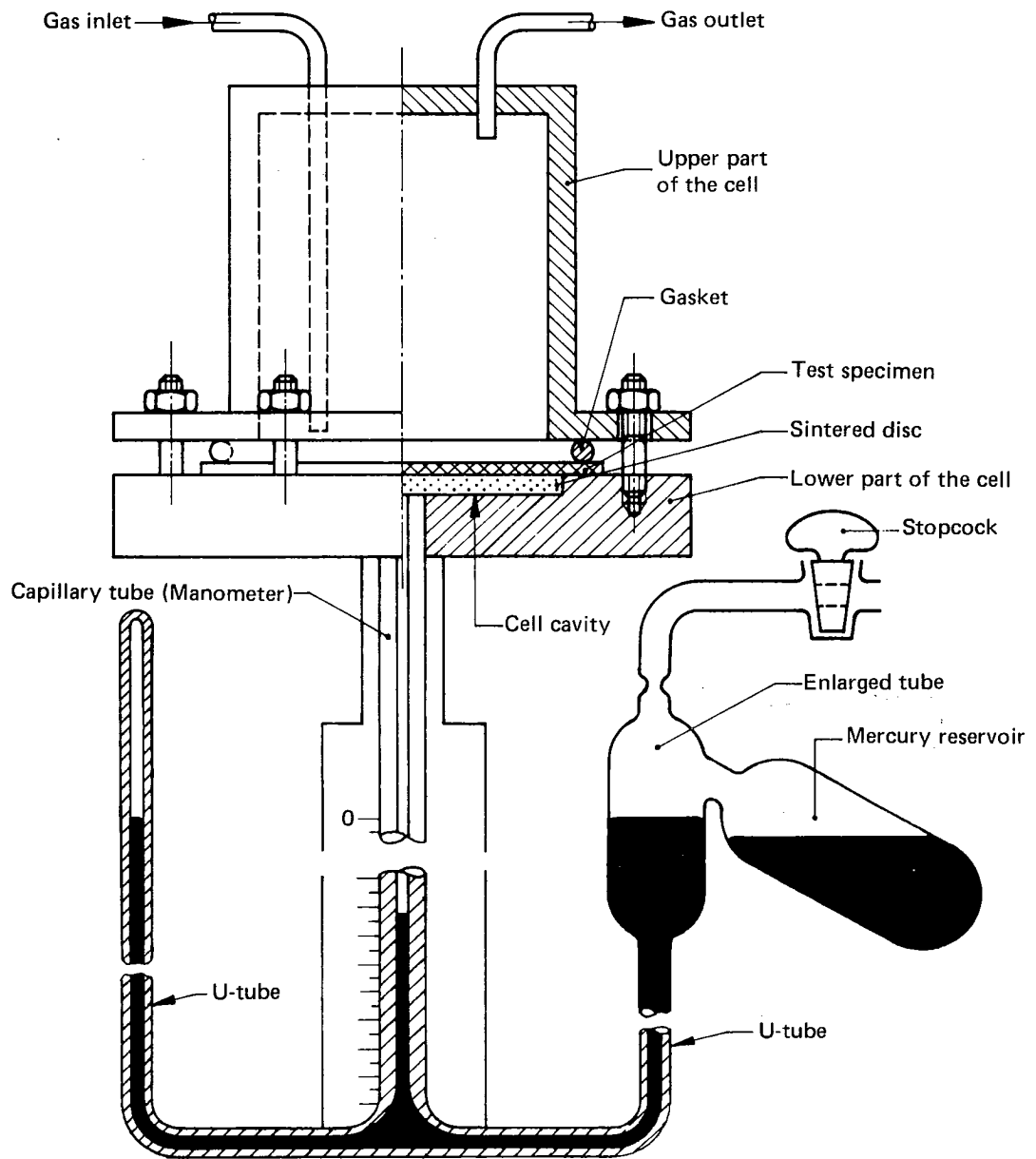

FIGURE 2 — Example of apparatus without overflowing (5.4, 2)