



INTERNATIONAL STANDARD ISO 2531:2009
TECHNICAL CORRIGENDUM 1

Published 2010-11-15

INTERNATIONAL ORGANIZATION FOR STANDARDIZATION • МЕЖДУНАРОДНАЯ ОРГАНИЗАЦИЯ ПО СТАНДАРТИЗАЦИИ • ORGANISATION INTERNATIONALE DE NORMALISATION

**Ductile iron pipes, fittings, accessories and their joints for
water applications**

TECHNICAL CORRIGENDUM 1

Tuyaux, raccords et accessoires en fonte ductile et leurs assemblages pour l'eau

RECTIFICATIF TECHNIQUE 1

Technical Corrigendum 1 to ISO 2531:2009 was prepared by Technical Committee ISO/TC 5, *Ferrous metal pipes and metallic fittings*, Subcommittee SC 2, *Cast iron pipes, fittings and their joints*.

Replace Table 6 with the following:

Table 6 — Permissible deviations on length of fittings

Dimensions in millimetres

Type of fitting	DN	Deviation
Flanged sockets Flanged spigots Collars, tapers	40 to 1200	±25
	1400 to 2600	±35
Tees	40 to 1200	+50 -25
	1400 to 2600	+75 -35
Bends 90° (1/4)	40 to 2600	±(15 + 0,03 DN)
Bends 45° (1/8)	40 to 2600	±(10 + 0,025 DN)
Bends 22° 30' (1/16) and 11° 15' (1/32)	40 to 1200	±(10 + 0,02 DN)
	1400 to 2600	±(10 + 0,025 DN)

Page 18, Table 11

Replace Table 11 with the following:

Table 11 — Dimensions of test bar

Type of casting	Test bar method A	Test bar method B		
	Nominal diameter mm	Nominal area S_0 mm ²	Nominal diameter mm	Tolerance on diameter mm
Centrifugally cast pipes with wall thickness:				
— less than 6 mm	2,5	5	2,52	±0,01
— 6 mm up to but not including 8 mm	3,5	10	3,57	±0,02
— 8 mm up to but not including 12 mm	5	20	5,05	±0,02
— 12 mm and over	6	30	6,18	±0,03
Pipes, fittings and accessories not centrifugally cast:				
— integrally cast samples	5	20	5,05	±0,02
— separately cast sample:				
— thickness 12,5 mm for casting thickness less than 12 mm	6	30	6,18	±0,03
— thickness 25 mm for casting thickness 12 mm and over	12 or 14	—	—	—

Page 21, Figure 1

Replace Figure 1 with the following (specifically, adding R and modifying the arrow for F):

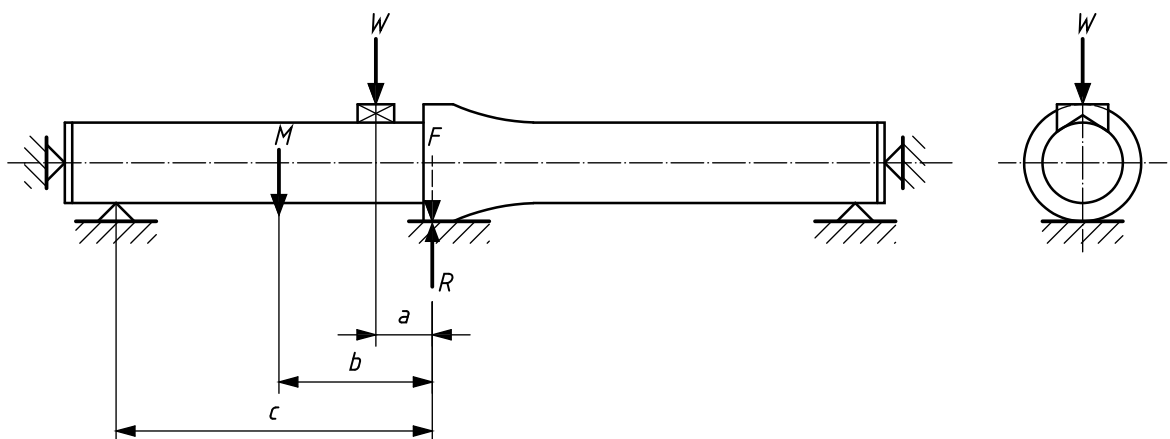

NOTE R is the reaction of the central support, expressed in newtons ($R = F$).

Figure 1 — Leaktightness of joints (internal pressure)

Replace Figure 16 with the following (specifically, replacing “ $\varnothing d$ ” with “ $\square d$ ”):

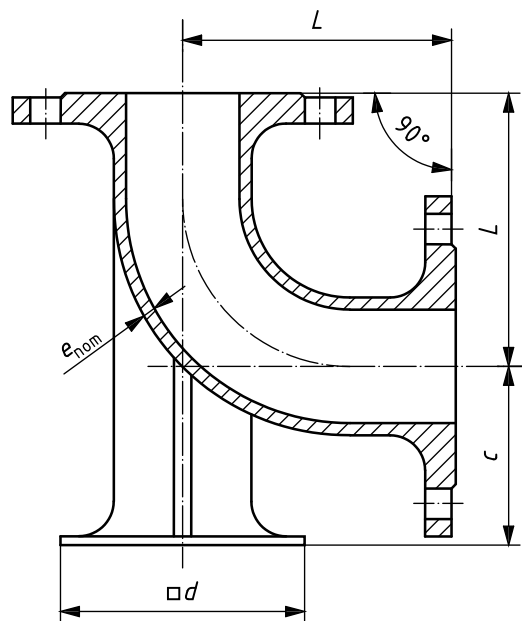

Figure 16 — Double-flanged duckfoot 90° bend