

INTERNATIONAL
STANDARD

ISO
2528

Second edition
1995-09-01

**Sheet materials — Determination of water
vapour transmission rate — Gravimetric
(dish) method**

*Produits en feuilles — Détermination du coefficient de transmission de la
vapeur d'eau — Méthode (de la capsule) par gravimétrie*



Reference number
ISO 2528:1995(E)

Foreword

ISO (the International Organization for Standardization) is a worldwide federation of national standards bodies (ISO member bodies). The work of preparing International Standards is normally carried out through ISO technical committees. Each member body interested in a subject for which a technical committee has been established has the right to be represented on that committee. International organizations, governmental and non-governmental, in liaison with ISO, also take part in the work. ISO collaborates closely with the International Electrotechnical Commission (IEC) on all matters of electrotechnical standardization.

Draft International Standards adopted by the technical committees are circulated to the member bodies for voting. Publication as an International Standard requires approval by at least 75 % of the member bodies casting a vote.

International Standard ISO 2528 was prepared by Technical Committee ISO/TC 6, *Paper, board and pulps*, Subcommittee SC 2, *Test methods and quality specifications for paper and board*.

This second edition cancels and replaces the first edition (ISO 2528:1974), which has been technically revised.

Annexes A and B form an integral part of this International Standard. Annex C is for information only.

© ISO 1995

All rights reserved. Unless otherwise specified, no part of this publication may be reproduced or utilized in any form or by any means, electronic or mechanical, including photocopying and microfilm, without permission in writing from the publisher.

International Organization for Standardization
Case Postale 56 • CH-1211 Genève 20 • Switzerland

Printed in Switzerland

Introduction

This International Standard describes a method which can in theory be applied to any sheet material. In practice its main use is for flat, usually thin, materials that can be processed to form a vapour-resistant barrier, as used in packaging, such as paper, board, plastics films or laminates of paper with films or metal foils, and for fabrics coated with rubber or plastics.

The water vapour pressure differential is the essential part of this test and in this instance it has not been possible to adopt the conditions recommended in ISO 554. In addition, the limits of temperature and humidity control are more exacting than those required for normal testing.

This test is intended to give reliable values of WVTR by means of simple apparatus. The use of the results of any particular application must, however, be based upon experience.

Transmission rate is not a linear function of temperature nor, generally, of relative humidity difference. A determination carried out under certain conditions is not, therefore, necessarily comparable with one carried out under other conditions. The conditions of test should, therefore, be chosen to be as close as possible to the conditions of use.

This page intentionally left blank

Sheet materials — Determination of water vapour transmission rate — Gravimetric (dish) method

1 Scope

This International Standard specifies a method for the determination of the water vapour transmission rate (often erroneously called "permeability") of sheet materials.

This method is not generally recommended for use if the transmission rate is expected to be less than 1 g/(m²·d) or for materials thicker than 3 mm. In such cases the method specified in ISO 9932 is preferred.

The method cannot be applied to film materials that are damaged by hot wax or that shrink to an appreciable extent under the test conditions used.

For some purposes it may be necessary to determine the transmission rate of creased material; a procedure for this is given in annex A.

2 Normative references

The following standards contain provisions which, through reference in this text, constitute provisions of this International Standard. At the time of publication, the editions indicated were valid. All standards are subject to revision, and parties to agreements based on this International Standard are encouraged to investigate the possibility of applying the most recent editions of the standards indicated below. Members of IEC and ISO maintain registers of currently valid International Standards.

ISO 186:1994, *Paper and board — Sampling to determine average quality*.

ISO 187:1990, *Paper, board and pulps — Standard atmosphere for conditioning and testing and procedure for monitoring the atmosphere and conditioning of samples*.

ISO 209-1:1989, *Wrought aluminium and aluminium alloys — Chemical composition and forms of products — Part 1: Chemical composition*.

ISO 291:1977, *Plastics — Standard atmospheres for conditioning and testing*.

ISO 471:1995, *Rubber — Temperatures, humidities and times for conditioning and testing*.

ISO 2231:1989, *Rubber- or plastics-coated fabrics — Standard atmospheres for conditioning and testing*.

ISO 2233:1994, *Packaging — Complete, filled transport packages — Conditioning for testing*.

ISO 9932:1990, *Paper and board — Determination of water vapour transmission rate of sheet materials — Dynamic sweep and static gas methods*.

3 Definition

For the purposes of this International Standard, the following definition applies.

3.1 water vapour transmission rate (WVTR): Mass of water vapour transmitted through a unit area in a unit time under specified conditions of temperature and humidity.

It is expressed in grams per square metre per 24 h [g/(m²·d)].

NOTE 1 The WVTR depends upon the thickness, composition and permeability of the constituent material or materials and upon the conditions of temperature and relative humidity under which the test is carried out (see annex B).

4 Principle

Dishes containing a desiccant and closed by the ma-

material to be tested are placed in a controlled atmosphere (see annex B).

These dishes are weighed at suitable intervals of time and the WVTR is determined from the increase in mass when this increase has become proportional to the time interval.

5 Apparatus and material

Figure 1 shows examples of equipment which has proved satisfactory in use, but other equipment may be equally satisfactory.

5.1 Test dishes, shallow, of glass, aluminium or stainless steel and of as large a diameter as can be accommodated on the balance to be used. The dishes should be light, but rigid and resistant to corrosion under the test conditions. Dishes made from aluminium, grade Al 99,5 as specified in ISO 209-1 and protected by chemical or anodic oxidation have been found suitable.

Each dish has a groove around the rim for sealing the test piece with wax. This groove has a profile such that the test piece can be sealed over the opening of the dish and no water vapour can escape at or through the edges of the test piece.

The internal diameter of the dish shall be equal to or very slightly larger than the diameter of the waxing templates (5.3).

The internal depth of the dish below the plane of the test piece should be not less than 15 mm (deep dish) or 8 mm (shallow dish) and there shall be no obstruction within the dish that might interfere with the flow of water vapour between the test piece and the desiccant.

The surface area of the bottom of the dish where it is filled with desiccant shall be similar to that of the exposed surface of the test piece.

Each dish shall be assigned a different number.

5.2 Lids, each numbered to correspond with a dish and made from the same material as the dish, with an outer rim designed to fit neatly over the outside of the dish so that there is negligible loss of water vapour when the dishes are removed from the test atmosphere for weighing.

5.3 Waxing templates, to place the wax sealant easily and to allow the test area to be defined exactly.

Their diameter, D , should preferably be $79,8 \text{ mm} \pm 0,4 \text{ mm}$ (an area of 50 cm^2).

If any other diameter of template is used, this fact shall be mentioned in the test report. In no case shall the diameter be less than 56,1 mm, and shall be known to an accuracy better than 1 %.

These templates may be either:

a) **cross-braced ring templates**, which remain in place during the test. Their diameter, D , is the internal diameter of the ring. As many ring templates as dishes are required;

or

b) **cover templates**, which must be taken off when the applied wax has cooled, comprising a disc with a central handle, drilled with a small hole at a suitable point (see figure 1), and having the edge chamfered at an angle of approximately 45° . Their diameter, D , is the diameter of this smaller circle.

Small guides can be fixed to the template to centre it automatically. A few templates are sufficient.

5.4 Sealant, a wax mixture (see annex C) which adheres strongly to both the dish and the test piece and is not brittle at ordinary temperature, not hygroscopic and not susceptible to oxidation. A surface of 50 cm^2 of freshly melted wax when exposed for 24 h in condition B (see annex B) shall not change in mass by more than 1 mg.

5.5 Water bath, for melting the wax.

5.6 Device for distributing the wax, of at least 25 ml capacity and a rapid rate of discharge, such as a pipette with a discharge tube of about 3 mm i.d. or a metal pourer with an insulated handle.

5.7 Cutting template or test-piece cutter, of a size suitable for cutting circular test pieces of a diameter suitable for the dishes in use (see figure 1). This diameter is slightly less than the inside diameter of the top of the dish (see figure 2).

5.8 Desiccant, silica gel or anhydrous calcium chloride (CaCl_2), in the form of granules 1,6 mm to 4 mm in size or alternatively in the form of a friable flaked product 1,5 mm to 2,0 mm in size.

NOTE 2 The limiting saturation of 1 g of calcium chloride is 0,1 g of water. The limiting saturation of 1 g of silica gel is 0,04 g of water.

5.9 Balance, for determining the mass of each dish, lid and contents to 0,1 mg.

Dimensions in millimetres

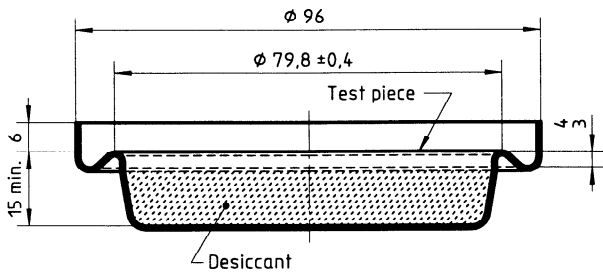

Deep dish (5.1) for materials with transmission rate greater than 100 g/(m²·d), (tapered to nest)

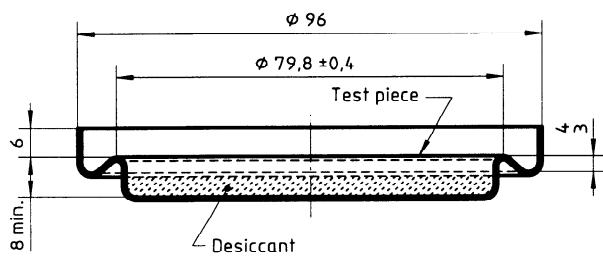

Shallow dish (5.1) for materials with normal transmission rate

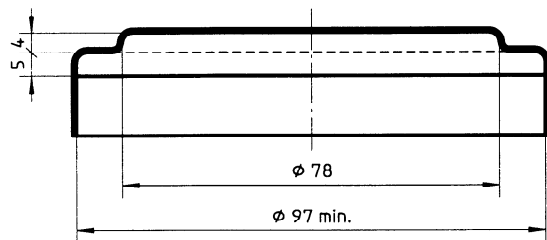

Lid (5.2) with rim to fit outside dish

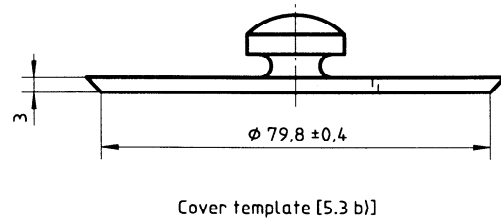

Cover template [5.3 b)]

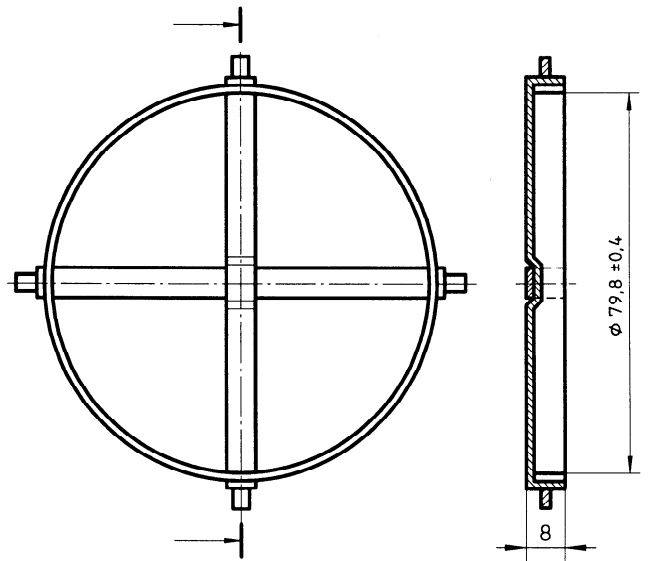

Ring template [5.3 a)]

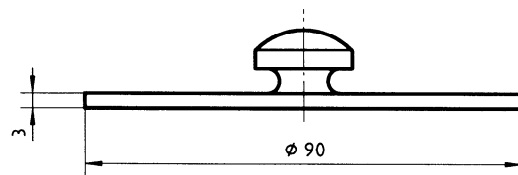

Cutting template (5.7)

NOTES

- Dimensions are shown for test areas of 50 cm². Values for dishes and lids show inside dimensions, except the overall diameter of the dishes, which is an outside dimension.
- Only the dimension 79,8 mm ± 0,4 mm shall be strictly respected; the other dimensions are approximate.

Figure 1 — Examples of test dishes and templates

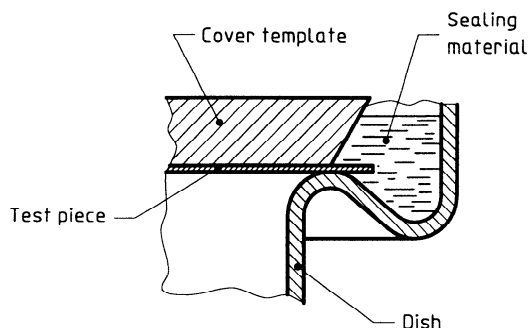

Figure 2 — Detail of sealing of test piece

5.10 Tongs, holders or other means of manipulating the dishes.

5.11 Enclosure, in which the required controlled atmosphere can be set (see annex B) and with air continuously circulated. The control shall be such that the specified conditions are re-established not more than 15 min after the door of the enclosure has been closed.

6 Sampling

If a lot of paper is to be evaluated, select samples in accordance with ISO 186.

7 Conditioning

It is recommended that samples be conditioned in accordance with ISO 187, ISO 291, ISO 471 or ISO 2231 depending on the material, prior to preparation of the test pieces, especially if the WVTR is known to be high.

8 Preparation of test pieces

Avoiding all damaged areas, cut from the sample, with the aid of the cutting template or test piece cutter (5.7), at least three circular test pieces of the appropriate diameter, normally 90 mm (see figure 1), for each face to be tested. Mark the test pieces in some way so that the side to be exposed to the test atmosphere can be readily identified.

If the material is hygroscopic or if a greater accuracy is required (see 10.2), prepare at least two blank test pieces.

NOTE 3 If the sheet material has been prepared by a process involving solvents, the results may be affected by

the residual solvent in the test pieces. If the test pieces are treated to remove the residual solvent, details of this treatment should be included in the test report.

9 Preparation of dishes

The method of preparation of the dishes differs slightly according to whether a cover or ring template is used.

Always begin by carefully cleaning and drying the dishes and the templates.

Introduce the desiccant (5.8) into the dish (5.1), then put the test piece (clause 8) on the dish with the required face upwards and then the waxing template (5.3), and make a vapour-tight wax seal between the test piece and the dish. Details for the different types of template are given in 9.1 and 9.2. The work must be done rapidly in order to keep the absorption of water vapour by the desiccant to a minimum.

WARNING — Care should be taken when handling hot wax, as serious burns could occur if the wax is spilled or splashed. Suitable protective equipment such as glasses, gloves, etc. should be worn.

9.1 Use of wax and a cover template [5.3 b)]

Fill each dish with desiccant up to 3 mm to 4 mm below the final position of the test piece and level by tapping.

Melt the wax (5.4) on the water bath (5.5) and fill the dispensing device (5.6).

Place the test piece (clause 8) centrally in position, followed by the waxing template. Run the molten wax into the groove until it reaches the level of the upper surface of the waxing template and, after cooling, complete the joint by removing air bubbles and hair cracks with a small gas flame. A warm spatula may be run over the wax to assist in this process, so that shrinkage cracks that may have developed during cooling will be closed.

Remove the waxing template and examine the assembly to make sure that the joint is satisfactory. To ensure that the waxing template comes away easily, it is advisable first to smear a thin film of petroleum jelly around the edge and to wipe away any excess which could contaminate the test piece.

Cover the assembly with a lid (5.2) numbered to correspond with the number of the dish.

9.2 Use of wax and a ring template [5.3 a)]

Fill each dish with desiccant up to a level of 3 mm to 4 mm below the final position of the test piece and level by tapping. Melt the wax (5.4) on the water bath (5.5) and fill the dispensing device (5.6). Run the molten wax into the circular groove round the dish until a slight meniscus is produced above the inner edge of the groove.

Place the test piece (clause 8) centrally in position on the dish, followed by the ring template, and load it with a 1 kg weight.

Run more wax into the annular space so formed and, after cooling, complete the joint by removing any air bubbles and hair cracks with a small gas flame. A warm spatula may be run over the wax to assist in this process, so that shrinkage cracks that may have developed during cooling will be closed. Remove the weight and leave the ring in place.

Cover the assembly with a lid (5.2) numbered to correspond with the number of the dish.

10 Procedure

10.1 General method

10.1.1 Weigh all the prepared dishes, with their lids, on the balance (5.9) to the nearest 0,1 mg.

10.1.2 Place them upright in the enclosure (5.11) controlled to the conditions of the test (see annex B), after removing the lids.

10.1.3 Carry out successive weighings of the dishes, with their lids, at suitable intervals of time.

The weighings shall be carried out as follows:

Cover the dishes with their respective lids and remove them from the controlled enclosure using the tongs or holders (5.10) and leave them for 15 min to reach ambient temperature. Weigh the assemblies to the nearest 0,1 mg, and return them to the enclosure after again taking off the lids.

Take care to work rapidly, taking the dishes in small groups always containing the same number, so that the whole weighing operation always lasts about the same time (not exceeding 30 min).

It is also possible to work without the lids, but in this case it is advisable to use blank assemblies (see 10.2), and transport and cooling of the dishes must be done in a closed vessel with calcium chloride desiccant.

The interval between weighings should preferably be 24 h, 48 h or 96 h, but shorter time intervals (for example 3 h, 4 h or 8 h) may be necessary for materials with a high transmission rate. The choice depends on the transmission rate of the sheet being tested; the gain in mass between two successive weighings should be at least 5 mg. The choice of time interval is to be made at the beginning of the test.

If the first weighing shows a gain in mass too large or too small, the subsequent time intervals for weighing may be modified.

10.1.4 Continue the weighings until the increase in mass of two successive weighings per unit time of exposure to the selected atmosphere becomes constant to within 5 %.

10.1.5 The test must be completed before the efficiency of the desiccant is appreciably reduced. (In practice, the total increase in mass should not exceed 1,2 g for shallow dishes and 3,2 g for deep ones.)

10.2 Use of blank assemblies

If the sample is of low transmission rate and considerable thickness, for example rubber, plastics or polyethylene-coated board, or is appreciably hygroscopic, it is advisable to test two or more blank assemblies, prepared in the same manner but without desiccant, in addition to the three normal test assemblies. All the measured masses are then corrected at each time interval by subtracting the mean change in mass of the blank assemblies which undergo the same treatment.

10.3 Creased sheet

Annex A gives a method for determining the WVTR of a creased sheet.

11 Expression of results

11.1 Express the test results by the method given in either 11.1.1 or 11.1.2.

11.1.1 For each dish, represent the total increase in mass graphically as a function of time of exposure, the test being completed when three or four points lie on a straight line (see 10.1.4), showing a constant rate of passage of water vapour.

Using this straight line, the WVTR for each test piece is then calculated, in grams per square metre per 24 h, from the formula

$$\frac{240 \times m_1}{S}$$

where

- m_1 is the rate of increase in mass, in milligrams per hour, determined from the graph;
- S is the area, known to within 1 %, in square centimetres (normally 50 cm²), of the tested surface of the test piece.

11.1.2 If weighings are made at identical time intervals, it is possible to calculate the transmission rate for each test piece directly from the results, without preparing a graph, by

using the formula in 11.1.1 but substituting m_2/t for m_1 :

$$\frac{240 \times m_2}{S \times t}$$

where

- t is the total duration, in hours, of the last two exposure periods (see 10.1.4);
- m_2 is the increase in mass, in milligrams, of the assembly during the time t .

11.2 For several assemblies corresponding to a single sample of test material and to a single face, calculate the arithmetic mean of the results obtained in accordance with either 11.1.1 or 11.1.2.

11.3 Report the mean WVTR by rounding

values over 100 g/(m²·d): to the nearest 10 g/(m²·d);

values from 10 g/(m²·d) to 100 g/(m²·d): to the nearest whole number;

values less than 10 g/(m²·d): to the first decimal place.

12 Precision

There is insufficient data available at this time to allow any statement to be made regarding repeatability and reproducibility.

13 Test report

The test report shall include the following information:

- a) a reference to this International Standard;
- b) all details necessary for complete identification of the material tested, in particular grammage, thickness (if required) and identification of the outside face during tests;
- c) the depth of the dish;
- d) the test conditions (see annex B);
- e) the type of desiccant used;
- f) the arithmetic mean, if the largest difference between individual WVTR results and the arithmetic mean does not exceed 10 % of this mean; otherwise report the individual WVTR results obtained (see clause 11);
- g) whether the test has been carried out on creased test pieces in accordance with annex A;
- h) any other information which may help in interpretation of results, for example a treatment to remove residual solvent.

Annex A (normative)

Method for determination of water vapour transmission rate of creased materials

A.1 General

If the WVTR of creased material is required, the creasing should be carried out using one of the procedures recommended in this annex.

A.2 Definitions

For the purposes of this annex to ISO 2528, the following definitions apply.

A.2.1 transmission rate of creased sheet: Rate of transmission, expressed in grams per square metre per 24 h, measured on a test piece cut after the sheet has been creased in a standardized manner and after the sheet has been restored to the flat condition.

A.2.2 transmission rate of creases: Difference between the transmission rate of the creased sheet and the transmission rate of the uncreased sheet, both given in grams per square metre per 24 h; it is expressed in grams per 100 linear metres (of creases) per 24 h [g/(100 m·d)].

A.3 Principle

A test piece is cut and creased to give a double series of creases in concertina fashion forming a pattern of squares, with creases at right angles.

The spacing of the pattern of squares is such that, in the final test piece, the value of the total length of the creases, in centimetres, located within the area S is the same number as the area, in square centimetres; for example, the total length of the creases is 50 cm when the test area is 50 cm².

The test piece is cut and put into the dish in such a manner that the centre of the circular dish is at the centre of one of the squares formed by the creases.

A.4 Apparatus

A.4.1 Creasing table, in the form of a flat rectangular plate, the width of which is slightly larger than the larger dimension of the test piece.

A.4.2 Cutting template, of square shape having the dimensions of the test piece before creasing. This template may have notches making it possible to mark the position of the creases (see figure A.1).

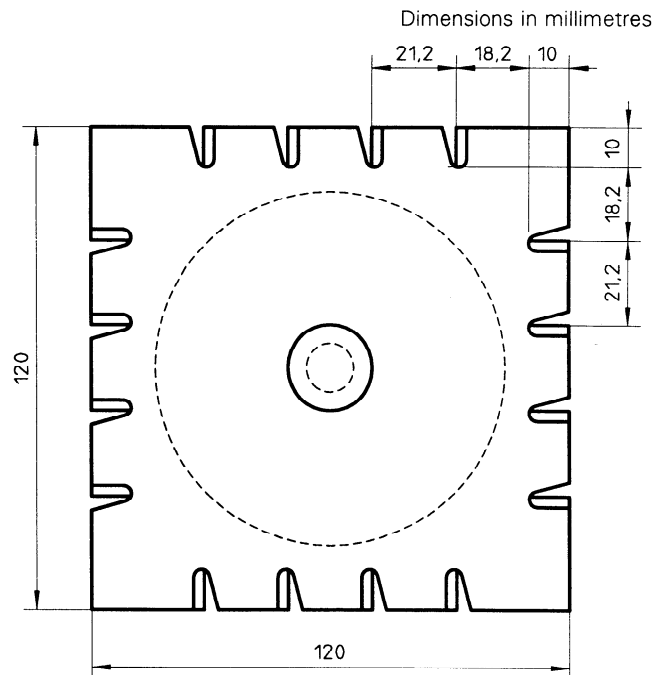

Dimensions shown will produce a test area of 50 cm²

Figure A.1 — Example of cutting template (A.4.2)

A.4.3 Pressing plate, rigid rectangular flat plate, of length about 175 mm and width either 15 mm (Procedure A) or 30 mm (Procedure B), capable of being loaded so that a load of 9,8 N per 10 mm of crease length is applied.

The creasing may also be carried out using a suitable press.

A.4.4 Ruling plate (or wooden rule), approximately 200 mm × 30 mm, with smooth straight edges.

A.5 Preparation of test pieces for creasing

The number of test pieces to be prepared for creasing is the same as that specified in clause 8 of this International Standard.

Using the template (A.4.2), cut the test pieces in a square shape of dimensions 120 mm × 120 mm if procedure A is to be applied or 170 mm × 170 mm if procedure B is to be applied.

If a sheet with a particular direction (for example, machine direction) is used, the cutting shall be carried out in such a manner that this direction is parallel to one of the sides of the test piece (unless specified that the cutting is to be made diagonally, in which case there shall be an angle of 45° between the particular direction and the sides of the template).

If a template with notches is used, mark each crease (with a notch or pencil line, for example) on the periphery of the test piece for creasing.

A.6 Conditioning of the test pieces before creasing

Condition the test pieces in the conditions usual for the material, i.e. in accordance with the requirements of ISO 187, ISO 291, ISO 471 or ISO 2231.

In the absence of any particular recommendation, choose one of the above International Standards.

A.7 Creasing

A.7.1 Crease spacing and loading

The spacing of the square pattern (see A.3) depends on the actual area of test, S . (Each side of a square is 21,2 mm for the recommended area of 50 cm².)

The pressing of the creases is carried out by applying a load of 9,8 N per 10 linear millimetres of crease, on a single crease or on several creases at a time.

A.7.2 Folding to make the creases

The creases may be prepared in any manner; however, the following procedures are recommended.

A.7.2.1 Procedure A (120 mm × 120 mm test piece for a test area of 50 cm²). Make the first crease by folding the test piece at the outer pair of marks, lightly applying the ruling plate (A.4.4) to the sheet and letting it slide towards the crease.

Open the test piece and make the second, then third and fourth creases.

Take care to crease the test piece so that each two adjacent folds open in opposite directions (in such a manner as to form a "concertina").

Make the second series of creases by carrying out exactly the same operation, but in a direction perpendicular to the first.

A.7.2.2 Procedure B (170 mm × 170 mm test piece for a test area of 50 cm²). Make a "concertina" of eight equal rectangles in the following manner:

- a) make a centre crease by bringing together two opposite edges of the test piece, and make the crease by placing the sheet on the creasing table (A.4.1) and lightly applying the ruling plate (A.4.4) close to the edges which meet and sliding it towards the crease;
- b) open the test piece, then form and make the crease of a quarter of the test piece by bringing one of the edges of the test piece to coincide with the centre crease already made;
- c) make the same crease for the opposite quarter, these two creases and the centre crease having their concavity on the same side of the sheet (see figure A.2);
- d) open the sheet and turn the upper side of the test piece downwards;
- e) form and make the other four creases of the "concertina" by successively placing one edge of the test piece to coincide with the crease of the first quarter, the crease of the first quarter with the middle crease, the middle crease with the crease of the third quarter and the crease of the third with the other edge of the test piece (see figure A.2).

Make the second series of creases by carrying out exactly the same operation, but in a direction perpendicular to the first.

A.7.3 Pressing the creases

The creases can be pressed crease by crease, or all of the creases can be pressed simultaneously.

In either case, place the creased test piece on the creasing table, and press it for about 30 s by covering the crease or creases systematically with the pressing plate suitably loaded to press the creases with a load of 9,8 N per 10 mm of crease.

A.8 Preparation of creased test pieces for test

Flatten the creased test pieces and, using the cutting template (6.8) or other suitable means, cut from each test piece a circular test piece whose centre is at the centre of the centre square (formed with Procedure A) or a square adjacent to the centre (Procedure B) of the creased test piece.

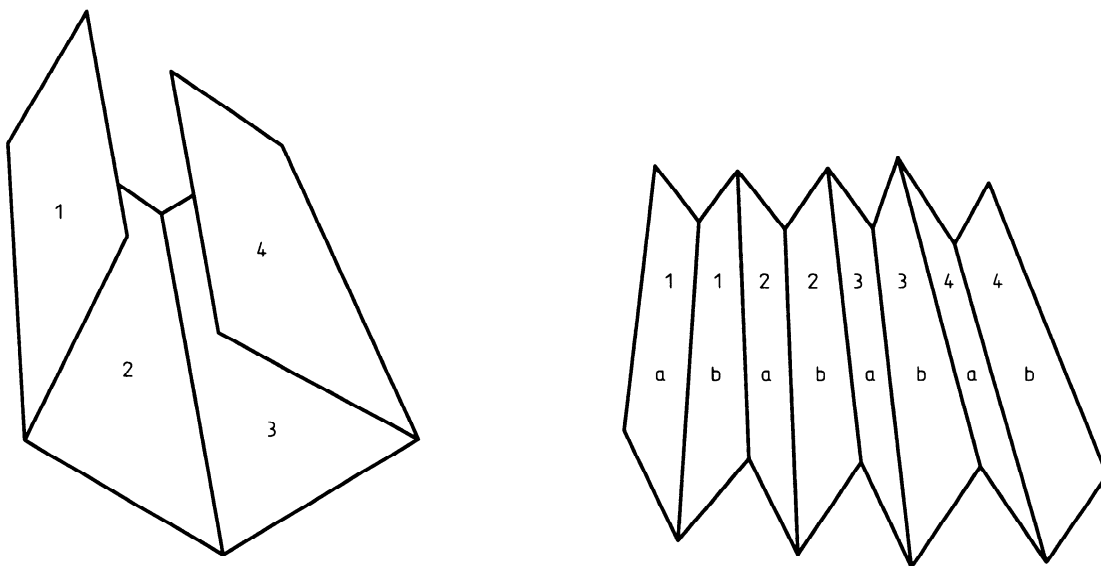

Figure A.2 — Making the creases (Procedure B, A.7.2.2)

A.9 Determination of water vapour transmission rate

Carry out the determination of the water vapour transmission rate using the method given in clause 10, on both the uncreased and creased test pieces.

A.10 Expression of results

Taking the two mean values obtained (on the uncreased test pieces and on the creased test pieces) expressed in grams per square metre per 24 h, calculate the difference, in grams per 100 m per 24 h, which is called transmission rate of the creases.

Express the results by giving

- the transmission rate of the uncreased test pieces and that of the creased test piece, in grams per square metre per 24 h [$\text{g}/(\text{m}^2 \cdot \text{d})$];
- the transmission rate of the creases, in grams per 100 m per 24 h [$\text{g}/(100 \text{ m} \cdot \text{d})$].

Annex B (normative)

Test conditions

Although other atmospheric conditions may be required for special test purposes, certain standard temperatures and relative humidities have been established for testing paper and plastics. These are:

Condition A

Temperature $25\text{ °C} \pm 1\text{ °C}$

Relative humidity $(90 \pm 2)\%$

Condition B

Temperature $38\text{ °C} \pm 1\text{ °C}$

Relative humidity $(90 \pm 2)\%$

Condition C

Temperature $25\text{ °C} \pm 1\text{ °C}$

Relative humidity $(75 \pm 2)\%$

Condition D

Temperature $23\text{ °C} \pm 1\text{ °C}$

Relative humidity $(85 \pm 2)\%$

Condition E

Temperature $20\text{ °C} \pm 1\text{ °C}$

Relative humidity $(85 \pm 2)\%$

Conditions A and B can be achieved by the use of a saturated solution of potassium nitrate.

Condition C can be achieved by use of a saturated solution of sodium chloride.

Conditions D and E can be achieved by use of a saturated solution of potassium chloride.

NOTE 4 Relative humidity sensors are affected by salt mist, thus precautions should be taken to protect the sensor from the mist.

The relative humidity (R.H.) requirements are deemed to have been achieved if the reading, corrected for systematic error, provided by a calibrated relative humidity sensor remains within the specified range. A calibrated relative humidity sensor is any sensor which is certified to operate with a random error of not more than 1 % R.H, a systematic error (departure from true humidity) of not more than 2 % R.H. and a response rate which enables the sensor to track a gradient of 1,5 % R.H. per minute.

NOTE 5 For investigation into the WVTR of packaging materials under conditions likely to be experienced during transport or storage, it is recommended that the appropriate conditions be selected from those given in ISO 2233.

Annex C (informative)

Sealing waxes

Suitable wax compositions for use as sealants (see clause 9) are:

- a) 60 % microcrystalline wax and 40 % refined crystalline paraffin wax.
- b) 90 % microcrystalline wax and 10 % plasticizer¹⁾.
- c) 80 % paraffin wax and 20 % viscous polyisobutylene (relatively low degree of polymerization).

- d) Mixture of waxes with oil content 1,5 % to 3 %.

All combinations of material should have melting points within the range 50 °C to 75 °C.

If the wax contains traces of water, they can be eliminated by heating to 105 °C to 110 °C and stirring.

The oil content of the microcrystalline wax should be below 3 %, and that of the refined paraffin wax below 1 %.

1) Mobil Oil Co. Ltd. microcrystalline wax Mobilwax 2305 with Mobil-Kote 338 as plasticizer has been found suitable.

This information is given for the convenience of users of this International Standard and does not constitute an endorsement by ISO of the products named. Equivalent products may be used if they can be shown to lead to the same results.

ICS 85.060

Descriptors: paper, paperboards, sheets, plastic sheets, fabrics coated with rubber, fabrics coated with plastics, tests, determination, vapour transmission, water vapour.

Price based on 11 pages
